

REVISIONS

P	LTR	DESCRIPTION	DATE	DWN	APVD
6	ECR-21-113847		15SEP2021	E.Z	N.S

NOTES:

- MATERIAL:
  - HOUSING: HIGH TEMPERATURE THERMOPLASTIC UL94V-0, COLOR: NATURAL. AND COLOR BLACK IS FOR 8-2328702-8 AND 9-2328702-8.
  - ACTUATOR: HIGH TEMPERATURE THERMOPLASTIC UL94V-0, COLOR: BLACK. AND COLOR NATURAL IS FOR 8-2328702-8, COLOR BLUE IS FOR 9-2328702-8.
  - CONTACT: COPPER ALLOY.
  - FITTING NAIL: STAINLESS STEEL.
- FINISH:
  - CONTACT: GOLD FLASH ON CONTACT AREA. AND SOLDER TAILS. 50u"MIN. NICKEL UNDERPLATING OVERALL.
  - FITTING NAIL: TIN PLATING ON SOLDER TAILS. 50u" MIN. NICKEL UNDERPLATING OVERALL.
- SPECIFICATION:
 

VOLTAGE: 50V AC/DC  
 CURRENT RATING: 0.5 AMPERE  
 CONTACT RESISTANCE: INITIAL 50 mOHMS MAX. AFTER TEST Δ30 mOHMS MAX.  
 DIELECTRIC WITHSTANGDING VOLTAGE: 250V AC/1 MINUTE;  
 INSULATION RESISTANCE: 500M OHMS MIN.  
 FFC/FPC WITHDRAWL FORCE: 0.20N PER CONTACT MIN;  
 FFC/FPC THICKNESS: 0.30+/-0.03mm.
- THE PRODUCT IS RoHS AND HF COMPLIANT.

△ PIN NO.

PRELIMINARY PART NO.	8	5.10	4.53	3.50	5.38	6.00	9-2328702-8
	8	5.10	4.53	3.50	5.38	6.00	8-2328702-8
	30	16.10	15.53	14.50	16.38	17.00	3-2328702-0
	24	13.10	12.53	11.50	13.38	14.00	2-2328702-4
	16	9.10	8.53	7.50	9.38	10.00	1-2328702-6
	10	6.10	5.53	4.50	6.38	7.00	1-2328702-0
	8	5.10	4.53	3.50	5.38	6.00	2328702-8
	6	4.10	3.53	2.50	4.38	5.00	2328702-6
	4	3.10	2.53	1.50	3.38	4.00	2328702-4
PIN NO.	DIM.E	DIM.D	DIM.C	DIM.B	DIM.A		PART NO.

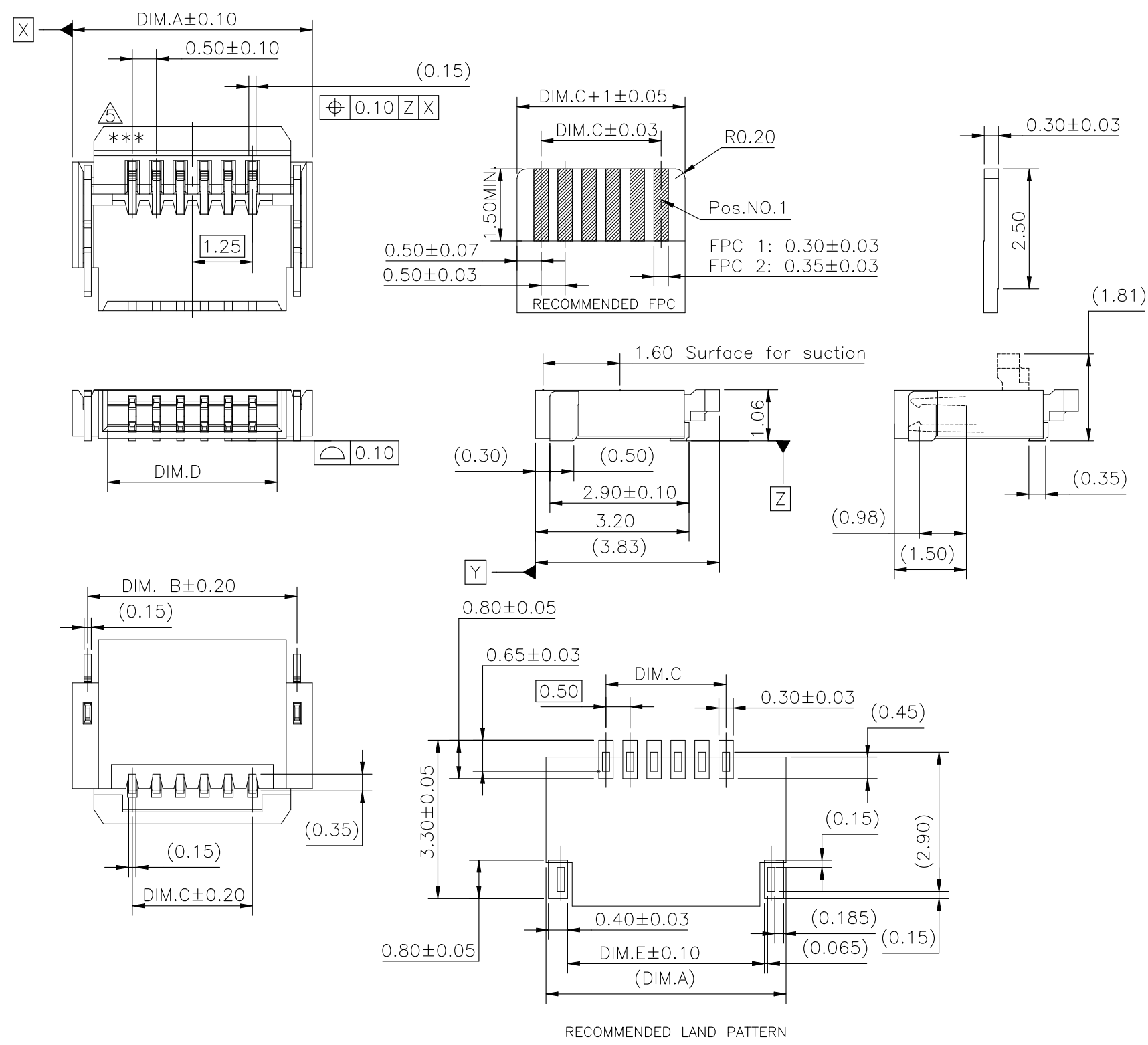

THIS DRAWING IS A CONTROLLED DOCUMENT.		DWN ELIANA ZHANG 20171228
DIMENSIONS: mm		CHK WENKE HE 20171228
TOLERANCES UNLESS OTHERWISE SPECIFIED:		APVD WENKE HE 20171228
0 PLC	± 0.40	NAME 0.5 PITCH FPC CONNECTOR BACK FLIP
1 PLC	± 0.25	
2 PLC	± 0.15	
3 PLC	± 0.10	
4 PLC	± -	
ANGLES	± -	PRODUCT SPEC 108-115142
MATERIAL	FINISH	APPLICATION SPEC
-	-	SIZE A3

DWN ELIANA ZHANG 20171228		TE Connectivity Ltd.	
CHK WENKE HE 20171228		NAME 0.5 PITCH FPC CONNECTOR BACK FLIP	
APVD WENKE HE 20171228		PRODUCT SPEC 108-115142	
APPLICATION SPEC		SIZE A3	CAGE CODE 00779
WEIGHT SEE TABLE		DRAWING NO C-2328702	RESTRICTED TO -
CUSTOMER DRAWING		SCALE 1:1	SHEET 1 OF 2
		REV 6	

P	LTR	DESCRIPTION	DATE	DWN	APVD
-	-	SEE SHEET 1	-	-	-

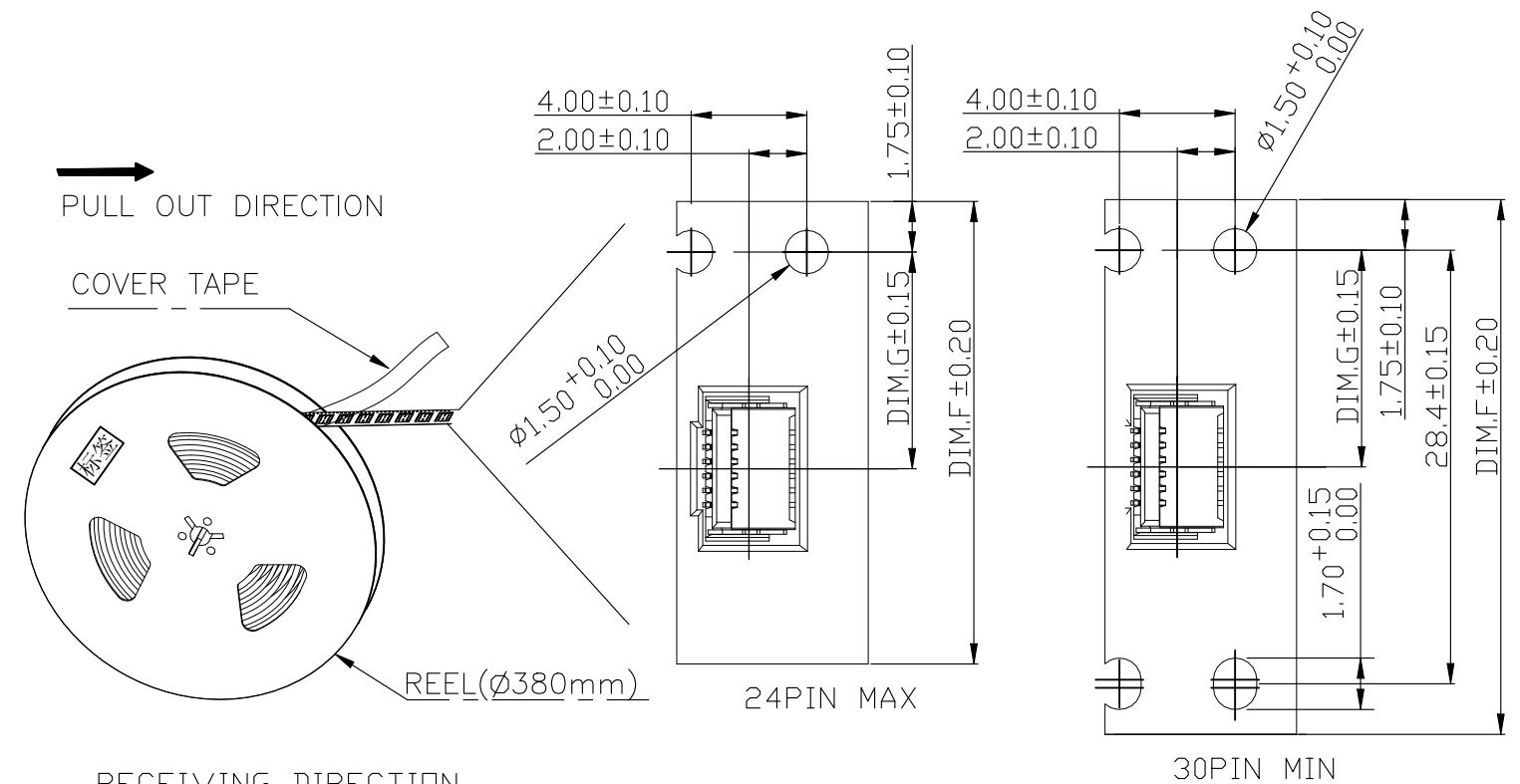

- NOTES: (APPLIED TO CURRENT SHEET)
1. THE DIRECTION OF EACH CONNECTOR ON A EMBOSS IS REFERRED TO THIS DRAWING.
  2. PACKAGED IN EMBOSS TAPE AND PLASTIC RELL 4000 PCS PER RELL.
  3. WINDING THE COVER TAPE AROUND THE OUTER PERIPHERY IN A TURN.

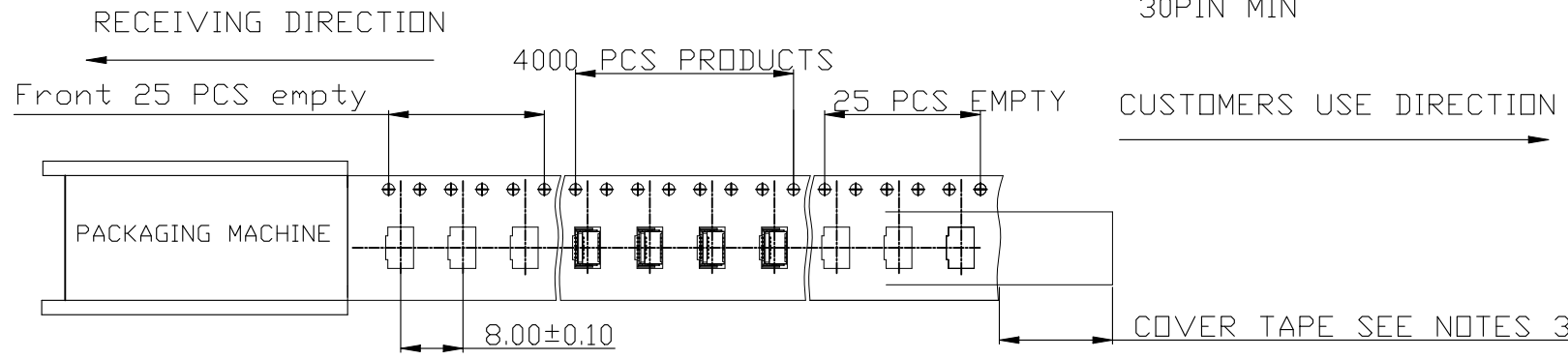

TABLE A

P/N	PIN NO.	Amount of packing			Weight of packing			DIM F	DIM G
		Pcs/ Reel	Reel/ Carton	PCS/ Carton	Unit weight (g)	Net weight (kg)	GW (kg)		
3-2328702-0	30	4,000	4	16,000	0.0848	1.357	5.421	32.00	14.20
2-2328702-4	24	4,000	5	20,000	0.0827	1.654	5.735	24.00	11.50
1-2328702-6	16	4,000	5	20,000	0.0615	1.230	5.311	16.00	7.50
1-2328702-0	10	4,000	7	28,000	0.0405	1.134	5.275		
2328702-8	8	4,000	7	28,000	0.0335	0.938	5.06		
8-2328702-8	8	4,000	7	28,000	0.0335	0.938	5.06		
9-2328702-8	8	4,000	7	28,000	0.0335	0.938	5.06		
2328702-6	6	4,000	7	28,000	0.0280	0.611	4.845		
2328702-4	4	4,000	7	28,000	0.0218	1.654	4.675		



THIS DRAWING IS A CONTROLLED DOCUMENT.

DIMENSIONS: mm	TOLERANCES UNLESS OTHERWISE SPECIFIED:	DWN ELIANA ZHANG 28DEC2017	<b>STE</b> TE Connectivity Ltd.			
0 PLC ± 0.40	1 PLC ± 0.25	CHK WENKE HE 20171228				
2 PLC ± 0.15	3 PLC ± 0.10	APVD WENKE HE 20171228	NAME			
4 PLC ± -	ANGLES ± -	PRODUCT SPEC 108-115142	0.5 PITCH FPC CONNECTOR BACK FLIP			
MATERIAL	FINISH	APPLICATION SPEC	SIZE	CAGE CODE	DRAWING NO	RESTRICTED TO
-	-	-	WEIGHT SEE TABLE	A3	00779	C-2328702
CUSTOMER DRAWING			SCALE 1:1	SHEET 2 OF 2	REV 6	

单击下面可查看定价，库存，交付和生命周期等信息

[>>TE Connectivity\(泰科\)](#)