

THIS DRAWING IS UNPUBLISHED. RELEASED FOR PUBLICATION  
 © COPYRIGHT BY TYCO ELECTRONICS CORPORATION. ALL RIGHTS RESERVED.

LOC	DIST	REVISIONS			
P	LTR	DESCRIPTION	DATE	DWN	APVD
AG	53	0	RELEASED.	30SEP2005	JGH/JGH

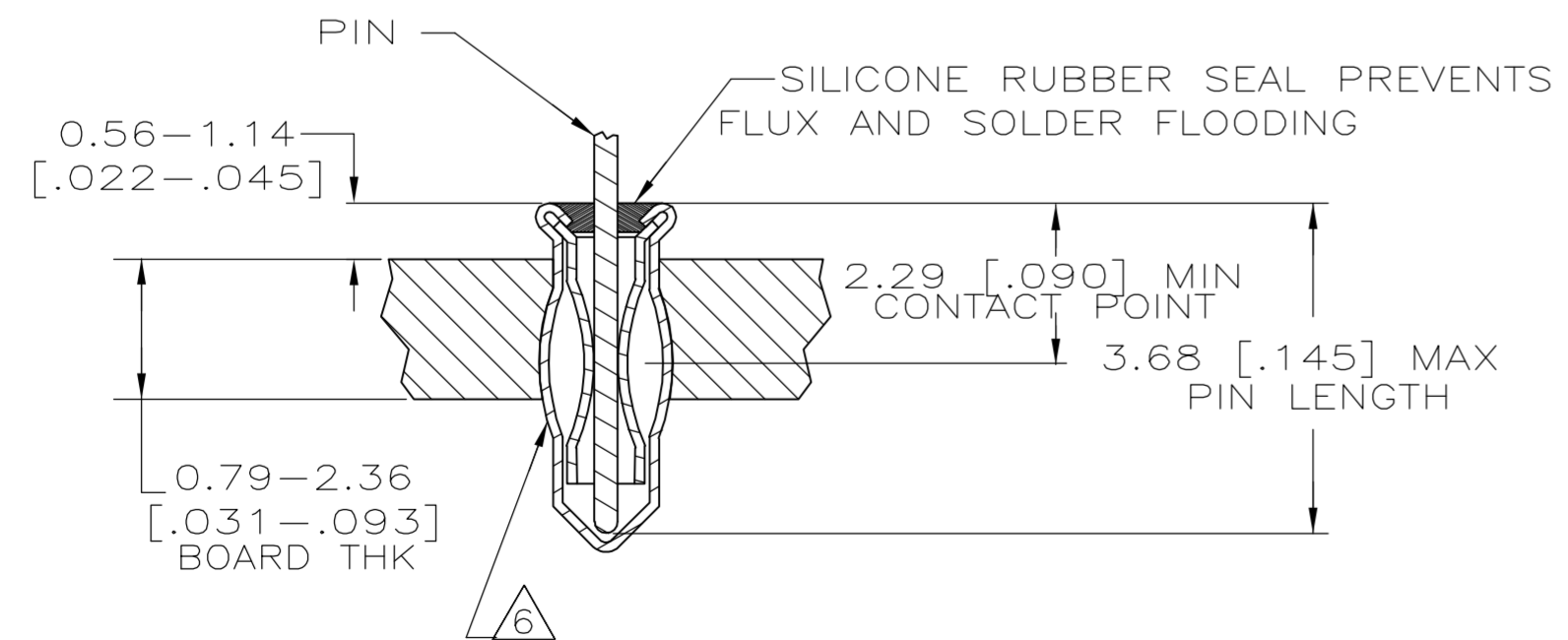
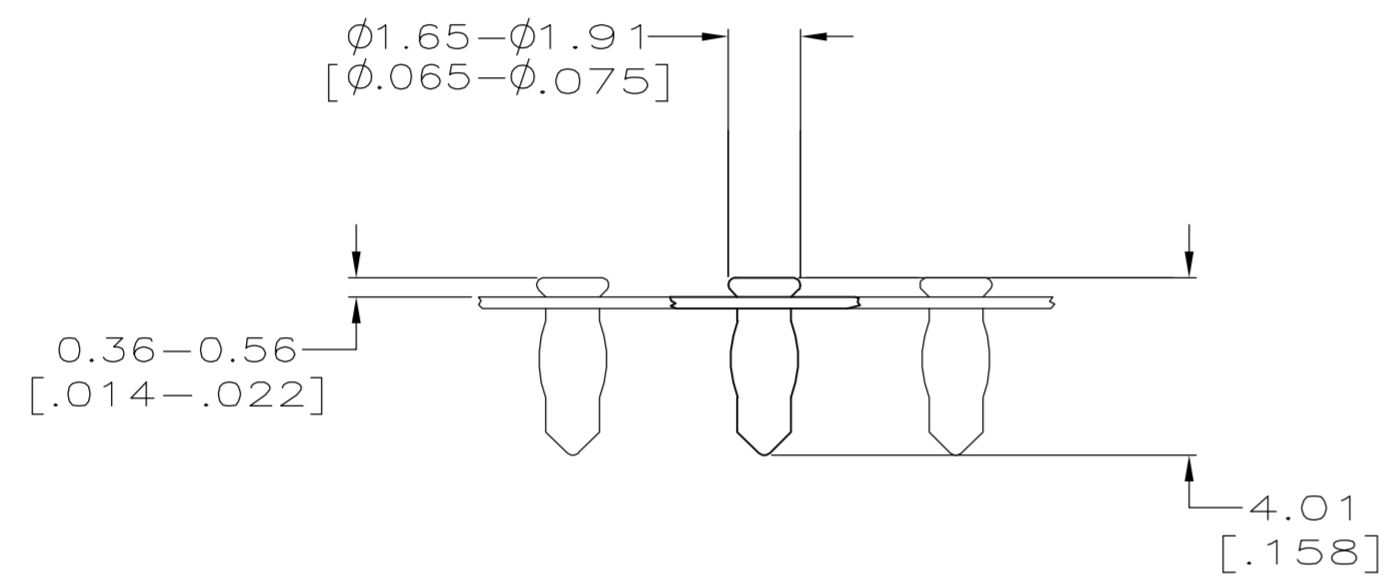
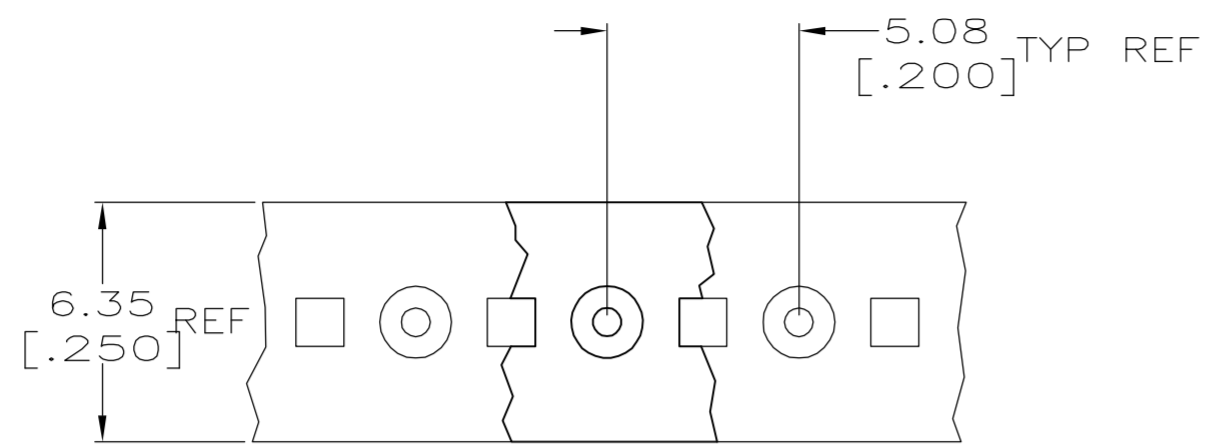

- 1 MATERIAL:  
 EYELET - COPPER PER ASTM B 152  
 SPRING - BERYLLIUM COPPER PER ASTM B 194  
 SEALANT - SILICONE RUBBER
- 2 TIN PLATE PER ASTM B 545 0.00381 [.000150] MIN THICK.
- 3 GOLD PLATE PER ASTM B 488 0.00076 [.000030] MIN THICK ON CONTACT AREA.
- 4 PACKAGED 50,000 PER REEL.
- 5 TO INSURE 1/2 OZ MIN RETENTION DO NOT EXCEED 0.10 [.004] DIFFERENCE IN PIN DIA WHEN CHANGING TO A SMALLER DIA PIN
- 6 PRODUCT IS OVALIZED FOR RETENTION IN THE P.C. BOARD. THE RECOMMENDED HOLE DIAMETER IS  $\phi 1.32$  [ $\phi 0.052$ ] MINIMUM, +0.08 [.003] MAX. PRIOR TO SOLDERING.
- 7 PACKAGED 10,000 PER REEL.

2.29-3.68 [.090-.145]	$\phi 0.36-0.56$ [ $\phi 0.014-.022$ ]			7 1-5645953-5
	$\phi 0.51-0.66$ [ $\phi 0.020-.026$ ]	GOLD 3	TIN 2	7 1-5645953-2
				4 5645953-2
LENGTH	DIAMETER 5	SPRING	EYELET	PART NUMBER
PIN		FINISH		
THIS DRAWING IS A CONTROLLED DOCUMENT.		DWN J. HAVENER 30SEP2005	tyco Tyco Electronics Corporation Harrisburg, PA 17105-3608	
DIMENSIONS: INCHES		CHK J. HAVENER 30SEP2005	NAME	
TOLERANCES UNLESS OTHERWISE SPECIFIED:		APVD J. HAVENER 30SEP2005	PRODUCT SPEC	
0 PLC ± -		108-14008		
1 PLC ± -		APPLICATION SPEC		
2 PLC ± -		114-26004		
3 PLC ± 0.20 [.008]		SIZE A2	CAGE CODE 00779	DRAWING NO C=5645953
4 PLC ± -		WEIGHT -	SCALE NTS	SHEET 1 of 1
ANGLES ± -		CUSTOMER DRAWING		
FINISH SEE TABLE		REV 0		

645953  
5645953

单击下面可查看定价，库存，交付和生命周期等信息

[>>TE Connectivity\(泰科\)](#)