

THIS DRAWING IS UNPUBLISHED. RELEASED FOR PUBLICATION  
 © COPYRIGHT BY TYCO ELECTRONICS CORPORATION. ALL RIGHTS RESERVED.

LOC	DIST	REVISIONS					
G	14	P	LTR	DESCRIPTION	DATE	DWN	APVD
			F	REV PER ECR 07-002624 & 002751	10APR07	JR	TM

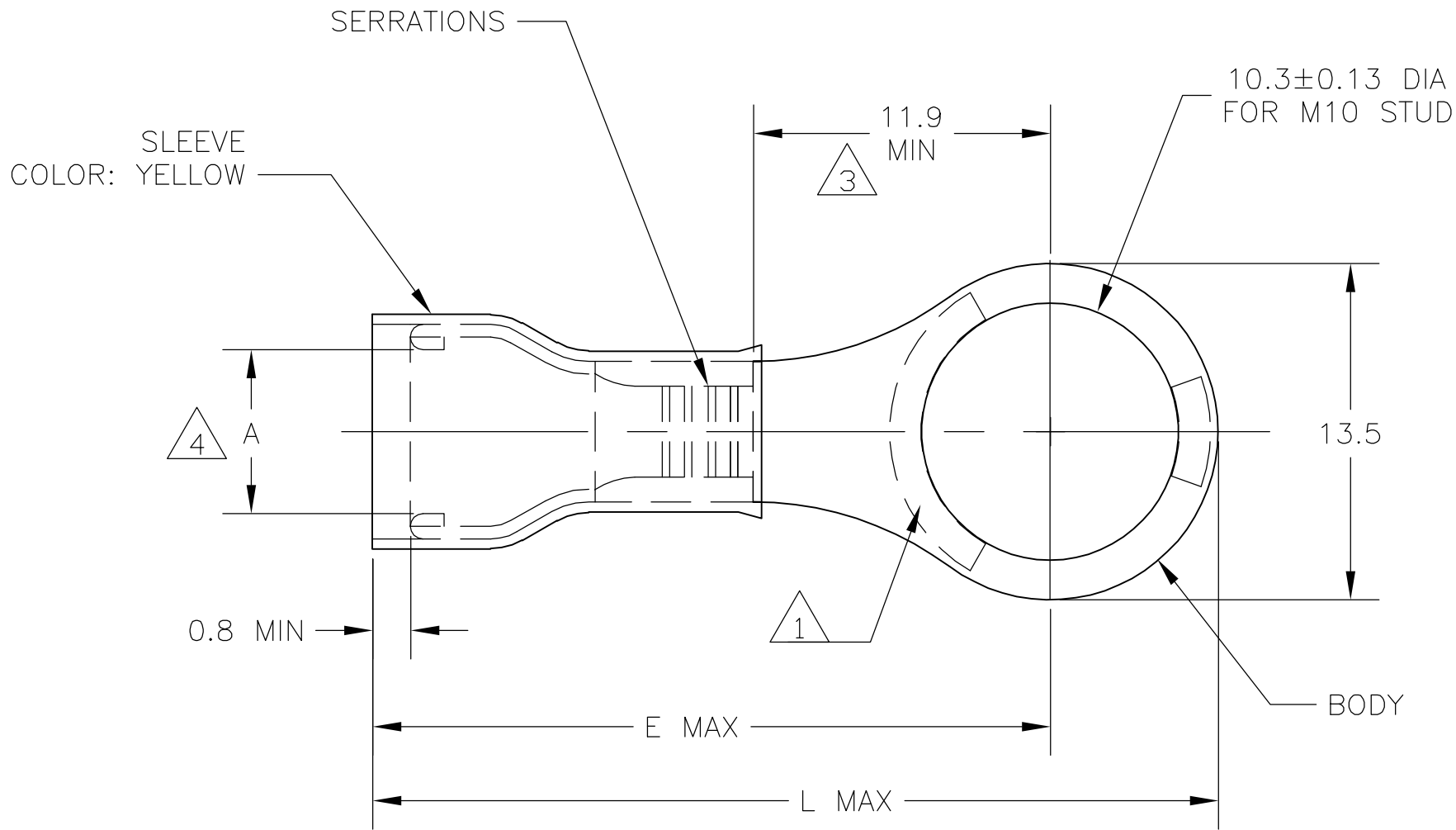

- 1 STAMP "AMP 12-10\*", LOCATION APPROX AS SHOWN.
- 2 TONGUE THICKNESS IS 1.0±0.05
- 3 APPLIES TO EDGE OF METAL WIRE BARREL TO CENTER OF STUD HOLE.
- 4 WIRE INSULATION DIA RANGE SEE TABLE
- 5 BODY - COPPER PER ASTM B-152 SLEEVE - COPPER PER ASTM B-152 INSULATION - NYLON
- 6 BODY - TIN PL PER ASTM B-545 SLEEVE - TIN PL PER ASTM B-545 INSULATION - COLOR - YELLOW
- 7 105°C MAX OPERATING TEMPERATURE.
- 8 300 VOLT MAX
- 9 2.62-6.64mm<sup>2</sup> [5,180 - 13,100 CMA] SOLID OR STRANDED
- 10 OBSOLETE WITHOUT REPLACEMENT.

4.3-7.6	29.2	36.1	500	LOOSE PIECE	10 130207-1
3.8-6.4	26.9	33.8	500	LOOSE PIECE	130207
A 4	E	L	QTY	PACKAGE TYPE	PART NO
THIS DRAWING IS A CONTROLLED DOCUMENT.			DWN jr_ruth 10APR07	Tyco Electronics Corporation Harrisburg, PA 17105-3608	
DIMENSIONS: mm INCHES			CHK T MICHIELUTTI 10APR07		
TOLERANCES UNLESS OTHERWISE SPECIFIED:			APVD T MICHIELUTTI 10APR07	NAME	
0 PLC ± - 1 PLC ± 0.1 2 PLC ± - 3 PLC ± - 4 PLC ± - ANGLES ± 5°			PRODUCT SPEC -	TERMINAL RING TONGUE, PIDG, WIRE SIZE 12-10	
MATERIAL 5			FINISH 6	APPLICATION SPEC -	RESTRICTED TO -
-			WEIGHT -	SIZE A3	CAGE CODE 00779
CUSTOMER DRAWING			DRAWING NO C-130207	SCALE 4:1	SHEET 1 OF 1
				REV F	

单击下面可查看定价，库存，交付和生命周期等信息

[>>TE Connectivity\(泰科\)](#)