

THIS DRAWING IS UNPUBLISHED. RELEASED FOR PUBLICATION, 19  
 © COPYRIGHT 19 BY AMP INCORPORATED, HARRISBURG, PA. ALL INTERNATIONAL RIGHTS RESERVED. AMP PRODUCTS MAY BE COVERED BY U.S. AND FOREIGN PATENTS AND/OR PATENTS PENDING.

REVISIONS					
P	ZONE	LTR	DESCRIPTION	DATE	APPROVED
✓		0	REL. W/O 7-086 F		
✓		A	REV PER ECN DF-1585	NF 10.89	DS
✓		B	REV PER DF-1659	TW 2/23/90	DS
		C	REV PER 0600-1666-94	TA 11/94	JGM

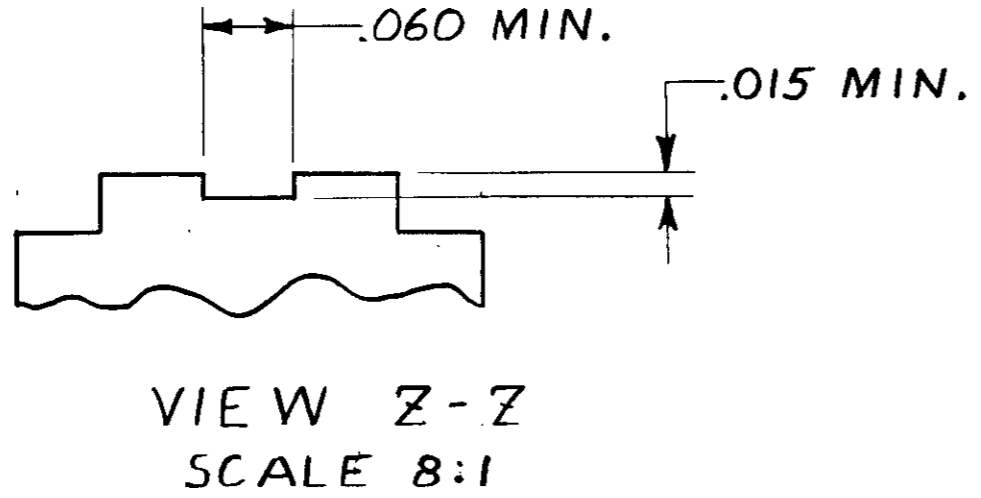
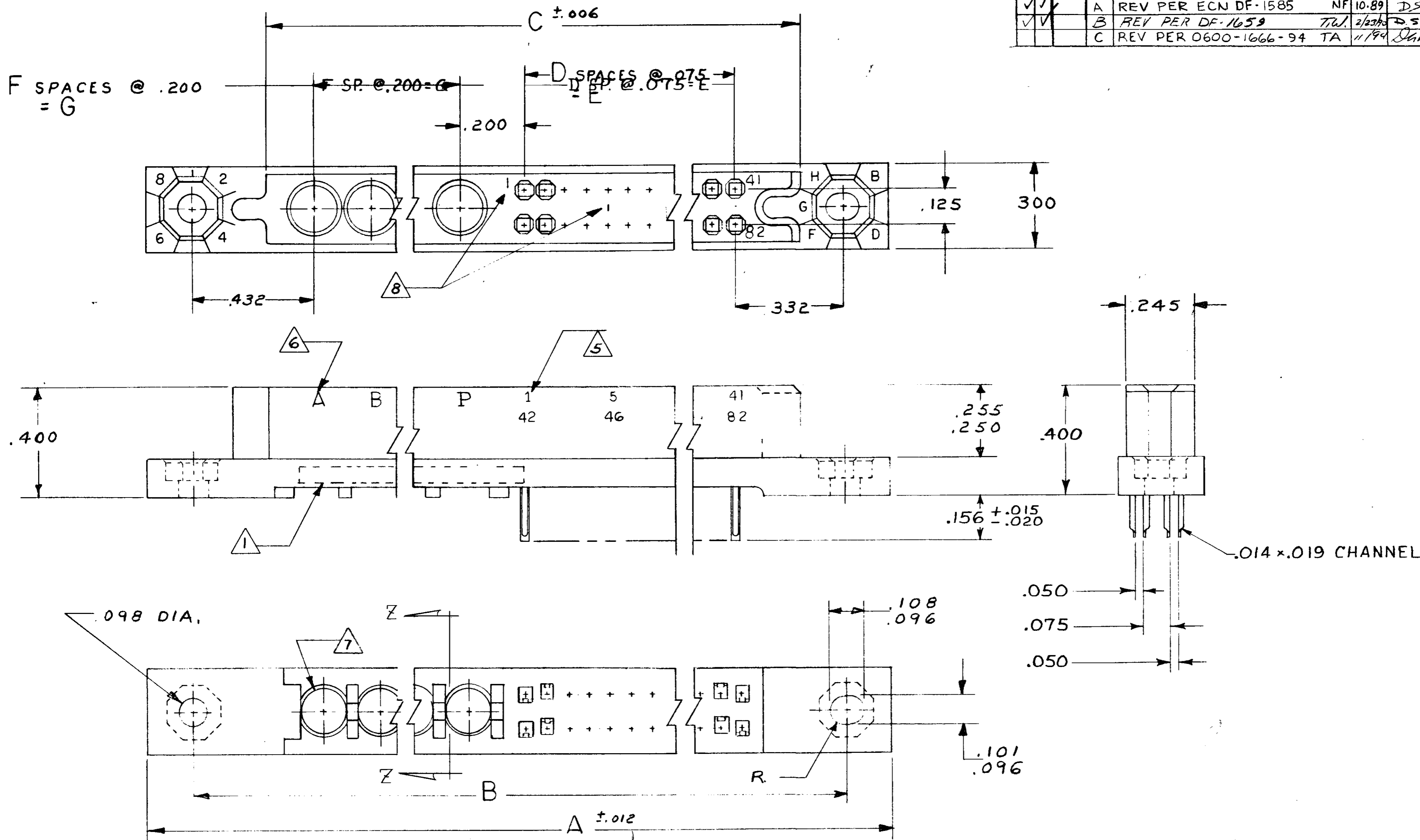

UNLESS OTHERWISE SPECIFIED DIMENSIONS ARE IN INCHES. TOLERANCES ON: DECIMALS $\pm .010$ ANGLES $\pm$	CONTRACT NO	AMP INCORPORATED Harrisburg, Pa. 17105	
	DR <i>W. Siefert</i> 10-30-87	NAME RECEPTACLE ASSEMBLY	
	CHK <i>J.P. Schob</i> 12-3-87	750 SERIES BOX, W/ COAX	
	APPR <i>J.F. Schob</i> 12-11-87	CAVITIES, EXTERNAL KEYING,	
MATERIAL	APPR <i>J.F. Schob</i> 12/11/87	.014 x .019 CHANNEL CONT.	
FINISH	DSGN APPD	SIZE C	FSCM NO 00779
	OTHER APPD	DRAWING NO 445088	
		SCALE 4:1	SHEET 1 of 3

THIS DRAWING IS UNPUBLISHED.  
 RELEASED FOR PUBLICATION  
 BY AMP INCORPORATED. ALL RIGHTS RESERVED.

LOC	DIST	REVISIONS			
P	LTR	DESCRIPTION	DATE	DWN	APVD
DF	FO				
	C	SEE SHEET 1	-	-	-

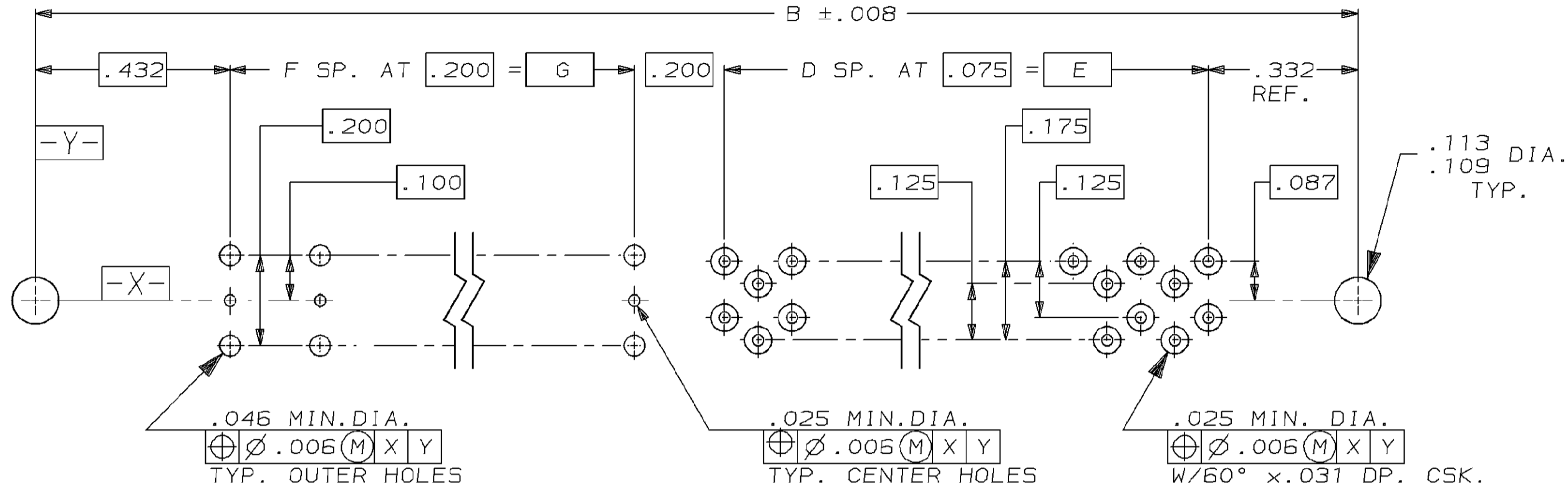

P.C. BOARD LAYOUT  $\triangle 9$   $\triangle 11$

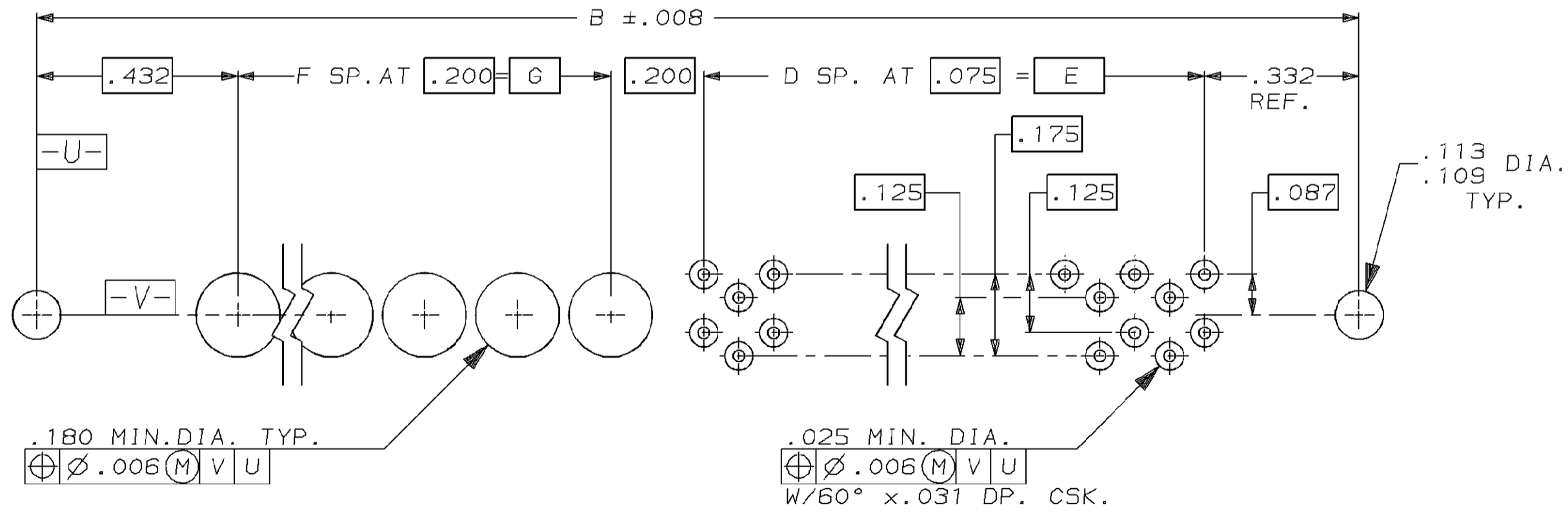

P.C. BOARD LAYOUT  $\triangle 9$   $\triangle 10$

<small>THIS DRAWING IS A CONTROLLED DOCUMENT FOR AMP INCORPORATED. IF IT IS SUBJECT TO CHANGE AND THE CONTROLLING ENGINEERING ORGANIZATION SHOULD BE CONTACTED FOR THE LATEST REVISION.</small>		DWN T. ALEXANDER 10-14-94 CHK D. MILLER 11-18-94 APVD B. FOLEY 11-18-94	<b>AMP</b> AMP Incorporated Harrisburg, PA 17105-3608
DIMENSIONS: mm TOLERANCES UNLESS OTHERWISE SPECIFIED: 0 PLC ± 1 PLC ± 2 PLC ± 3 PLC ±.005 I. 133 4 PLC ± ANGLES ±0°30' FINISH -		NAME RCPT ASSEMBLY, 750 SERIES BOX, WITH (12) OR (?) COAX CAVITIES, EXTERNAL KEYING, .014 X .019 CHANNEL CONTACT PRODUCT SPEC - APPLICATION SPEC - WEIGHT -	SIZE A2 CAGE CODE 00779 DRAWING NO. C-445088
MATERIAL -		CUSTOMER DRAWING	SCALE 1:1 SHEET 2 OF 3 REV C

THIS DRAWING IS UNPUBLISHED. RELEASED FOR PUBLICATION  
 BY AMP INCORPORATED. ALL RIGHTS RESERVED.

LOC	DIST	REVISIONS			
P	LTR	DESCRIPTION	DATE	DWN	APVD
DF	FO	C	SEE SHEET 1	-	-

- 1 "AMP", P/N & DATE CODE, INK STAMPED WHITE THIS APPROXIMATE AREA.
  - 2 HOUSING MATERIAL: DIALLYL PHTHALATE. COLOR: BLUE.
  - 3 CONTACT MATERIAL: BERYLLIUM COPPER.
  - 4 CONTACT FINISH: .000030 GOLD IN CONTACT AREA WITH .000100 TIN-LEAD ON SOLDER POSTS OVER .000030 NICKEL ALL OVER.
  - 5 NUMBERS INDICATING EVERY FIFTH (5) CAVITY STAMPED WHITE, THIS SIDE ONLY.
  - 6 COAX POSITIONS, ( SEE TABLE ), STAMPED WHITE, THIS SIDE ONLY.
  - 7 WILL ACCEPT MICROMINIATURE COAX CONTACT, SEE AMP DATA SHEET 80-600. P.C. BOARD MOUNT CONTACTS MUST BE MATED DURING SOLDERING. INSERT CONTACTS THIS SIDE.
  - 8 NUMBERS TO BE STAMPED WHITE, .062 HIGH CHARACTERS, (SEE TABLE) AND LINES INDICATING EVERY FIVE (5) CAVITIES ON MATING FACE. THREE (3) DIGIT NUMBERS ARE OMITTED DUE TO AREA RESTRICTIONS.
  - 9 CONNECTOR SIDE.
  - 10 RECOMMENDED BOARD LAYOUT FOR CONNECTORS WITH VERTICAL COAX CABLE CONTACTS.
  - 11 RECOMMENDED BOARD LAYOUT FOR CONNECTORS WITH VERTICAL COAX P.C. BOARD CONTACTS.
  - 12 COAX POSITIONS, (A,B,C,D,E,F,G,H,J,K,L & P), FOR DASH ONE (-1).  
COAX POSITIONS, (A,B,C,D,E,F & G), FOR DASH TWO (-2).
13. CONTACT HOLES WILL ALWAYS START IN THE UP POSITION AT TONGUE END AND THEN ALTERNATE IN THE REMAINING CAVITIES.

	A THRU G	1 - 55/110	1.200 [30.48]	6	4.050 [102.87]	54	5.814 [147.68]	6.214 [157.84]	6.504 [165.20]	7	110	445088-2
	A THRU P	1 - 41/82	2.200 [55.88]	11	3.000 [76.20]	40	5.764 [146.41]	6.164 [156.57]	6.454 [163.93]	12	82	445088-1
	COAX IDENTIFICATION	CAVITY IDENTIFICATION	G	F	E	D	C	B	A	COAX POSITION	CONTACT POSITION	PART NUMBER

THIS DRAWING IS A CONTROLLED DOCUMENT FOR AMP INCORPORATED. IF IS SUBJECT TO CHANGE AND THE CONTROLLING ENGINEERING ORGANIZATION SHOULD BE CONTACTED FOR THE LATEST REVISION.

DWN T. ALEXANDER 10-14-94	<b>AMP</b> AMP Incorporated Harrisburg, PA 17105-3608 NAME RCPT ASSEMBLY, 750 SERIES BOX, WITH (12) OR (?) COAX CAVITIES, EXTERNAL KEYING, .014 X .019 CHANNEL CONTACT SIZE A2 CAGE CODE 00779 DRAWING NO C-445088 SCALE 1:1 SHEET 3 OF 3 REV C
CHK D. MILLER 11-18-94	
APVD B. FOLEY 11-18-94	
PRODUCT SPEC - APPLICATION SPEC -	
MATERIAL -	WEIGHT -
CUSTOMER DRAWING	

单击下面可查看定价，库存，交付和生命周期等信息

[>>TE Connectivity\(泰科\)](#)