

THIS DRAWING IS UNPUBLISHED. RELEASED FOR PUBLICATION FEB ,2006.

© COPYRIGHT 2006 By - ALL RIGHTS RESERVED.

LOC	DIST	REVISIONS					
E	B	P	LTR	DESCRIPTION	DATE	DWN	APVD
		D		ECR-14-011285	28SEP2014	RZ	MY

- NOTES:
- 1 PACKAGE ONE COMPLETE CONNECTOR IN HEAT SEALED, LABELED BAG/ 200 PER SHIPPING BOX. LABELED PER TEC-107-115.
 - 2 100 TRAY PACK IN ACCORDANCE WITH AMP SPEC 107-3275
 - 3 Au PLATING
 - 4 Ni PLATING
 - 5 THIS ITEM MUST BE WHITE

6 HAND TOOL : 9-1478240-0

7 DIE SET : 9-1478245-0

8 ELECTRICAL CHARACTERISTICS

FREQUENCY RANGE:	DC - 4 GHz
NOMINAL IMPEDANCE:	50 Ohm
INSULATION RESISTANCE:	5000 MOhm
WORKING VOLTAGE:	500 Volts RMS at Sea Level
DIELECTRIC WITHSTAND VOLTAGE:	1500 Volts RMS Max
CONTACT RESISTANCE:	
CENTER CONTACT:	1.50 mOhm Max
OUTER CONTACT:	1.00 mOhm Max
VSWR @ 4GHz:	1.65:1 Max
INSERTION LOSS dB @ x 3 GHz:	0.20 Max

9 MECHANICAL CHARACTERISTICS

CABLE RETENTION FORCE:	43.5N Min
MOUNT NUT RECOMMENDED TORQUE:	4 Nm
DURABILITY:	500 Cycles Min

10 ENVIRONMENTAL CHARACTERISTICS

OPERATING TEMPERATURE:	-65 to +165 DegC
------------------------	------------------

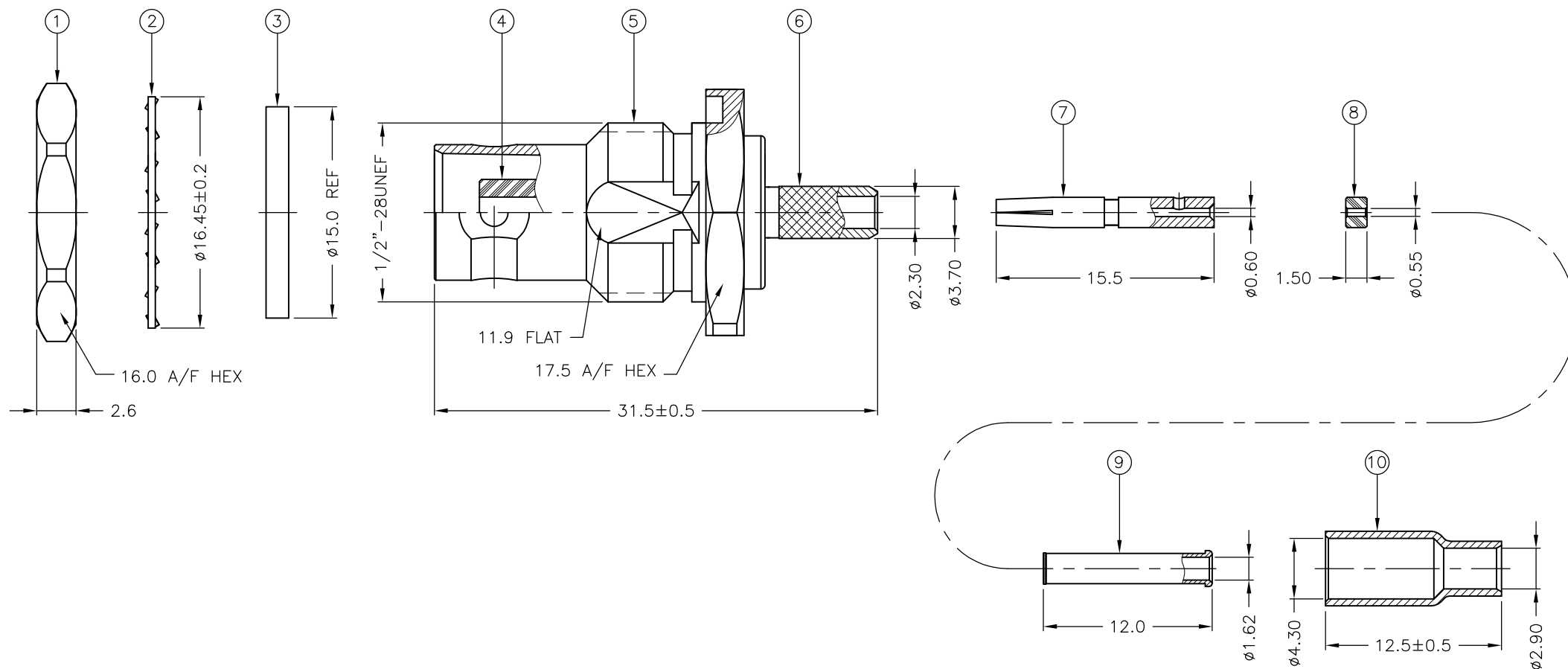

QTY	UNIT	MATERIAL	DESCRIPTION	ITEM
1	1	BRASS	FERRULE	10
1	1	BRASS	SLEEVE	9
1	1	PTFE	INSULATOR	8
1	1	PHOSPHOR BRONZE	CONTACT	7
1	1	BRASS	BODY II	6
1	1	BRASS	BODY I	5
1	1	PTFE	INSULATOR	4
1	1	SILICONE	GASKET	3
1	1	BRASS	LOCKWASHER	2
1	1	BRASS	HEX NUT	1
6--0	1--0	MATERIAL	DESCRIPTION	ITEM

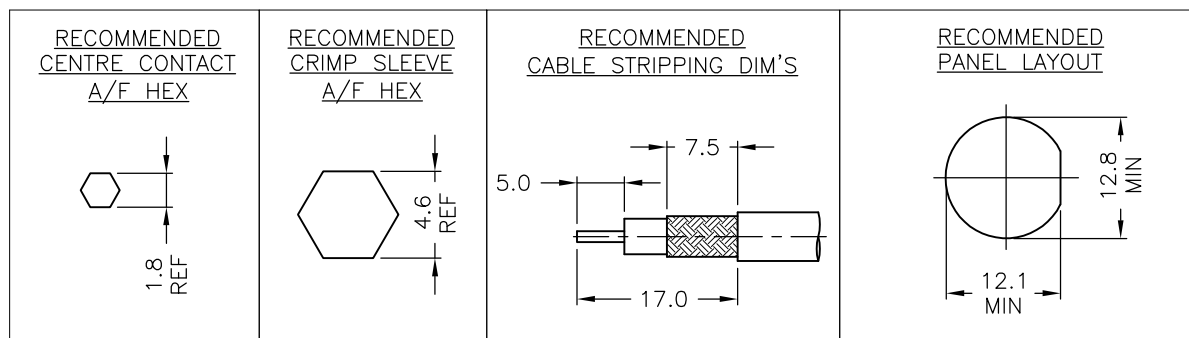

THIS DRAWING IS A CONTROLLED DOCUMENT.

DWN	J.SANDWELL	01FEB06
CHK	S.PARLOW	01FEB06
APVD	F.WHEELER-KING	01FEB06
PRODUCT SPEC	108-112000	
APPLICATION SPEC	-	
WEIGHT	-	

STE TE Connectivity

NAME: BNC BULKHEAD JACK REAR MOUNT CRIMP 50 OHM RG174A/U, 188A/U, 316/U, URM95, KX3B, KX22A

SIZE	CAGE CODE	DRAWING NO	RESTRICTED TO
A3	00779	C-1337548	-

CUSTOMER DRAWING SCALE NTS SHEET 1 OF 2 REV D

THIS DRAWING IS UNPUBLISHED. RELEASED FOR PUBLICATION FEB ,2006.
 © COPYRIGHT 2006 By - ALL RIGHTS RESERVED.

LOC	DIST	REVISIONS					
E	B	P	LTR	DESCRIPTION	DATE	DWN	APVD
		D		ECR-14-011285	28SEP2014	RZ	MY

COMPONENTS

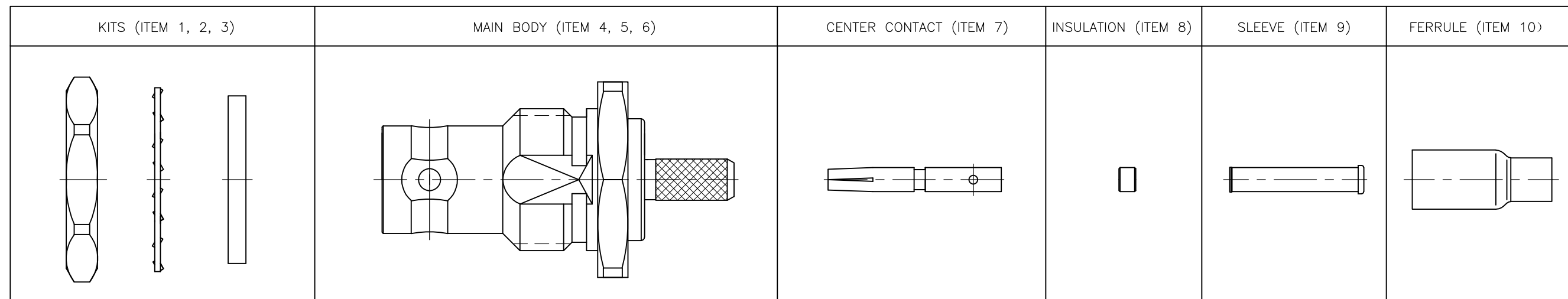

ASSEMBLY INSTRUCTIONS

STEP 1: PREPARATION OF CABLE

1. TRIM CABLE TO DIMENSIONS SHOWN. BE CAREFUL TO AVOID NICKING THE BRAID.
2. REMOVE ANY RESIDUAL PLASTIC FROM CENTER CONDUCTOR.

STEP 2: ASSEMBLE FERRULE, SLEEVE AND INSULATOR TO CABLE

1. SLIDE FERRULE ONTO JACKET OF CABLE AS SHOWN,
2. FLARE THE BRAID WIRES, AND SLIDE SLEEVE ONTO DIELECTRIC OF CABLE AS SHOWN.
3. SLIDE INSULATOR ONTO CENTER CONDUCTOR OF CABLE.

STEP 3: CRIMP/SOLDERING CENTER CONTACT TO CABLE

1. INSERT STEP 2 CABLE ASSEMBLY INTO CENTER CONTACT.
2. USING 1.8 (.071") HEX CRIMP TOOLING, OR SOLDERING CENTER CONTACT WITH CABLE.
3. PAY ATTENTION TO THE CRIMP AREA.

STEP 4: CRIMP FERRULE TO CABLE

1. INSERT STEP 3 CABLE ASSEMBLY INTO CONNECTOR BODY UNTIL CENTER CONTACT IS SEATED WITH ALL BRAID WIRES ON OUTSIDE OF CONNECTOR BODY.
2. SLIDE FERRULE OVER BRAID WIRES AND CRIMP AS CLOSE TO BODY AS POSSIBLE USING 4.6 (.181") HEX CRIMP TOOLING. PAY ATTENTION TO THE CRIMP AREA.

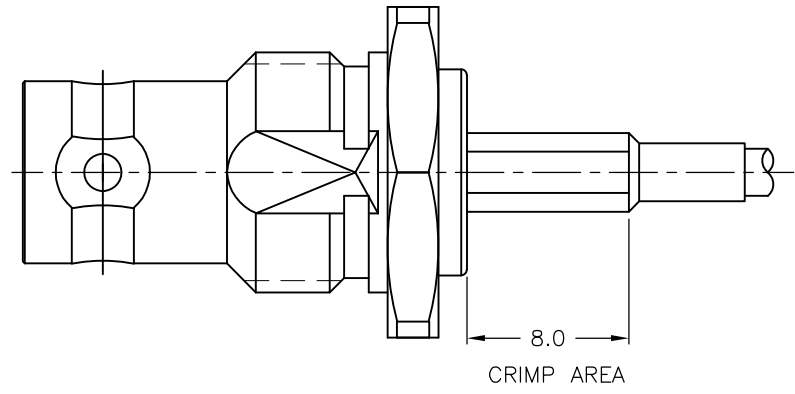

THIS DRAWING IS A CONTROLLED DOCUMENT.		DWN	J.SANDWELL	01FEB06															
DIMENSIONS: mm		CHK	S.PARLOW	01FEB06															
		APVD	F.WHEELER-KING	01FEB06															
<p>TOLERANCES UNLESS OTHERWISE SPECIFIED:</p> <table border="1"> <tr><td>0 PLC</td><td>± -</td></tr> <tr><td>1 PLC</td><td>± -</td></tr> <tr><td>2 PLC</td><td>± -</td></tr> <tr><td>3 PLC</td><td>± -</td></tr> <tr><td>4 PLC</td><td>± -</td></tr> <tr><td>ANGLES</td><td>± -</td></tr> <tr><td>FINISH</td><td>± -</td></tr> </table>		0 PLC	± -	1 PLC		± -	2 PLC	± -	3 PLC	± -	4 PLC	± -	ANGLES	± -	FINISH	± -	PRODUCT SPEC	NAME	
0 PLC	± -																		
1 PLC	± -																		
2 PLC	± -																		
3 PLC	± -																		
4 PLC	± -																		
ANGLES	± -																		
FINISH	± -																		
MATERIAL	SEE TABLE	APPLICATION SPEC	SIZE		A3														
		WEIGHT	CAGE CODE		00779														
		CUSTOMER DRAWING		DRAWING NO	C-1337548														
		SCALE		SHEET	2 OF 2														
		RESTRICTED TO		REV	D														

单击下面可查看定价，库存，交付和生命周期等信息

[>>TE Connectivity\(泰科\)](#)