

LOC	DIST	REVISIONS			
P	LTR	DESCRIPTION	DATE	OWN	APVD
A		RELEASED	27OCT2006	LAM	JW
B		ECO-07-001858	31JAN2007	LAM	JW
C		ECR-08-020353	13AUG2008	AL	SY

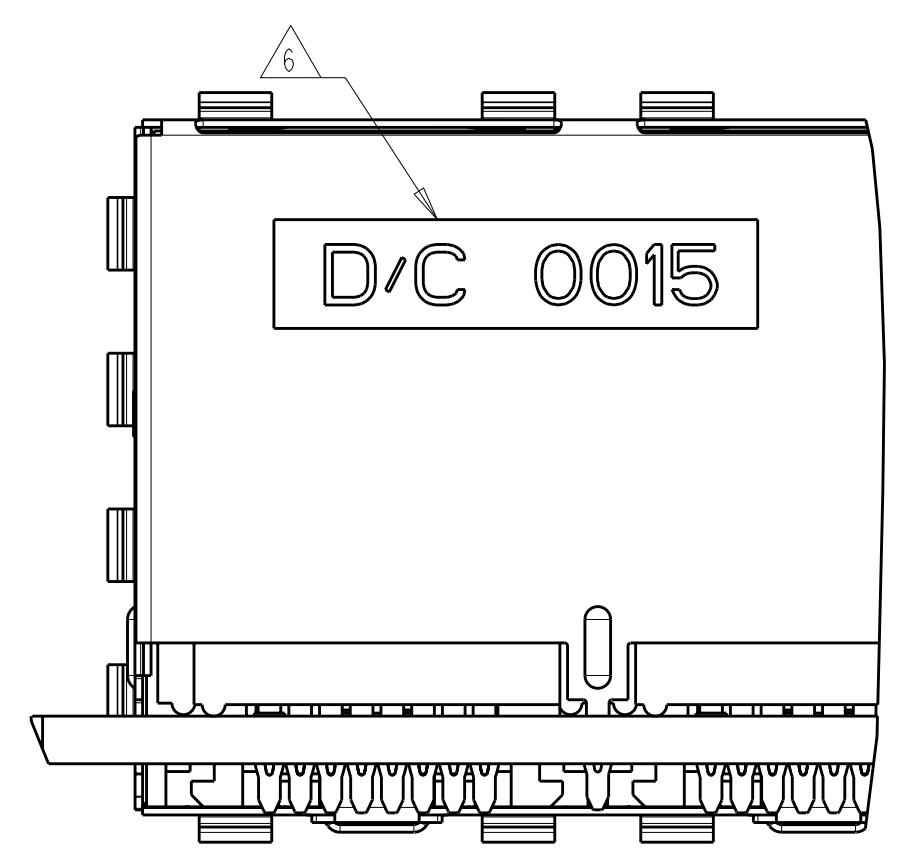

**ATCA PANEL AND
 PRINTED CIRCUIT BOARD
 ASSEMBLY LAYOUT**

- MATERIAL:
 HOUSING: PBT POLYESTER, BLACK, UL 94V-0
 TERMINALS: 0.33 THICK PHOSPHOR BRONZE PLATED WITH 1.27µm MINIMUM THICK HARD GOLD IN LOCALIZED AREA AND 2.0µm MINIMUM THICK MATTE TIN IN COMPLIANT PIN TERMINAL AREA OVER 1.27µm MINIMUM THICK NICKEL UNDERPLATE
 SHIELD: 0.25 THICK COPPER ALLOY PLATED WITH 2.03µm MINIMUM TIN OVER 1.27 µm MINIMUM NICKEL
 GROUND CLIP: 0.25 THICK COPPER ALLOY PRE-PLATED WITH 2.03µm MINIMUM MATTE TIN OVER 1.27µm MINIMUM NICKEL
 - JACK CAVITY CONFORMS TO FCC RULES AND REGULATIONS, PART 68 SUBPART F.
- 3 MAXIMUM PIN LENGTH 3.40 FROM TOP SURFACE OF PC BOARD
 4 FINISHED PLATED THROUGH HOLE DIAMETER - ANNULAR RING DIAMETER 1.3 TO 1.5
 5 DATUMS AND BASIC DIMENSIONS ESTABLISHED BY CUSTOMER
 6 DATE CODE LOCATED ON REAR OF PART APPROXIMATELY AS SHOWN
 7 CONTACTS ARE NOT INTENDED TO BE ALIGNED WITH EACH OTHER

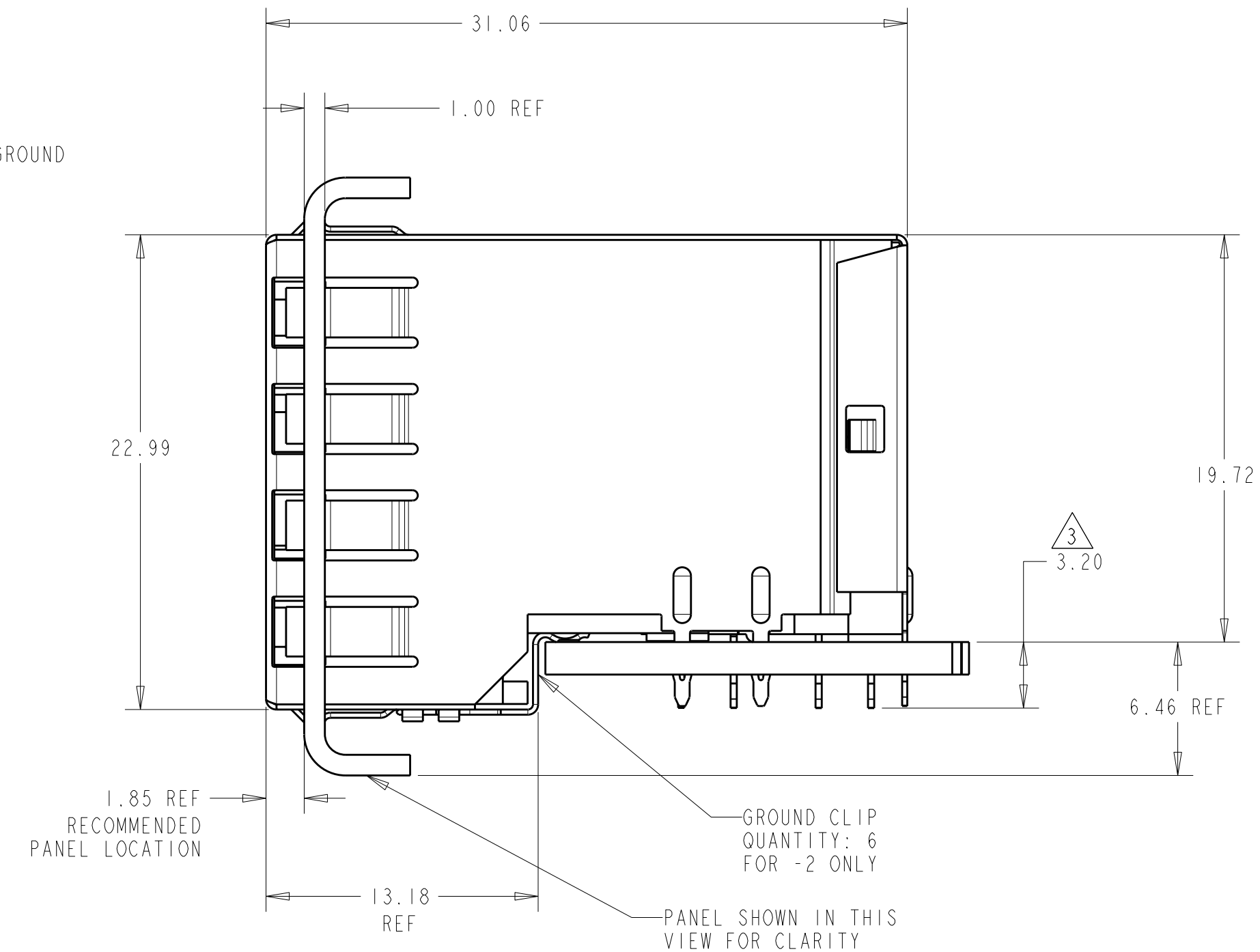
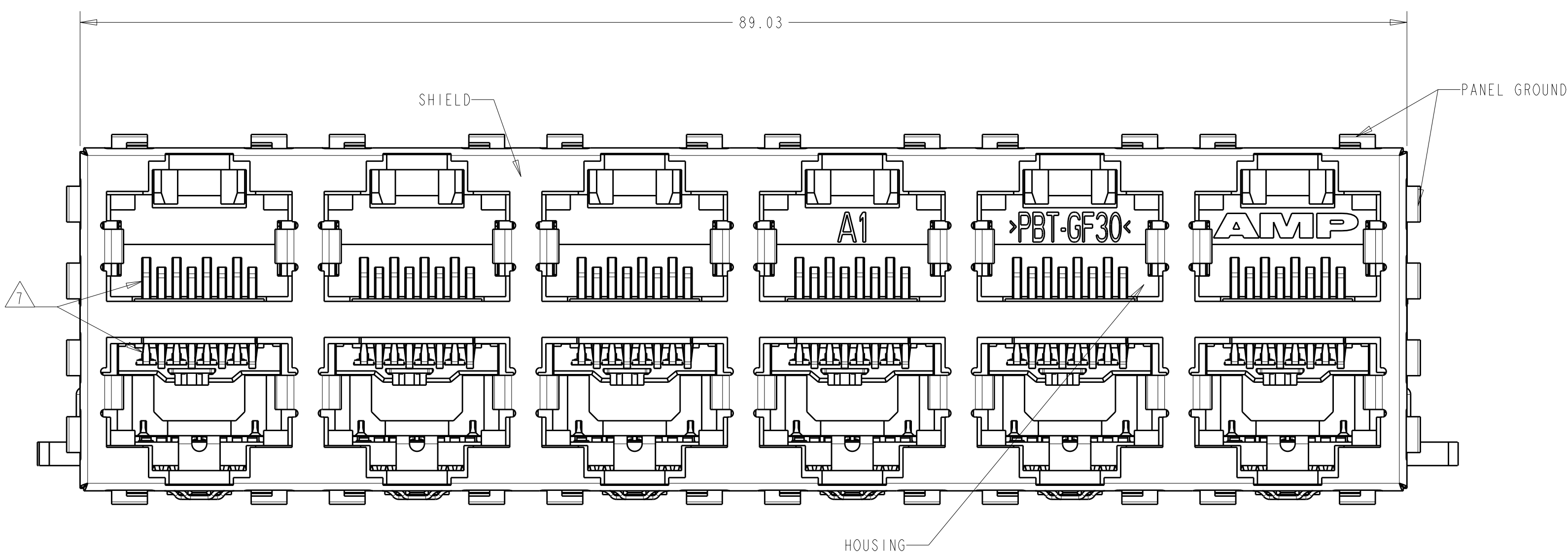
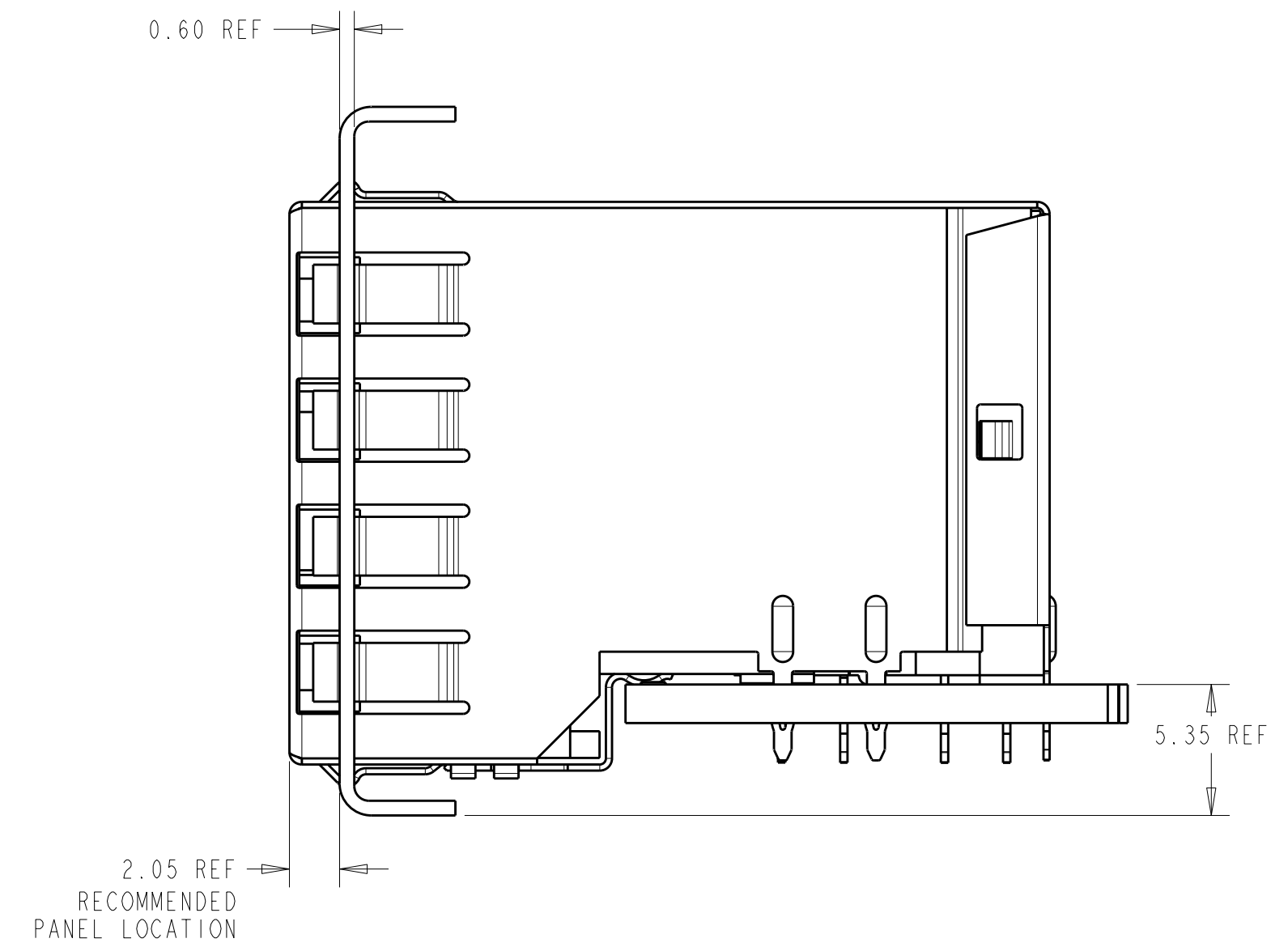

**AMC PANEL AND
 PRINTED CIRCUIT BOARD
 ASSEMBLY LAYOUT**

M DIM	DESCRIPTION	PART NUMBER
15.88	WITH GROUND CLIP	1888508-2
16.13	WITHOUT GROUND CLIP	1888508-1

DIMENSIONS: mm 		TOLERANCES UNLESS OTHERWISE SPECIFIED: 9 PLC ± 2 PLC ±0.13 5 PLC ± 4 PLC ± ANGLES ±1° FINISH SEE NOTE 1		DWN L.A.MAYER 25OCT2006 CHK J.WESTMAN 25OCT2006 APVD S.FLICKINGER 25OCT2006 NAME STACKED MODULAR JACK ASSEMBLY, 2 X 6, 8 POSN, RJ45, SHIELDED, PANEL GROUND, OFFSET, CAT 5 PRODUCT SPEC 108-1854 APPLICATION SPEC 114-2160 WEIGHT - CUSTOMER DRAWING		Tyco Electronics Corporation Harrisburg, PA 17105-3608 SIZE CAGE CODE DRAWING NO. RESTRICTED TO A 00779 C-1888508 SCALE 4:1 SHEET 1 OF 2 REV C	
-----------------------	--	---	--	---	--	--	--

LOC	DIST	REVISIONS					
		P	LTB	DESCRIPTION	DATE	DWN	APVD
AA	00	-	-	SEE SHEET 1	-	-	-

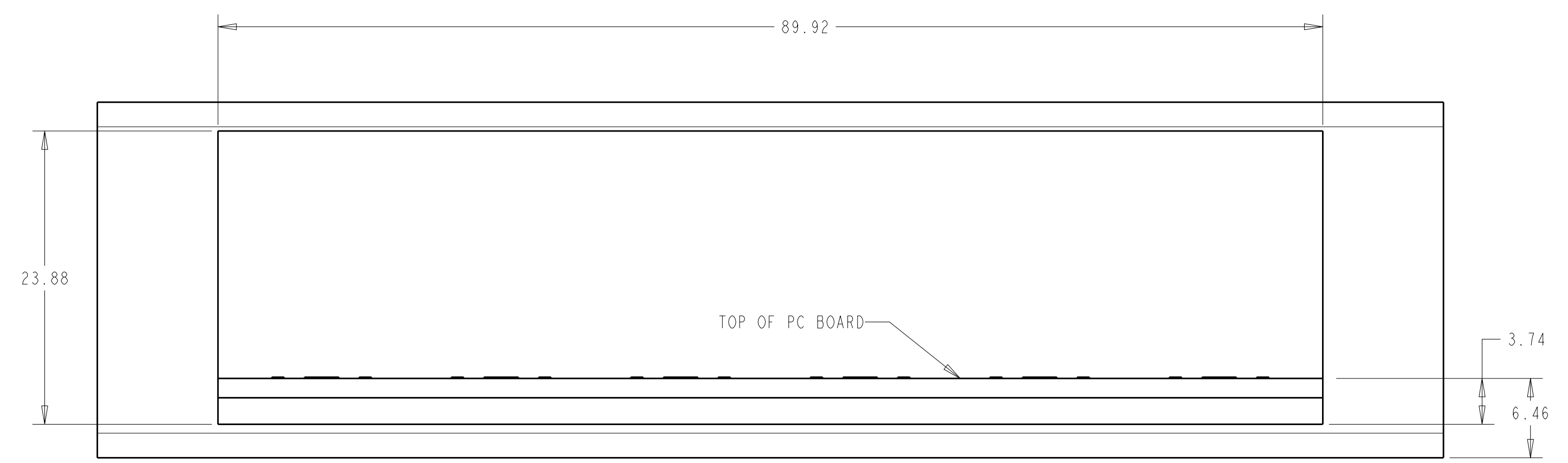

**ATCA PANEL AND
PRINTED CIRCUIT BOARD LAYOUT**
SCALE 3:1

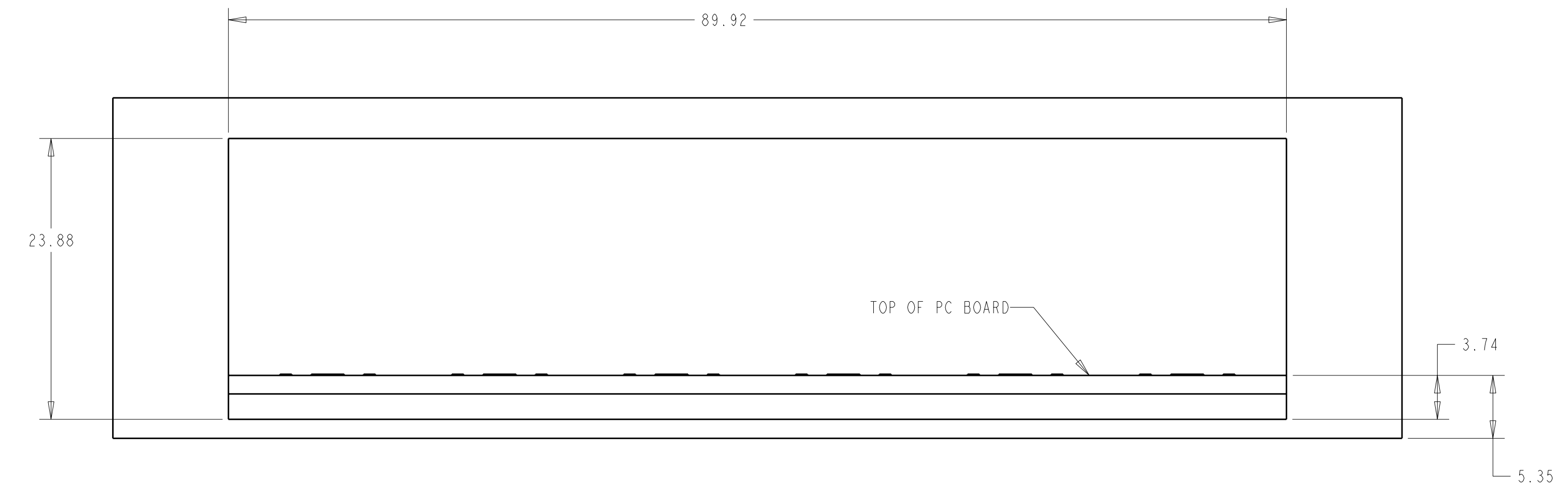

**AMC PANEL AND
PRINTED CIRCUIT BOARD LAYOUT**
SCALE 3:1

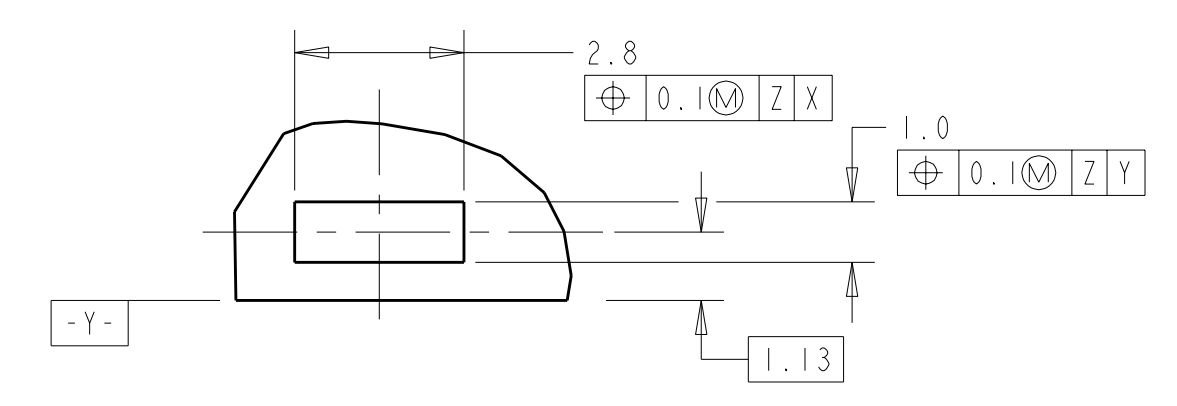
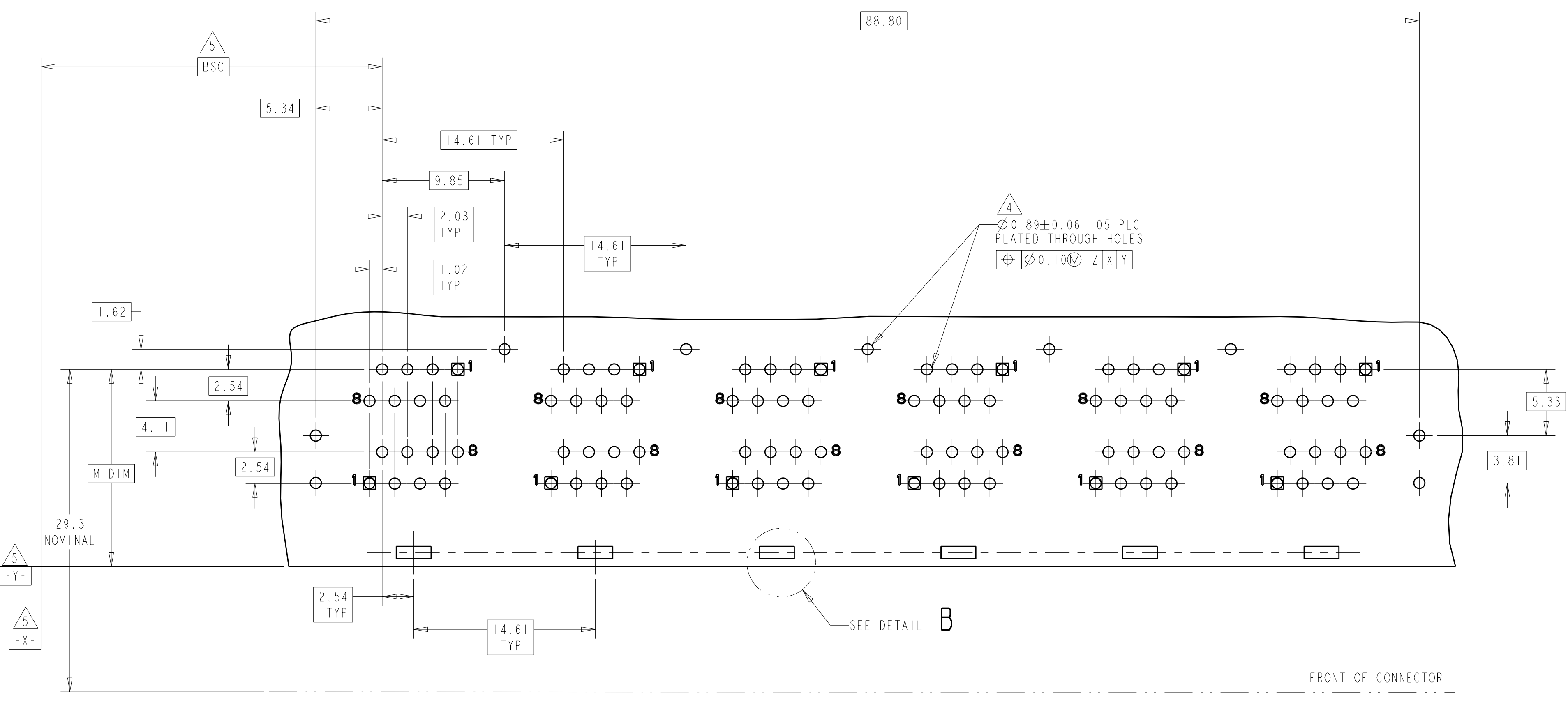

DETAIL B
SCALE 8:1
PLATED PADS REQUIRED FOR
1888508-2 (PRODUCT WITH
GROUNDING CLIPS)
6 PLC

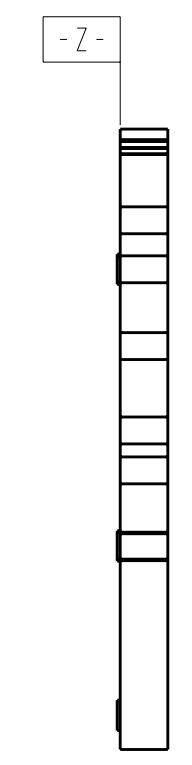

DIMENSIONS: mm 		TOLERANCES UNLESS OTHERWISE SPECIFIED: 9 PLC ± 1 PLC ±0.13 5 PLC ± 4 PLC ± ANGLES ±1°		DWN L.A. MAYER 25OCT2006 CHK J. WESTMAN 25OCT2006 APVD S. FLICKINGER 25OCT2006 PRODUCT SPEC 108-1854 APPLICATION SPEC 114-2160 WEIGHT - CUSTOMER DRAWING		Tyco Electronics Corporation Harrisburg, PA 17105-3608 NAME STACKED MODULAR JACK ASSEMBLY, 2 X 6, 8 POSN, RJ45, SHIELDED, PANEL GROUND, OFFSET, CAT 5 SIZE CAGE CODE DRAWING NO. RESTRICTED TO A1100779 C=1888508 SCALE 4:1 SHEET 2 OF 2 REV C	
-----------------------	--	--	--	--	--	---	--

单击下面可查看定价，库存，交付和生命周期等信息

[>>TE Connectivity\(泰科\)](#)