

LOC	DIST	REV	DATE	DWN	APVD
A1	-	A	16 JUL 2013	PV	CE
A1	-	A1	29 MAY 2018	SM	CF
A2	-	A2	24 SEP 2020	CK	GL

DELIVERY CONDITION AS SHOWN
Lieferzustand wie gezeigt

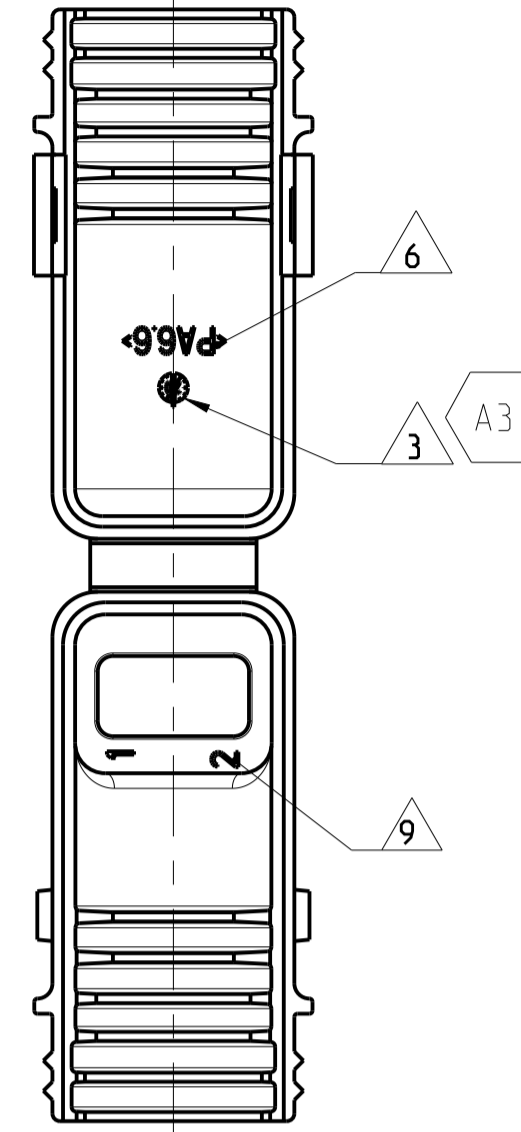
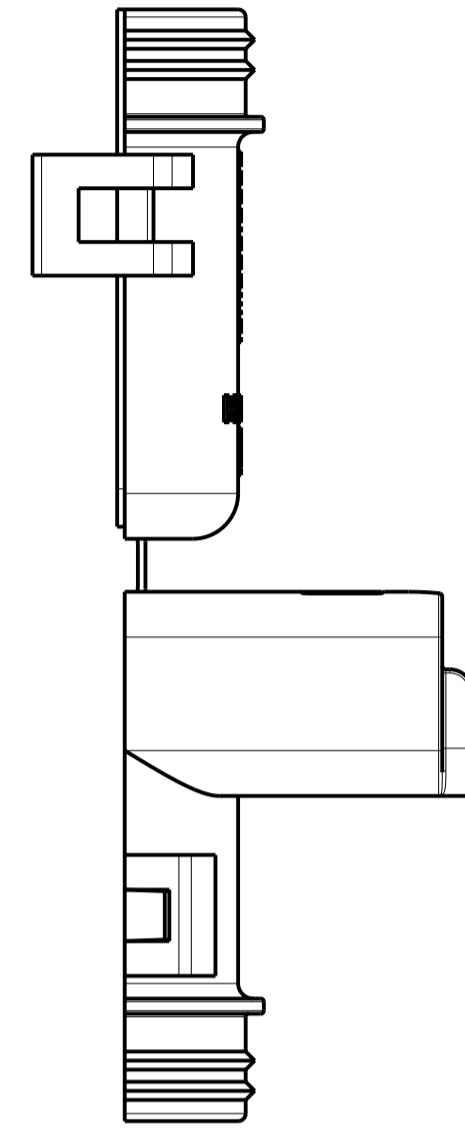
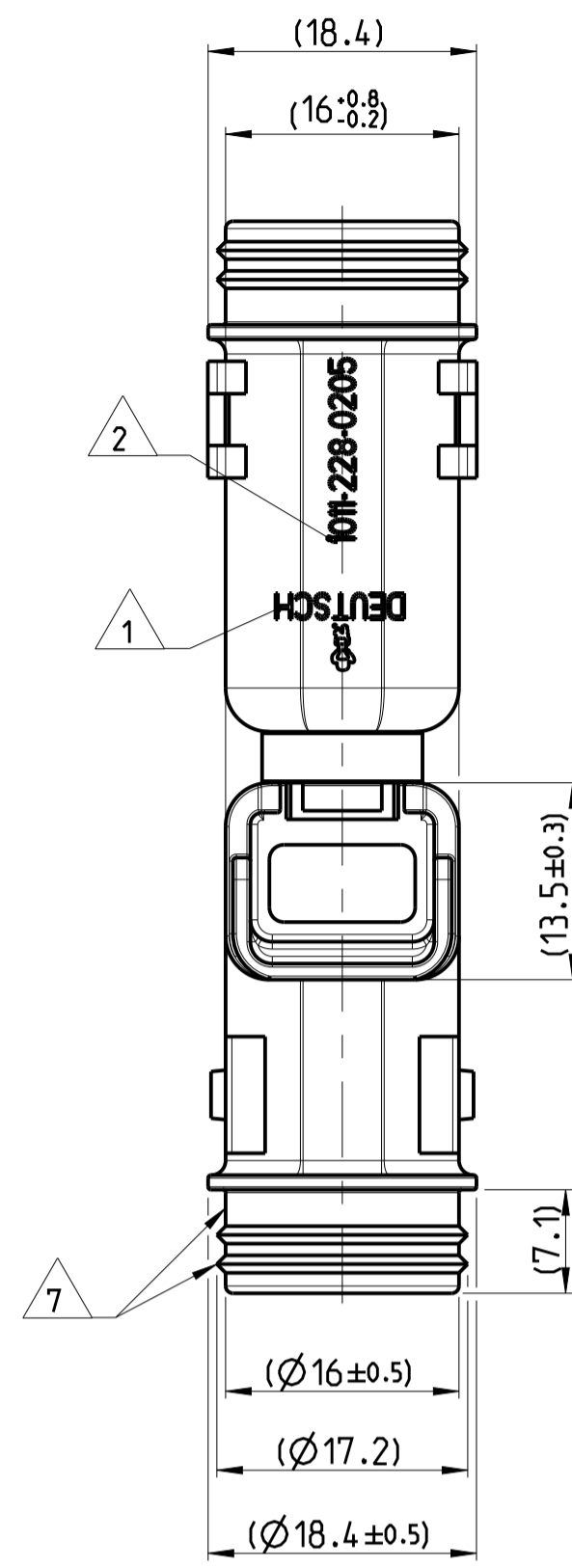

NOTES
Bemerkungen

- 1 DEUTSCH LOGO
DEUTSCH Logo
- 2 DEUTSCH PART-NO
DEUTSCH Teil-Nr.
- 3 PRODUCTION DATE
Produktionsdatum
- 4 BULK PACKAGING IN CORRUGATED BOX
Schuetfgut im Karton
- 5 MALFUNCTION CAUSED BY LAQUER IS
NOT COVERED BY TE WARRANTY
Funktionsbeeintraehtigung durch Lackieren liegt
nicht im Einfluss und Gewaehrleistungsumfang von TE
- 6 MATERIAL MARKING ACCORDING TO VDA 260
Werkstoffkennzeichnung nach VDA 260
- 7 FOR HEAT-SHRINK TUBING AND TUBE WITH TIE WRAP
Fuer Schrumpfschlauch und Schlauch mit Kabelschelle
- 8 FOR CORRUGATED TUBES: NW 6/7.5/8.5/10
Fuer Wellrohre: NW 6/7.5/8.5/10
- 9 MOULD CAVITY MARKING (IF NECESSARY)
Nestmarkierung (falls notwendig)
- 10 CAVITY MARKING
Kammerbezeichnung
- 11 MATED WITH ALL MODIFICATION OF DT06-02S
(WITHOUT ANY WELDED / MOUNTED PARTS)
Passend zu allen Varianten von DT06-02S
(ohne verschweißte / montierte Teile)
- 12 BASED ON THE HINGE MECHANISM OF THE CAP.
THE DELIVERY CONDITION CAN BE DIFFERENT
TO THE SHOWN STATUS.
Basierend auf dem Klappmechanismus der Kappe, kann der
Lieferzustand von der dargestellten Ansicht abweichen.

CLOSED (MOUNTED) CONDITION AS SHOWN
Geschlossener (montierter) Zustand wie gezeigt

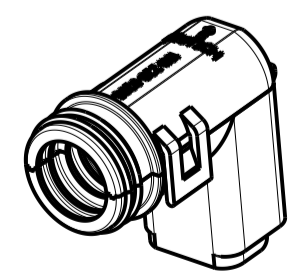
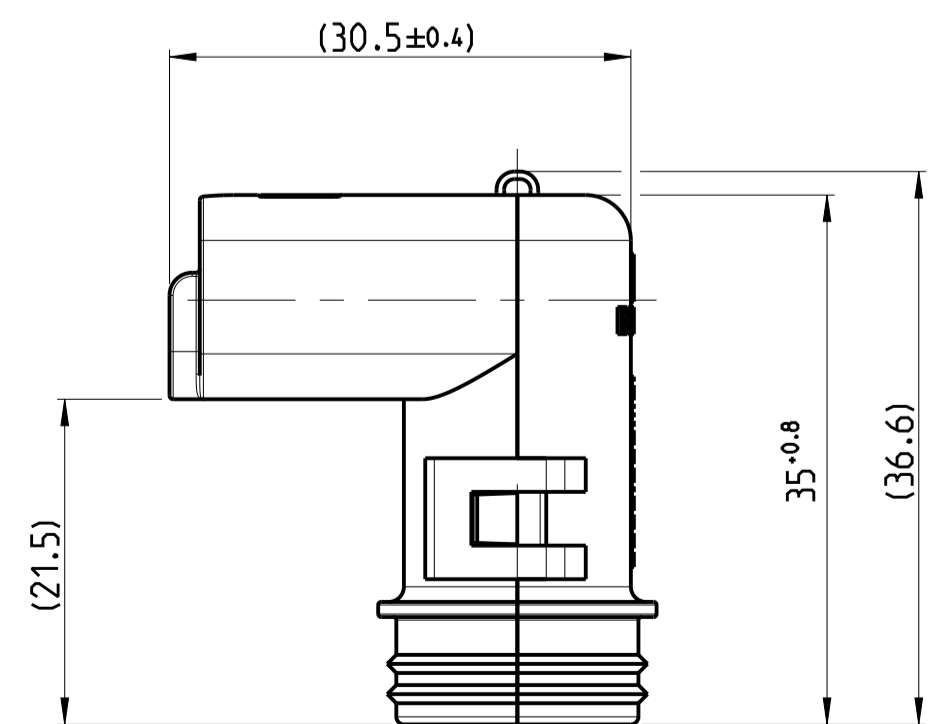
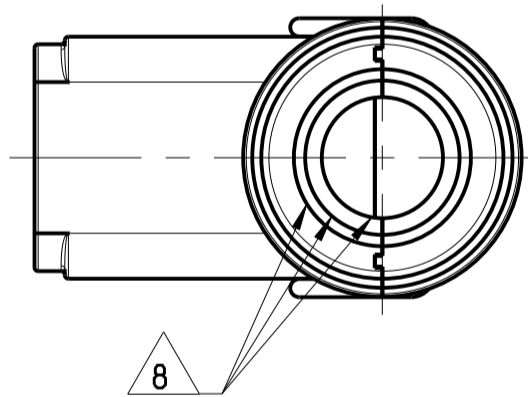

SCALE 1:1
Maßstab

SECTION B-B
Schnitt
SCALE 5:1
Maßstab

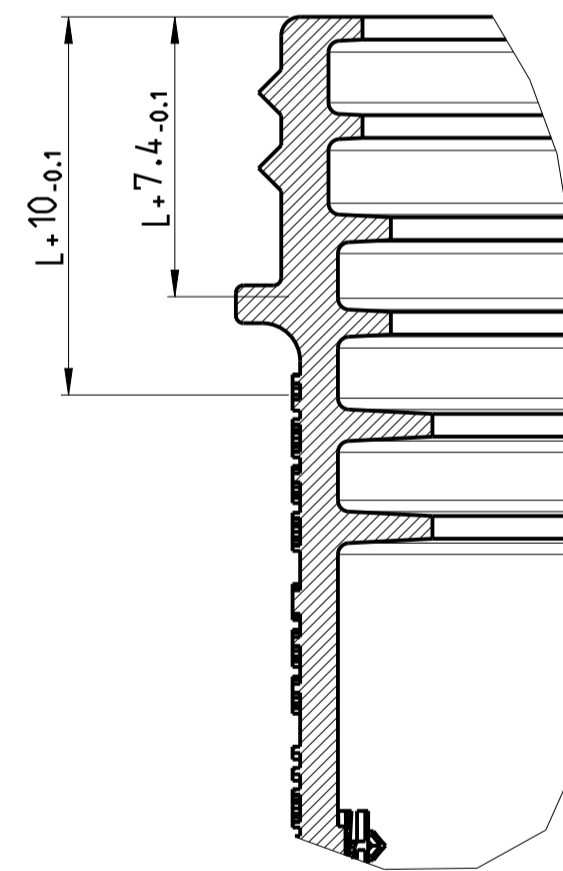

L+ = ADD LENGTH FOR CORRUGATED TUBE
zus. Länge des Wellrohres

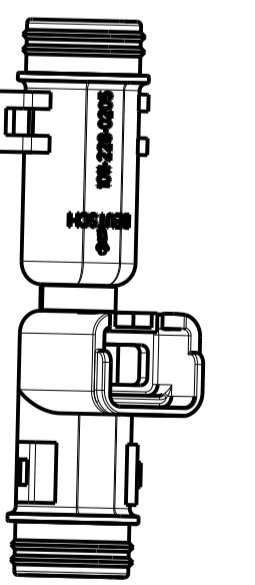

SCALE 1:1
Maßstab

TOLERANCES UNLESS OTHERWISE SPECIFIED ACC. TO DIN 16901-140 CENTRIC TO NOMINAL DIMENSION, EDITION 1982-11 SHALL APPLY. Freimaßtoleranzen nach DIN 16901-140. Es gilt die Ausgabe 1982-11.		DIESE ZEICHNUNG IST EIN KONTROLLIERTES DOKUMENT. BEMASSUNGEN UND TOLERANZEN GEMAESS GPS (ISO STANDARDS).	
THIS DRAWING IS A CONTROLLED DOCUMENT. DIMENSIONING AND TOLERANCING PER GPS (ISO STANDARDS)		DWN PRAVEENA 16 JUL 2013	17 JUL 2013
DIMENSIONS: MASSENMASSENER mm		CHK C.FINZER	APVD C.FINZER 17 JUL 2013
TOLERANCES UNLESS OTHERWISE SPECIFIED: ALL GENERAL DIMENSIONS PLC ±0.1 2 PLC ±0.2 3 PLC ±0.3 4 PLC ±0.4		NAME COVER, DT06-02S-BS090 Kappe, DT06-02S-BS090 BACKSHELL STRAIGHT (90 DEGREE)	
FINISH/SCHLÜSSELFARBE SEE TABLE Siehe Tabelle		SCALE 1:1	
MATERIAL SEE TABLE Siehe Tabelle		WEIGHT SEE TABLE Siehe Tabelle	
Customer Drawing		/KUNDENZEICHNUNG	

ORDER-NO. Bestell-Nr.	REV.	WEIGHT (g)	MATERIAL	COLOUR Farbe	DESCRIPTION Beschreibung	ITEM
1011-228-0205	A	4.55	NYLON 6/6	BLACK schwarz	COVER WITHOUT STRAIN RELIEF Kappe ohne Zugentlastung	1

		RESTRICTED TO NUR FÜR
SIZE A1	CAGE CODE 00779	DRAWING NO. 1011-228-0205
SCALE 2:1		SHEET 1 OF 1
REV A2		REV A2

单击下面可查看定价，库存，交付和生命周期等信息

[>>TE Connectivity\(泰科\)](#)