

THIS DRAWING IS UNPUBLISHED. RELEASED FOR PUBLICATION
 © COPYRIGHT - BY TYCO ELECTRONICS CORPORATION. ALL RIGHTS RESERVED.

LOC	DIST	REVISIONS					
AJ	16	P	LTR	DESCRIPTION	DATE	DWN	APVD
			AC	REVISED PER EC 0S14-0456-04	13DEC05	BL	JL

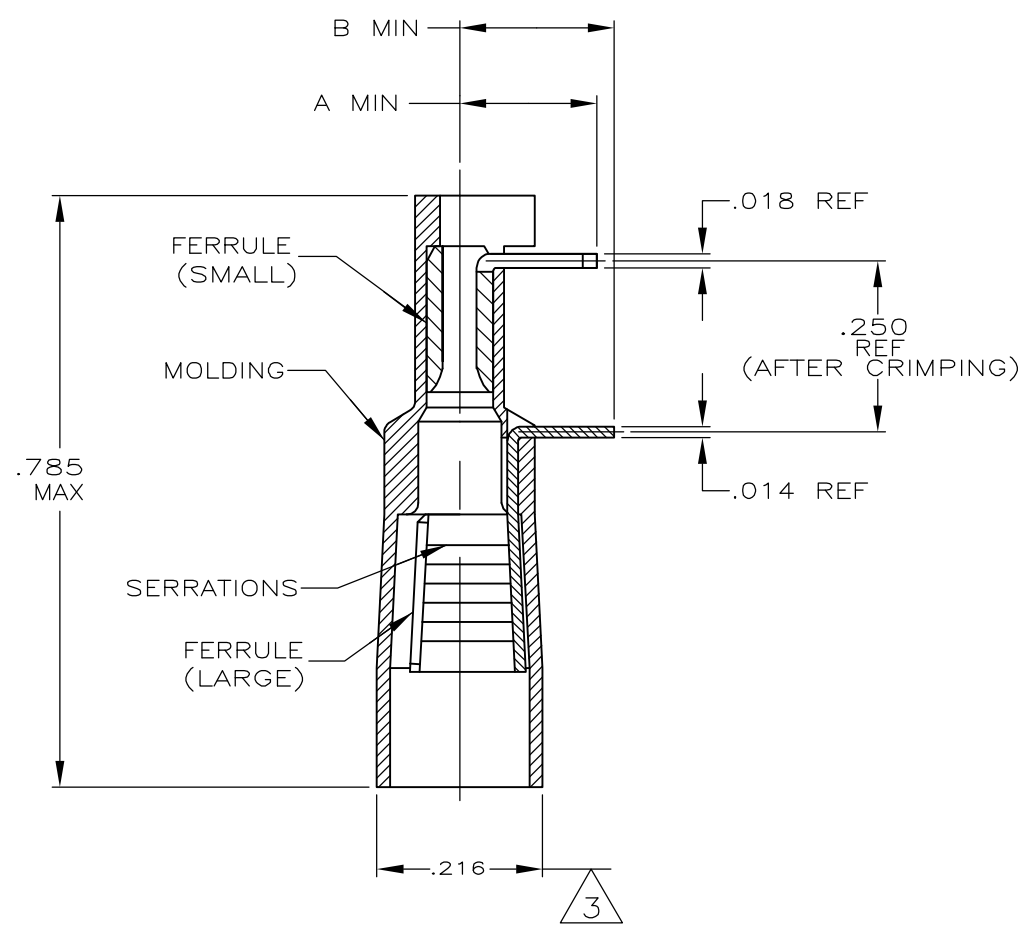
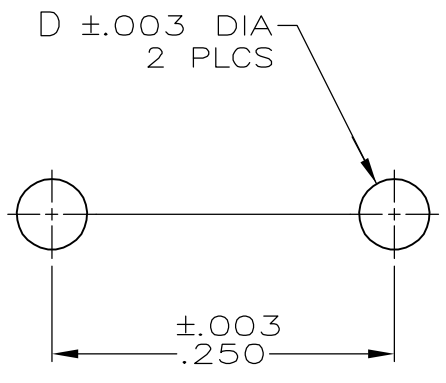
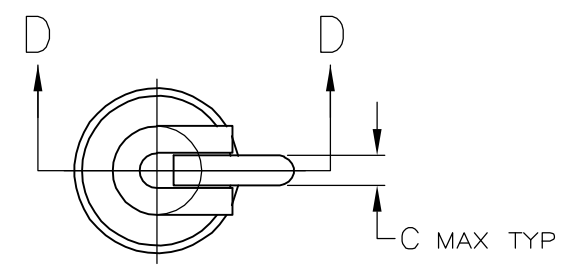

1. LARGE FERRULE: FOR .110 MAX DIA BRAID
2. SMALL FERRULE: FOR #26 TO #28 AWG WIRE
3. THE AVERAGE OF THE OUT OF ROUNDNESS DIMENSIONS MUST FALL WITHIN THE SPECIFIED TOLERANCE
4. MATERIAL;
 MOLDING: NYLON PER MIL-M-20693
 LARGE FERRULE: BRASS PER ASTM-B-36
 SMALL FERRULE: COPPER PER QQ-C-576
5. FINISH;
 MOLDING: COLOR-NATURAL
 LARGE FERRULE: MATTE TIN PL PER ASTM-B-545 .000040 MIN THK OVER NICKEL PL PER QQ-N-290
 SMALL FERRULE: MATTE TIN PL PER ASTM-B-545

6. INSTRUCTION SHEET NO.: 408-2469

OBSOLETE	FOR 1/8" BOARD	.155 OZ	LOOSE PIECE	.040	.036	.260	.255	53230-5
	FOR 1/8" BOARD	.155 OZ	LOOSE PIECE	.046	.042	.260	.255	53230-3
OBSOLETE	FOR 1/16" BOARD	.148 OZ	LOOSE PIECE	.046	.042	.175	.160	53230-1

USE	WEIGHT	PACKAGED	D	C	B	A	ASSY NO	
THIS DRAWING IS A CONTROLLED DOCUMENT.		DWN	1/10/92					Tyco Electronics Corporation Harrisburg, PA 17105-3608
DIMENSIONS: INCHES		CHK	1/23/92					
TOLERANCES UNLESS OTHERWISE SPECIFIED: 0 PLC ± - 1 PLC ± - 2 PLC ± - 3 PLC ± .008 4 PLC ± - ANGLES ± 5°		APVD	1/23/92					NAME TERMASHIELD ASSY,PRE-INSULATED, FUNNEL ENTRY
MATERIAL		PRODUCT SPEC	-					
FINISH		APPLICATION SPEC	-					RESTRICTED TO
4		WEIGHT	-					SIZE
5		CUSTOMER DRAWING		A3 00779		C-53230		
SCALE			1:1		SHEET		1 OF 1	
REV			AC					

SECTION D-D

单击下面可查看定价，库存，交付和生命周期等信息

[>>TE Connectivity\(泰科\)](#)