

THIS DRAWING IS UNPUBLISHED. RELEASED FOR PUBLICATION  
 © COPYRIGHT - By - ALL RIGHTS RESERVED.

LOC	DIST	REVISIONS			
P	LTR	DESCRIPTION	DATE	DWN	APVD
AF	50	S2	REVISED PER ECO-11-004917	11MAR11	RK HMR

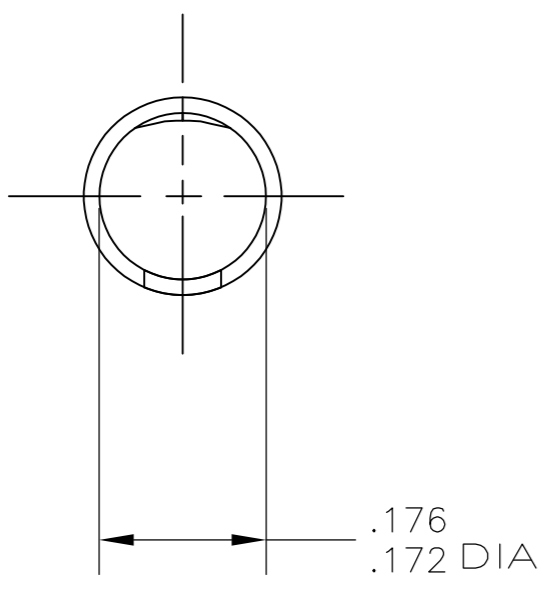

- 1 CONTINUOUS STRIP ON REELS
- 2 TIN PL .000080 MIN PER MIL-T-10727
- 3 .000080 MIN TIN PLATE PER MIL-T-10727 OVER .000050 MIN NICKEL UNDERPLATE PER QQ-N-290.
- 4 .000030 MIN GOLD PLATE OVER .000050 MIN NICKEL UNDERPLATE PER QQ-N-290.
- 5 .000200 MIN SILVER OVER .000050 MIN NICKEL UNDERPLATE PER QQ-N-290
- 6 WIRE SIZE IS #18-#14 AWG
- 7 INSULATION RANGE IS .090-.125 DIA
- 8 PREPRODUCTION - FASR REQ
- 9 PRELIMINARY - NOT FOR PRODUCTION
- 10 OBSOLETE PARTS: OBSOLETE CIS STREAMLINING PER D.RENAUD/D.SINISI

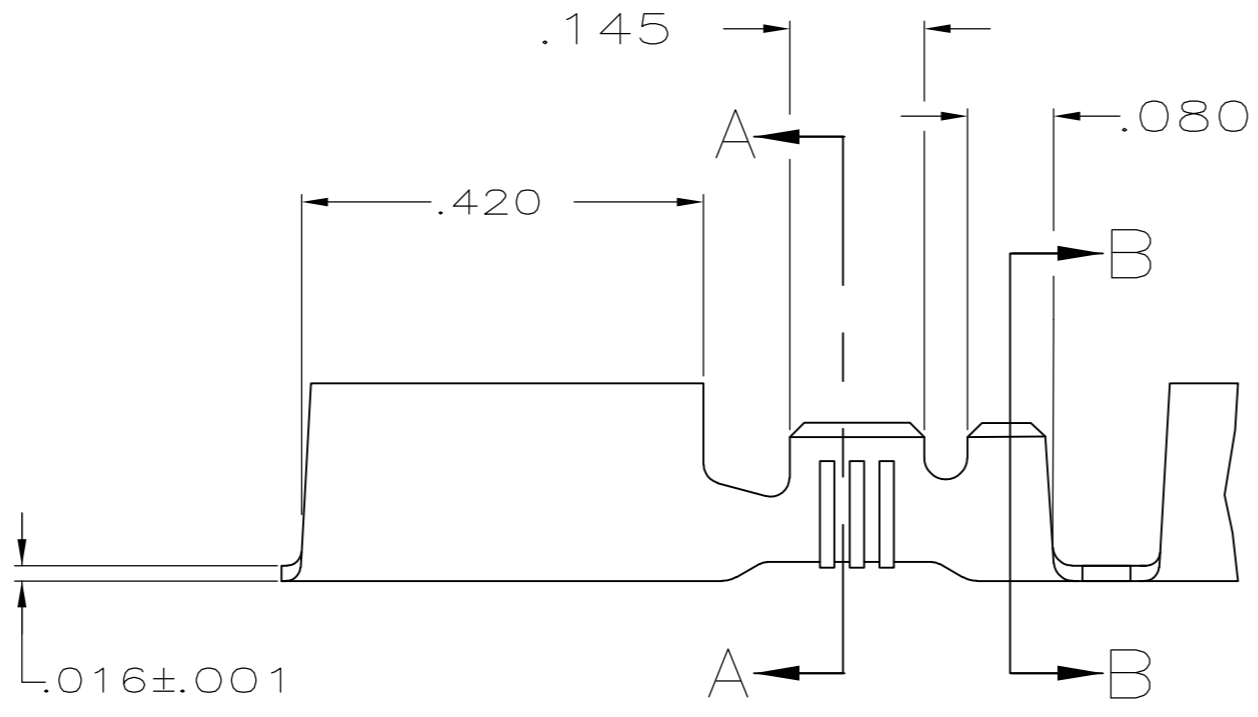
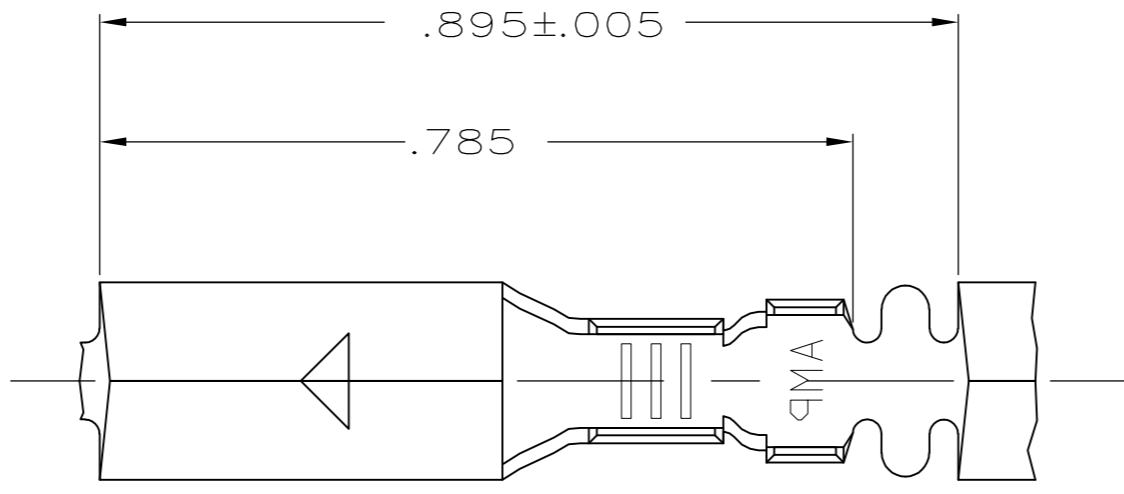
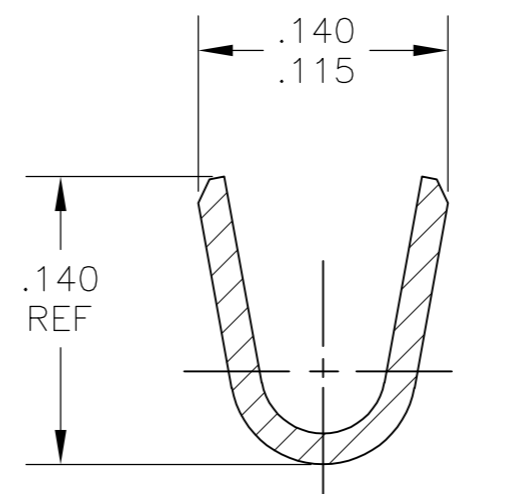

SECTION A-A  
SCALE 10:1

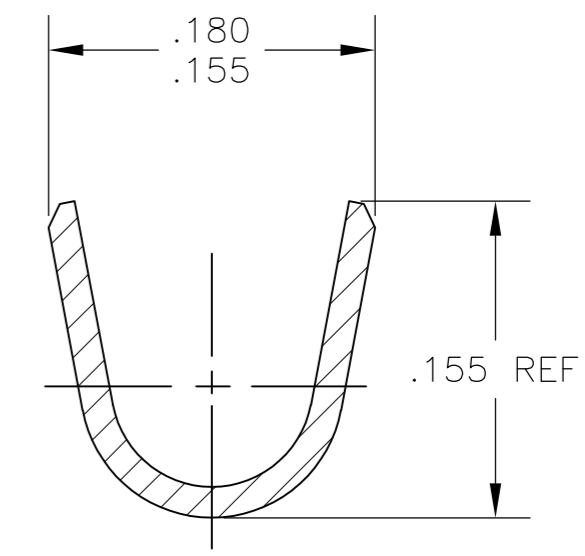

SECTION B-B  
SCALE 10:1

5	9	60798-8
4	8	60798-7
3		60798-6
2		60798-4
-		60798-2
FINISH		PART NO.

TYPE	WIDTH	STRIP LENGTH ±.015	TYPE	WIDTH	±.002 HEIGHT	WIRE
F OR O	.140	.210	F	.100	.077	14
					.067	16
					.061	18
INSUL BARREL CRIMP			WIRE BARREL CRIMP			

THIS DRAWING IS A CONTROLLED DOCUMENT.

DWN	P FORTNEY	12/13/88
CHK	MS FEHER	6/14/89
APVD	D DECKER	6/14/89
PRODUCT SPEC		
APPLICATION SPEC		
WEIGHT	-	
MATERIAL	#4 HARD BRASS	SEE TABLE

TE Connectivity

RECEPTACLE, SHUR PLUG, .180 DIA

SIZE	A2	CAGE CODE	00779	DRAWING NO	60798	RESTRICTED TO	-
SCALE	5:1	SHEET	1 of 1	REV	S2		

单击下面可查看定价，库存，交付和生命周期等信息

[>>TE Connectivity\(泰科\)](#)