

THIS DRAWING IS UNPUBLISHED. RELEASED FOR PUBLICATION  
 © COPYRIGHT - By - ALL RIGHTS RESERVED.

REVISIONS				
P	LTR	DESCRIPTION	DATE	APVD
	F4	REVISED PER ECO-16-018632	05APR2017	SK PO

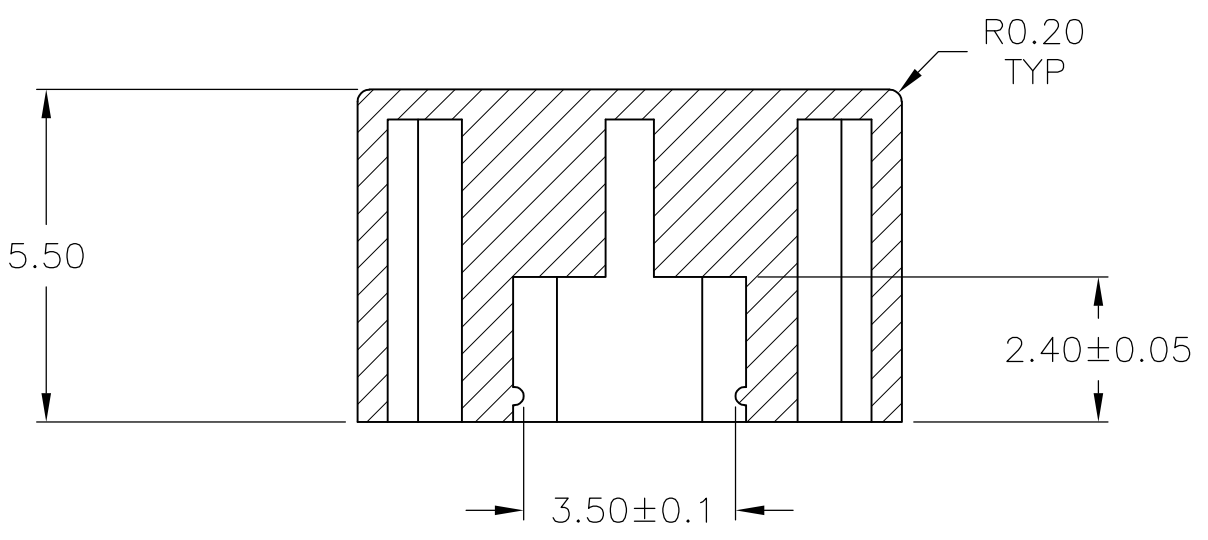

- 1 KEYCAP MUST WITHSTAND WAVE SOLDER PREHEAT TEMPERATURES OF 180°F.
- 2 OBSOLETE PARTS: OBSOLETE CIS STREAMLINING PER D.RENAUD/D.SINISI

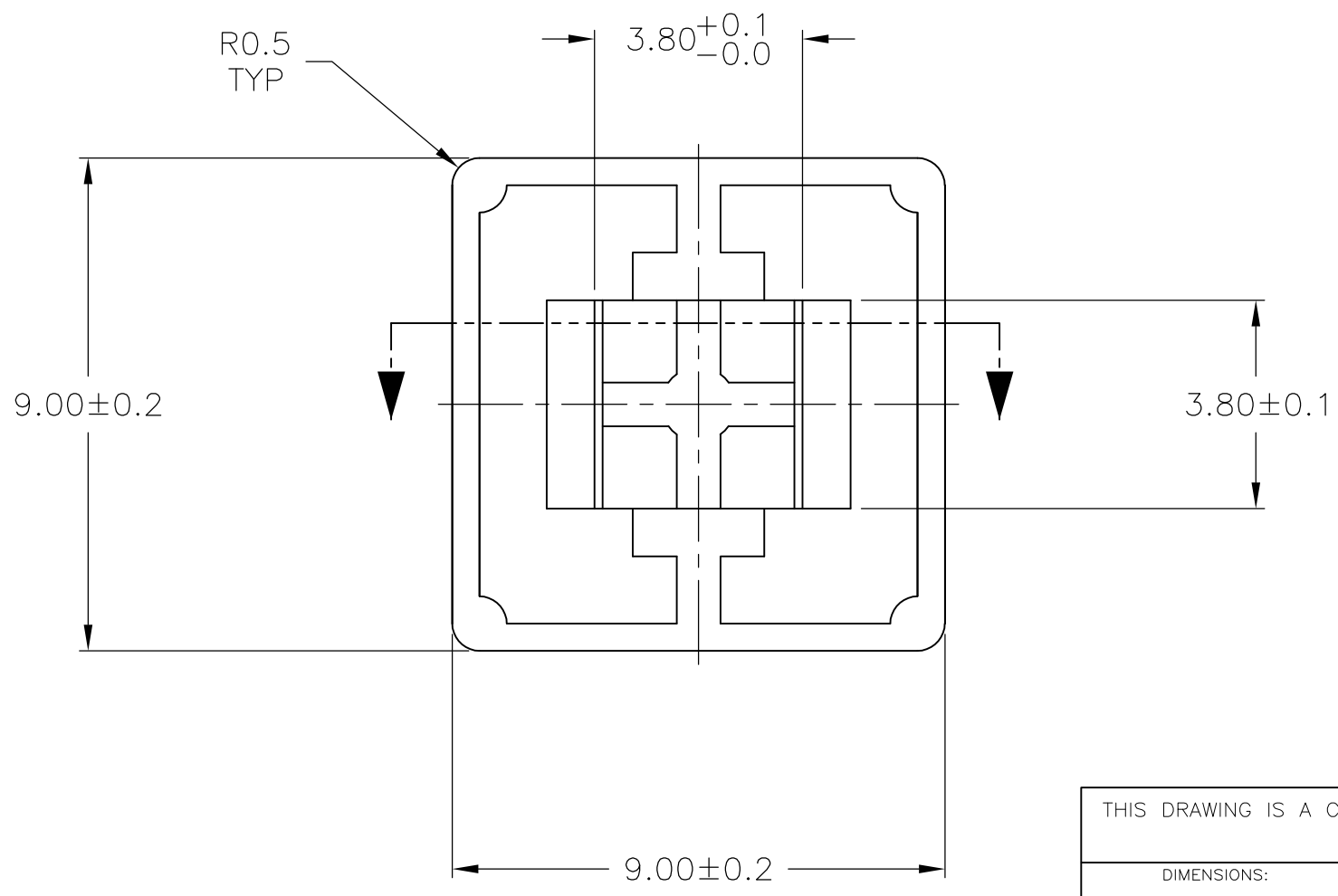

2	OBSOLETE	YELLOW	1571384-7
		RED	1571384-6
		VIOLET	1571384-5
		BLACK	1571384-4
OBSOLETE		BLUE	1571384-3
		ORANGE	1571384-2
		GREEN	1571384-1
	COLOR	TE PART NUMBER	

THIS DRAWING IS A CONTROLLED DOCUMENT.		DWN R BROWN	29SEP03	<b>STE</b> TE Connectivity	
DIMENSIONS: mm		CHK M SARVER	29SEP03		
TOLERANCES UNLESS OTHERWISE SPECIFIED:		APVD M SARVER	29SEP03	NAME KEY CAP	
0 PLC ± -		PRODUCT SPEC		SIZE CAGE CODE DRAWING NO RESTRICTED TO	
1 PLC ± -		APPLICATION SPEC		A3 00779 C-1571384	
2 PLC ± 0.30		WEIGHT 0		SCALE 8:1 SHEET 1 OF 1 REV F4	
3 PLC ± -		CUSTOMER DRAWING			
4 PLC ± -					
ANGLES ± -					
MATERIAL ABS		FINISH -			

单击下面可查看定价，库存，交付和生命周期等信息

[>>TE Connectivity\(泰科\)](#)