

4
DRAWING MADE IN THIRD ANGLE PROJECTION

3

2

1

LOC L DIST 40

© COPYRIGHT 1973 BY AMP INCORPORATED, HARRISBURG, PA. ALL INTERNATIONAL RIGHTS RESERVED. AMP INCORPORATED PRODUCTS COVERED BY U.S. AND FOREIGN PATENTS AND/OR PATENTS PENDING.

THIS INFORMATION IS CONFIDENTIAL AND IS DISCLOSED TO YOU ON CONDITION THAT NO FURTHER DISCLOSURE IS MADE BY YOU TO OTHER THAN AMP PERSONNEL WITHOUT WRITTEN AUTHORIZATION FROM AMP INCORPORATED, HARRISBURG, PA.

THIS PRODUCT DESIGNED AND BUILT BY AMP INCORPORATED. NO LICENSE TO USE THAT DESIGN IN MANUFACTURE, OR TO USE ANY ISSUED OR PENDING PATENTS WHICH ARE INVOLVED, IS IMPLIED.

REVISIONS						
P	F	ZONE	LTR	DESCRIPTION	DATE	APPROVED
			A	REVISED & REDRAWN	8-20-73	H. N...
			B	ADDED .115 DIA. HOLES TYP(4)	2-28-74	JPA
			C	.11 WAS .10, .500 WAS .485, .250 WAS .245, .346 WAS .342, .693 WAS .685, .150/.156 R. WAS .16, ADDED .716 REF.	2/28/74	M.S.
			D	REVISED	10-1-76	M.S.
			E	ADDED TABLE & 861276-2.	10-1-82	B.W.
			F	.441.005 WAS .45 ECH 9591	2/23/83	B.W.
			FI	ADDED - 3 ECH 9638	4/19/83	B.W.
			G	ECO-09-018671	08-09	KH
			H	ECO-10-019774	10-10	DE

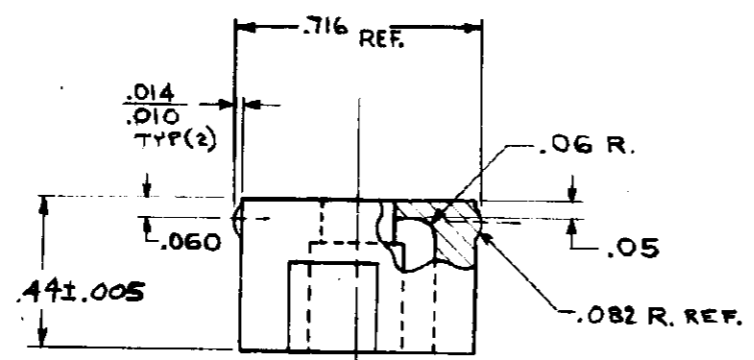

⚠ THESE DIMENSIONS ARE FOR CORING. DO NOT MEASURE

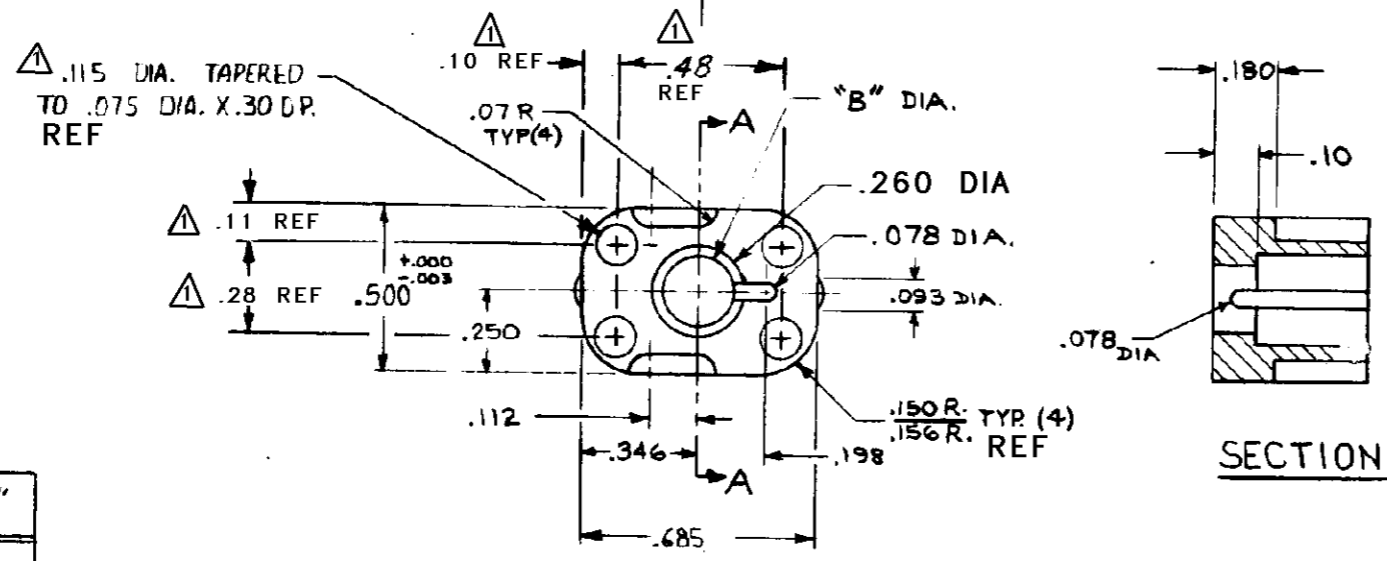

PART NO.	DIM. "B"	
861276-1	.202	
" -2	.234	OBSOLETE
861276-3	.250	OBSOLETE

QTY REQD PER ASSY		CODE IDENT	DWG SIZE	PART NO OR IDENTIFYING NO	NOMENCLATURE OR DESCRIPTION	ITEM NO
		← REVISION OF EACH ASSY NO (WHEN BLANK, USE DWG REVISION)				
		PARTS LIST				
		UNLESS OTHERWISE SPECIFIED DIMENSIONS ARE IN INCHES. TOLERANCES: .00 ± .01 .000 ± .005 ANGLES ±		CONTRACT NO DR L. GEIB 2-1-73 CHK		AMP INCORPORATED Elizabethtown, Pa.
		MATERIAL VALOX 420-SEO 2GG82-1		APPD M. GARDNER 2-5-73 APPO		
		FINISH BLACK		DESIGN APPD		NAME END PLATE LGH
		OTHER APPD		SIZE B		CODE IDENT NO [REDACTED]
		NEXT ASSY		NUMBER 861276		SCALE 2:1
		FINAL ASSY		WT		SHEET 1/1
		QTY REQD		APPLICATION		REV. H

单击下面可查看定价，库存，交付和生命周期等信息

[>>TE Connectivity\(泰科\)](#)