



KMT32B

Magnetic Angle Sensor

SPECIFICATIONS

- AMR Sensor with 180° period
- high accuracy
- high resolution
- for the use at moderate field strengths
- tiny TDFN package
- ROHS & REACH compliant

The KMT32B is a magnetic field sensor based on the anisotropic magneto resistance effect, i.e. it is sensing the **magnetic field direction** independently on the magnetic field strength for applied field strengths $H > 25$ kA/m. The sensor contains two parallel supplied Wheatstone bridges, which enclose a sensitive angle of 45 degrees.

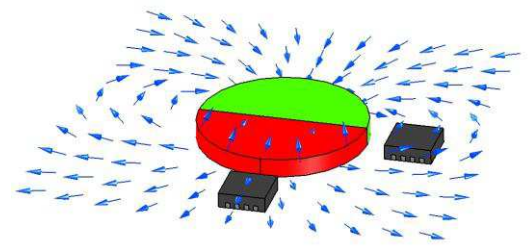
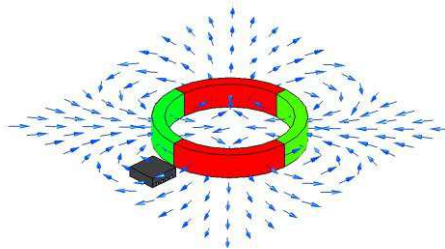
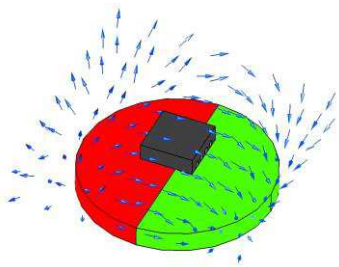

FEATURES

- Contactless angular position, ideal for harsh environments
- Design optimized for linearity
- High accuracy
- Low cost, low power
- Self diagnosis feature
- Attractive SMD packages
- User has complete control over signal evaluation
- Extended operating temperature range (-40 °C to +150 °C, +160°C on request)
- REACH & RoHS compliant (lead free)

A rotating magnetic field in the surface parallel to the chip (x-y plane) will therefore deliver two independent sinusoidal output signals, one following a $\cos(2\alpha)$ and the second following a $\sin(2\alpha)$ function, α being the angle between sensor and field direction (see Figure 2).

The KMT32B magnetic field sensor is suited for high precision angle measurement applications at a regular field strength of $H_0 \geq 25$ kA/m (generated for example with magnet 67.044 from Magnetfabrik Bonn at a distance of 5.2 mm at room temperature). With reduced accuracy, the sensor KMT32B may be used with a field strength of $H_0 \geq 14$ kA/m (at room temperature; be aware of the influence of the earth magnetic field!). Most magnets show a decreasing field strength with temperature while the magnetic field direction is unchanged.

APPLICATIONS

- Absolute and incremental angle measurement
- Automotive (steering angle, torque)
- Robotics
- Camera positioning
- Potentiometer replacement
- Position measurement in medical applications
- Motor motion control

CHARACTERISTIC VALUES

Parameter	Symbol	Condition	Min	Typ	Max	Unit
A. Operating Limits						
Max. supply voltage	$V_{CC,max}$				10	V
Max. current (single bridge)	$I_{CC,max}$				4	mA
Operating temperature	T_{op}		-40		+150	°C
Storage temperature	T_{st}		-40		+150	°C
B. Sensor Specifications (T=25 °C)						
Supply voltage	V_{CC}			5		V
Resistance (single bridge)	R_b		2400	3000	3600	Ω
Output signal amplitude	V_{PEAK}	Condition A, B	9	11	13	mV/V
Offset voltage	V_{OFF}	Condition A, B	-1	0	+1	mV/V
Angular inaccuracy	$\Delta\alpha$	Condition A, B		0.05	0.2	deg
Angular hysteresis	$\Delta\alpha_H$	Condition A, B			0.1	deg
C. Sensor Specifications						
TC of amplitude	TCSV	Condition A, C		-0.35		%/K
TC of resistance	TCBR	Condition A, C		+0.35		%/K
TC of offset	TCVoff	Condition A, C	-4	0	+4	$\mu V/V/K$

Stress above one or more of the limiting values may cause permanent damage to the device. Exposure to limiting values for extended periods may affect device reliability.

MEASUREMENT CONDITIONS

Parameter	Symbol	Unit	Condition
Condition A: Set Up Conditions			
Ambient temperature	T	°C	T = 25 °C (unless otherwise noted)
Supply voltage	V_{CC}	V	$V_{CC} = 5 V$
Applied magnetic field	H	kA/m	H = 25 kA/m

Condition B: Sensor Specifications (360° turn , Vo_{max}>0, Vo_{min}<0)			
Output signal amplitude	V _{PEAK}	mV/V	$V_{PEAK} = (V_{Omax} - V_{Omin})/2/V_{CC}$
Offset voltage	V _{OFF}	mV/V	$V_{OFF} = (V_{Omax} + V_{Omin})/2/V_{CC}$
Angular inaccuracy	Δα	deg	Δα = MAX α ₀ -α ; max. angular difference between actual field angle α ₀ and measured angle α due to deviations from ideal sinusoidal characteristics, calculated from the third and fifth harmonics of the Fourier spectrum; offset voltage error contributions not included
Angular hysteresis	ΔαH	deg	ΔαH = α _{left turn} - α _{right turn} angular difference between left and right turn

MEASUREMENT CONDITIONS

Parameter	Symbol	Unit	Condition
Condition C: Sensor Specifications (-25°C, +125°C)			
Ambient temperatures	T	°C	T ₁ = -25 °C, T ₀ = +25 °C, T ₂ = +125 °C
TC of amplitude	TCSV	%/K	$TCV = \frac{1}{(T_2 - T_1)} \cdot \frac{\frac{\Delta Vn}{V_{cc}}(T_2) - \frac{\Delta Vn}{V_{cc}}(T_1)}{\frac{\Delta Vn}{V_{cc}}(T_1)} \cdot 100\%$
TC of resistance	TCBR	%/K	$TCR = \frac{1}{(T_2 - T_1)} \cdot \frac{R(T_2) - R(T_1)}{R(T_1)} \cdot 100\%$
TC of offset	TCVoff	(μV/V)/K	$TCV_{off} = \frac{V_{off}(T_2) - V_{off}(T_1)}{(T_2 - T_1)}$

BLOCK DIAGRAM

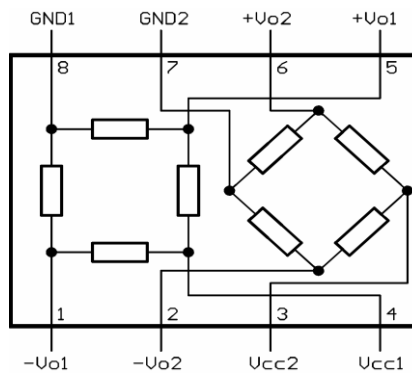

Figure 1: Circuit Diagram

KMT32B

Magnetic Angle Sensor

TYPICAL PERFORMANCE CURVES

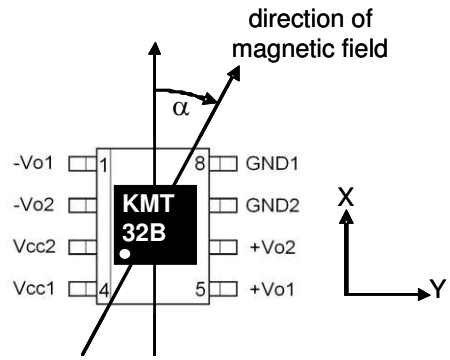
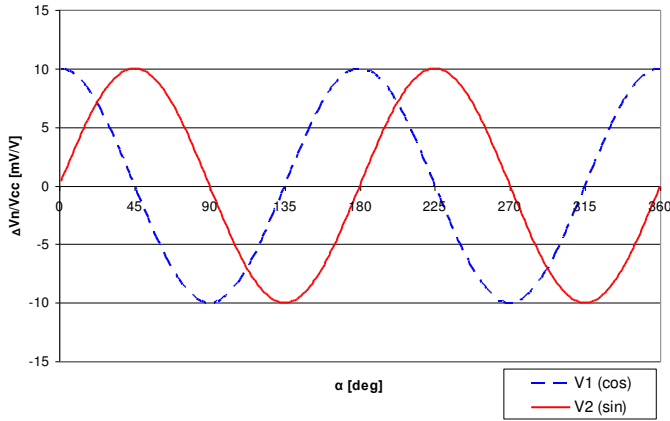
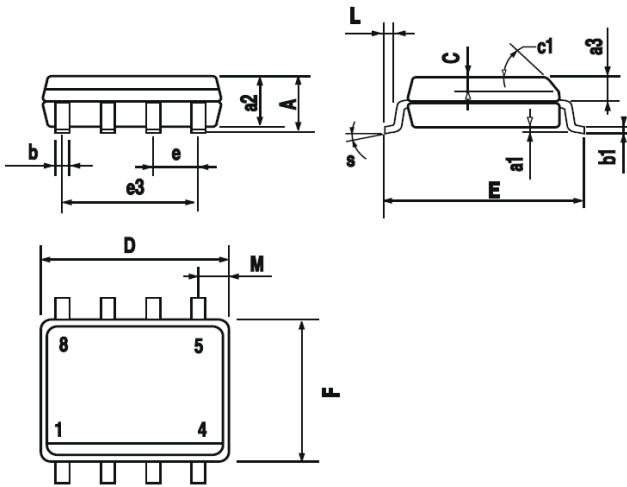

Figure 2: Characteristic curves for KMT32B (SO8, TDFN)

PACKAGES

SO8



DIM.	mm			inch		
	MIN.	TYP.	MAX.	MIN.	TYP.	MAX.
A			1.75			0.069
a1	0.1		0.25	0.004		0.010
a2			1.65			0.065
a3	0.65		0.85	0.026		0.033
b	0.35		0.48	0.014		0.019
b1	0.19		0.25	0.007		0.010
C	0.25		0.5	0.010		0.020
c1	45° (typ.)					
D (1)	4.8		5.0	0.189		0.197
E	5.8		6.2	0.228		0.244
e		1.27			0.050	
e3		3.81			0.150	
F (1)	3.8		4.0	0.15		0.157
L	0.4		1.27	0.016		0.050
M			0.6			0.024
S	8° (max.)					

KMT32B

Magnetic Angle Sensor

TDFN 2.5*2.5

unit: mm

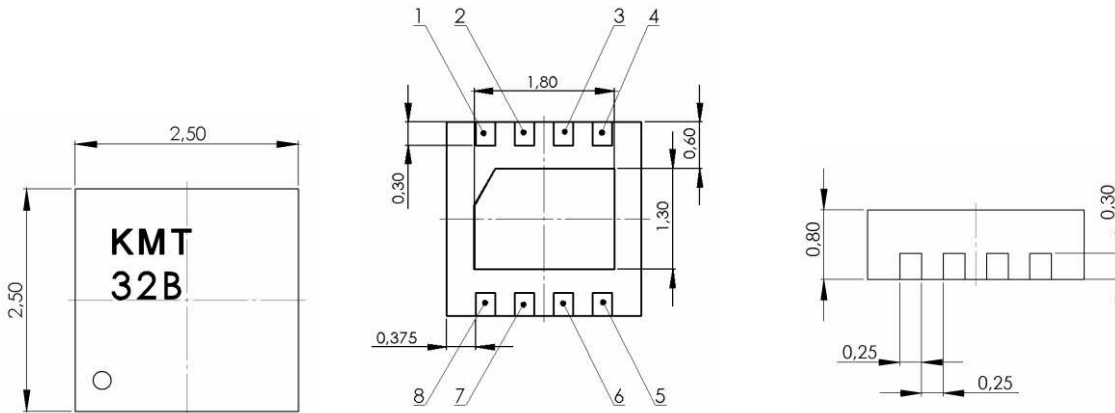

RECOMMENDED SOLDER PAD LAYOUT FOR TDFN

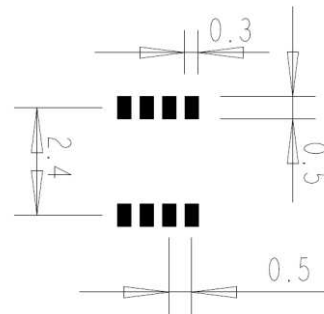

PIN ASSIGNMENT (SO8, TDFN)

Pin (SO8)	Pin (TDFN)	Symbol	Function
1	7	$-V_{o1}$	negative output bridge 1
2	8	$-V_{o2}$	negative output bridge 2
3	1	V_{cc2}	positive supply voltage bridge 2
4	2	V_{cc1}	positive supply voltage bridge 1
5	3	$+V_{o1}$	positive output bridge 1
6	4	$+V_{o2}$	positive output bridge 2
7	5	GND_2	negative supply voltage bridge 2
8	6	GND_1	negative supply voltage bridge 1

SOLDER PROFILE

Recommended solder reflow process according to IPC/JEDEC J-STD-020D (Pb-Free Process)

KMT32B

Magnetic Angle Sensor

TAPE AND REEL PACKAGING INFORMATION

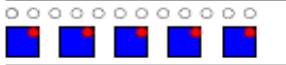
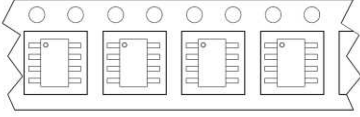
Description	Reel size	Units/reel	Pin 1 orientation	Note
KMT32B/TD	7"	3,000	Top-right of sprocket hole side	
KMT32B/SO	13"	2,500	Top-left of sprocket hole side	

ORDERING CODE

Device	Package	MOQ	Part Number
KMT 32B/SO	SO-8	1 reel	G-MRCO-015
KMT 32B/TD	TDFN 2.5 x 2.5	1 reel	G-MRCO-016

ORDERING INFORMATION

NORTH AMERICA

Measurement Specialties, Inc.,
a TE Connectivity Company
Phone: +1-800-522-6752
Email: customer care.hmpt@te.com

EUROPE

MEAS Deutschland GmbH (Europe)
a TE Connectivity Company
Phone: +49-800-440-5100
Email: customer care.dtm@te.com

ASIA

Measurement Specialties (China), Ltd.,
a TE Connectivity Company
Phone: +86-400-820-6015
Email: customer care.shzn@te.com

TE.com/sensorsolutions

Measurement Specialties, Inc., a TE Connectivity company.

Measurement Specialties, TE Connectivity, TE Connectivity (logo) and EVERY CONNECTION COUNTS are trademarks. All other logos, products and/or company names referred to herein might be trademarks of their respective owners.

The information given herein, including drawings, illustrations and schematics which are intended for illustration purposes only, is believed to be reliable. However, TE Connectivity makes no warranties as to its accuracy or completeness and disclaims any liability in connection with its use. TE Connectivity's obligations shall only be as set forth in TE Connectivity's Standard Terms and Conditions of Sale for this product and in no case will TE Connectivity be liable for any incidental, indirect or consequential damages arising out of the sale, resale, use or misuse of the product. Users of TE Connectivity products should make their own evaluation to determine the suitability of each such product for the specific application.

© 2015 TE Connectivity Ltd. family of companies All Rights Reserved.

单击下面可查看定价，库存，交付和生命周期等信息

[>>TE Connectivity\(泰科\)](#)