

THIS DRAWING IS UNPUBLISHED.

RELEASED FOR PUBLICATION

20

LOC
ES

DIST

REVISIONS

© COPYRIGHT 20 ALL RIGHTS RESERVED.

P	LTR	DESCRIPTION	DATE	DWN	APVD
	4	REVISED	15OCT2013	R.W	W.H

AS SHOWN: 2199075-2

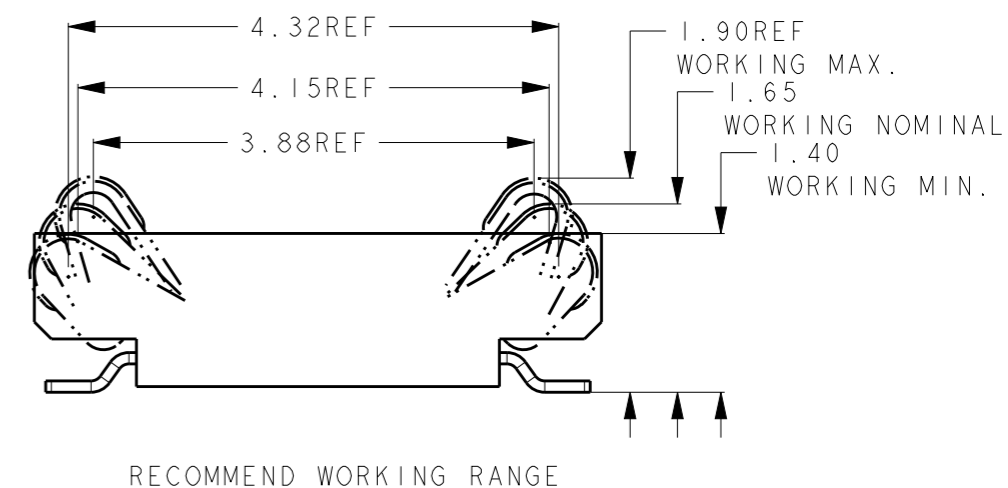
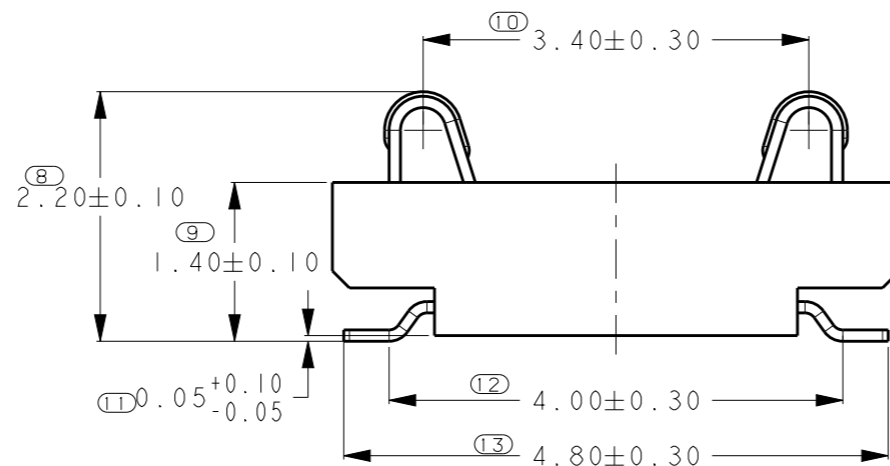
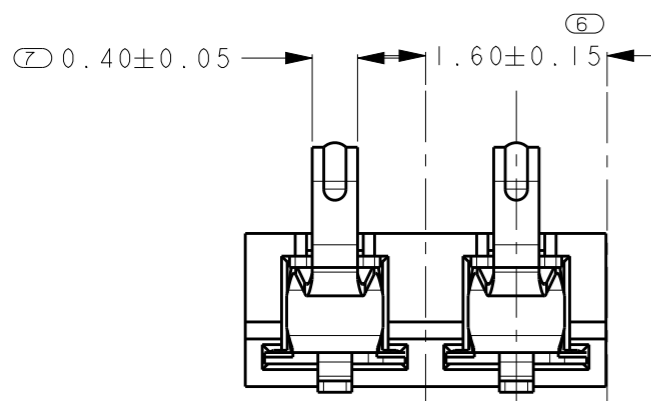
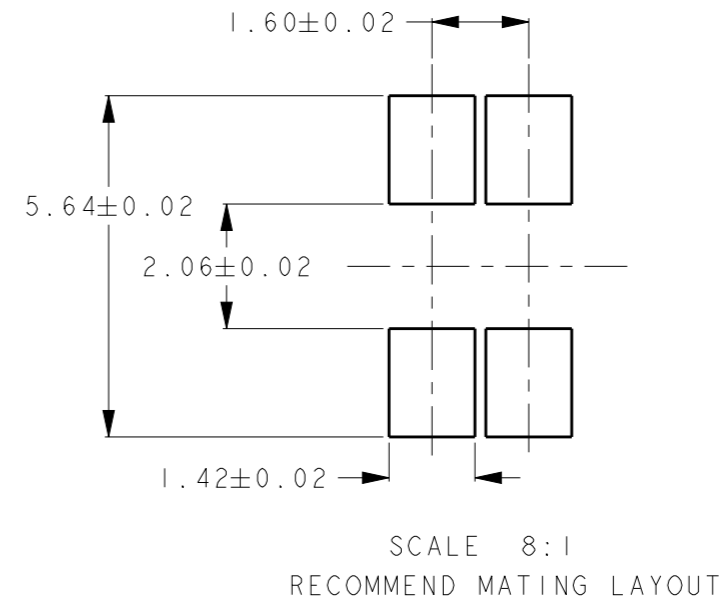
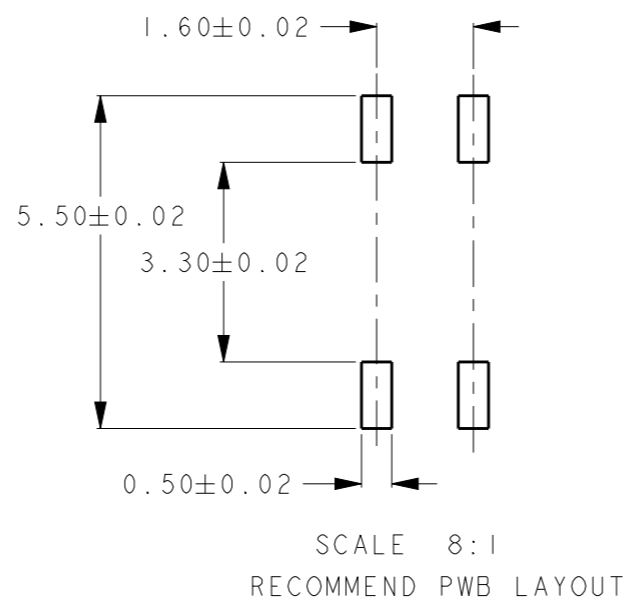
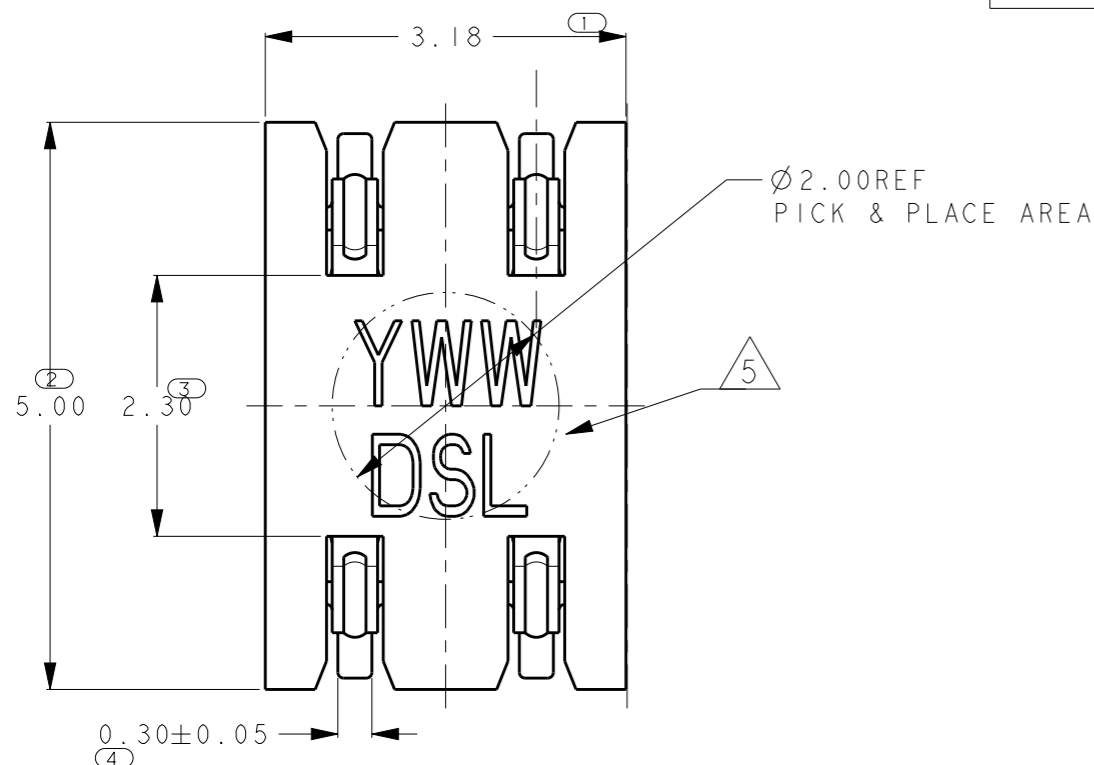

- NOTES:
- 1 MATERIAL
TERMINAL : COPPER ALLOY, THICKNESS 0.10mm.
HOUSING : HIGH TEMPERATURE THERMO PLASTIC
UL94V-0 BLACK
 - 2 FINISH
TERMINAL : 0.10-0.2 um GOLD PLATING ON CONTACT AREA,
1.25 um MIN. NICKLE UNDER PLATING,
GOLD FLASH PLATING ON SOLDERING AREA.
 - 3 COPLANARITY : 0.08 MAX. AMANG ALL SOLDER TAILS.
 - 4 PACKAGING : TAPE & REEL.
 - 5 DATE CODE : "YWWDSL"
YWW = PRODUCTION DATE (YEAR, WEEK, DAY).
S = SHIFT (D=DYA, N=NIGHT); L = LINE NUMBER.

THIS DRAWING IS A CONTROLLED DOCUMENT.		DWN	02APR2013	STE TE Connectivity
		CHK	RAY WANG 02APR2013	
		APVD	WENKE HE	
		APVD	STEVEN YAO	NAME
		PRODUCT SPEC	108-115039	ONE PIECE BtoB CONNECTOR 4 PINS, 1.6MM PITCH, H1.65, TWO ROWS
		APPLICATION SPEC	-	RESTRICTED TO
		WEIGHT	-g	SIZE
		CUSTOMER DRAWING	A300779	CAGE CODE
			G-2199075	DRAWING NO
			SCALE 20:1	SHEET 1 OF 2
				REV 4

4

3

2

1

THIS DRAWING IS UNPUBLISHED. RELEASED FOR PUBLICATION 20
 © COPYRIGHT 20 ALL RIGHTS RESERVED.

LOC	DIST	REVISIONS			
P	LTR	DESCRIPTION	DATE	DWN	APVD
ES		SEE SHEET 1	-	-	-

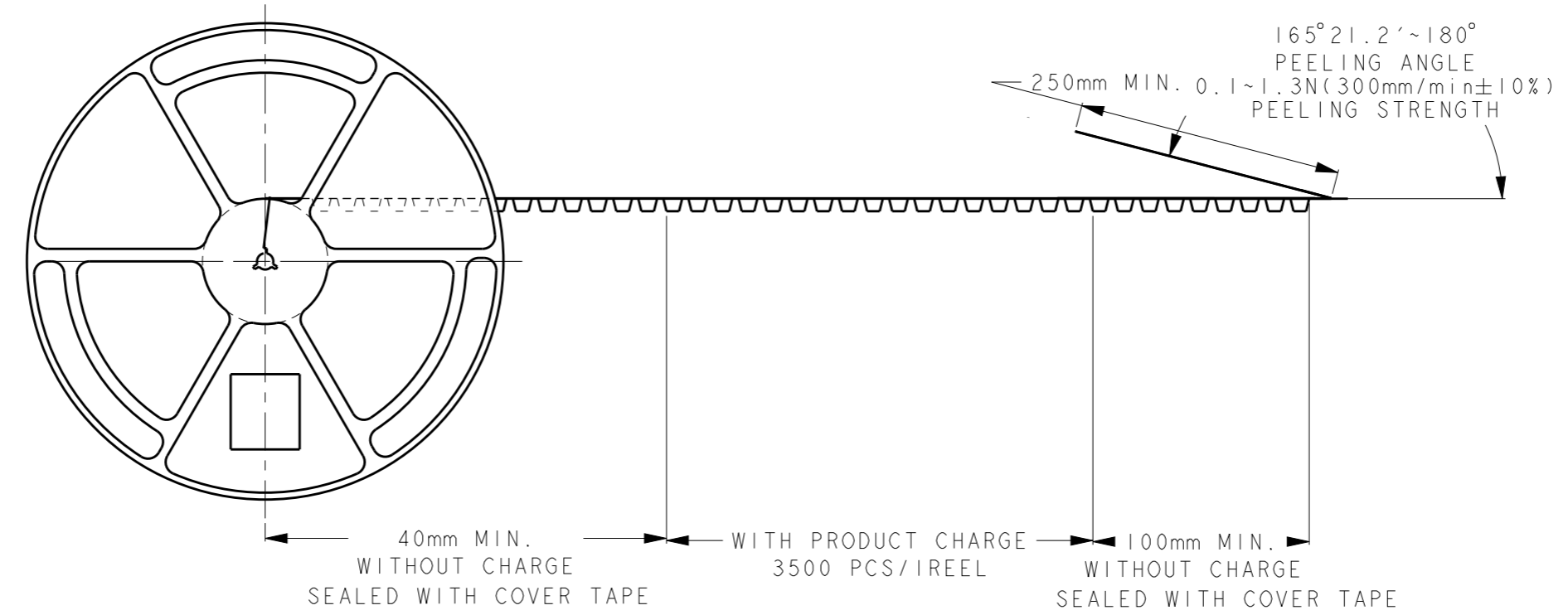
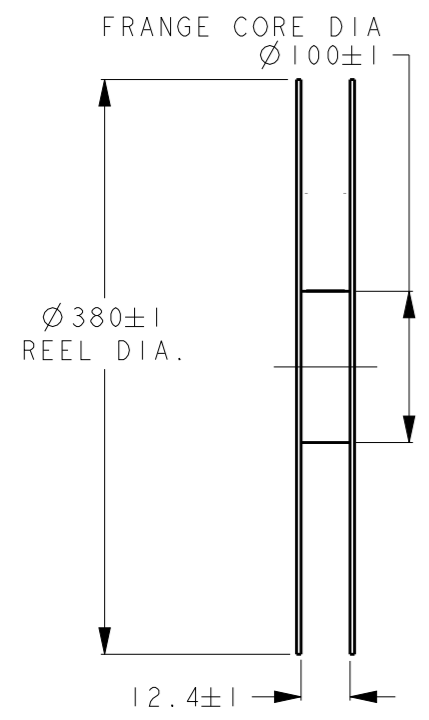
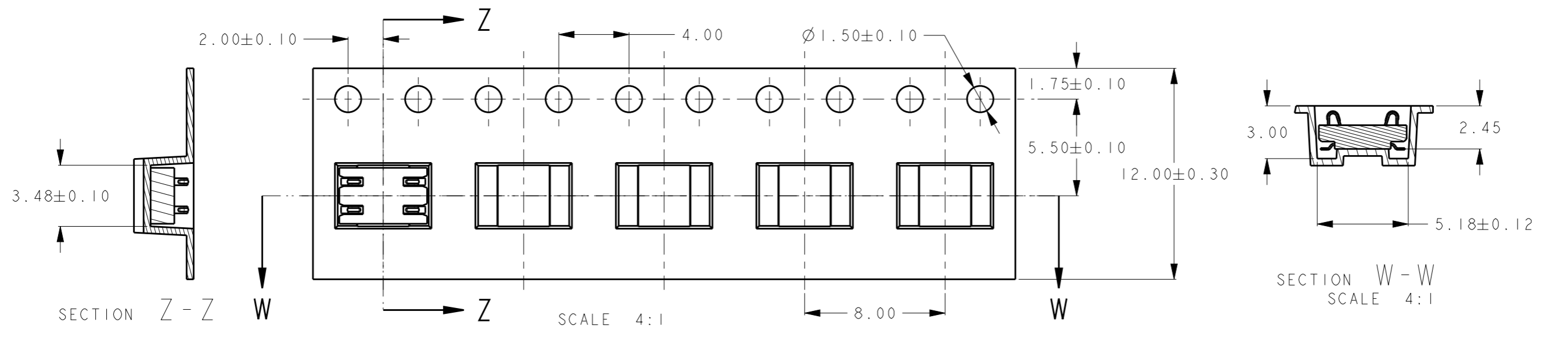

NOTES:
 1. MATERIAL: P.S CLEAR, 0.4MM THICKNESS.
 2. QUANTITY PER REEL: 3500 PIECES.

THIS DRAWING IS A CONTROLLED DOCUMENT.		DWN	02APR2013	STE TE Connectivity
		CHK	02APR2013	
		APVD	02APR2013	
DIMENSIONS: mm		STEVEN YAO		NAME
TOLERANCES UNLESS OTHERWISE SPECIFIED: ±0.20		PRODUCT SPEC		ONE PIECE BtoB CONNECTOR
0-PLC ±		108-115039		4 PINS, 1.6MM PITCH, HI.65 TWO ROWS
1-PLC ±		APPLICATION SPEC		SIZE
2-PLC ±				CAGE CODE
3-PLC ±		WEIGHT		DRAWING NO
4-PLC ±		CUSTOMER DRAWING		RESTRICTED TO
ANGLES ±5°				A300779
MATERIAL				©-2199075
FINISH				SCALE 20:1
				SHEET 2 OF 2
				REV 4

单击下面可查看定价，库存，交付和生命周期等信息

[>>TE Connectivity\(泰科\)](#)