

THIS DRAWING IS UNPUBLISHED. RELEASED FOR PUBLICATION
 © COPYRIGHT - By - ALL RIGHTS RESERVED.

REVISIONS					
P	LTR	DESCRIPTION	DATE	DWN	APVD
C2		ADDED ALUMINIUM WIRE RANGE	05NOV19	MB	PKS

- 1 CONTINUOUS STRIP ON REELS WITH TERMINALS LOCATED ON 8.38 ± 0.08 [$.330 \pm .003$] CENTERS.
- 2 SLOT TERMINATES EITHER A SINGLE OR DOUBLE MAGNET WIRES OF THE SAME TYPE AND SIZE, COPPER RANGE: 0.36–0.57mm [#27–#23] AWG. ALUMINIUM RANGE: 0.51–0.64mm [#24–#22] AWG. ALUMINIUM WIRE RANGE APPLIES FOR POST TIN PLATED PARTS ONLY.
- 3 AFTER INSERTION INTO PLASTIC HOLDER TAB PORTION MUST BE BENT OVER 45° TO 90° OR POTTED-IN TO PREVENT PULL-OUT WHEN MATING RECEPTACLE IS DISCONNECTED.
- 4 CAVITY SPECIFICATION TO BE MODIFIED TO ACCEPT WIDER TAB TRANSITION.

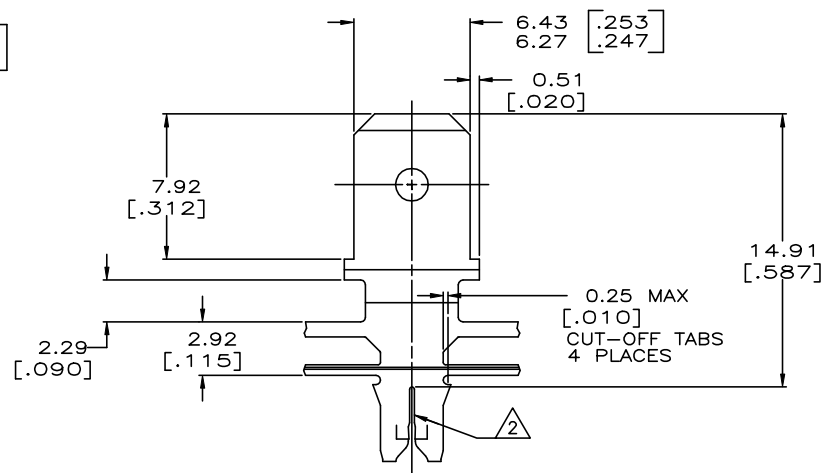
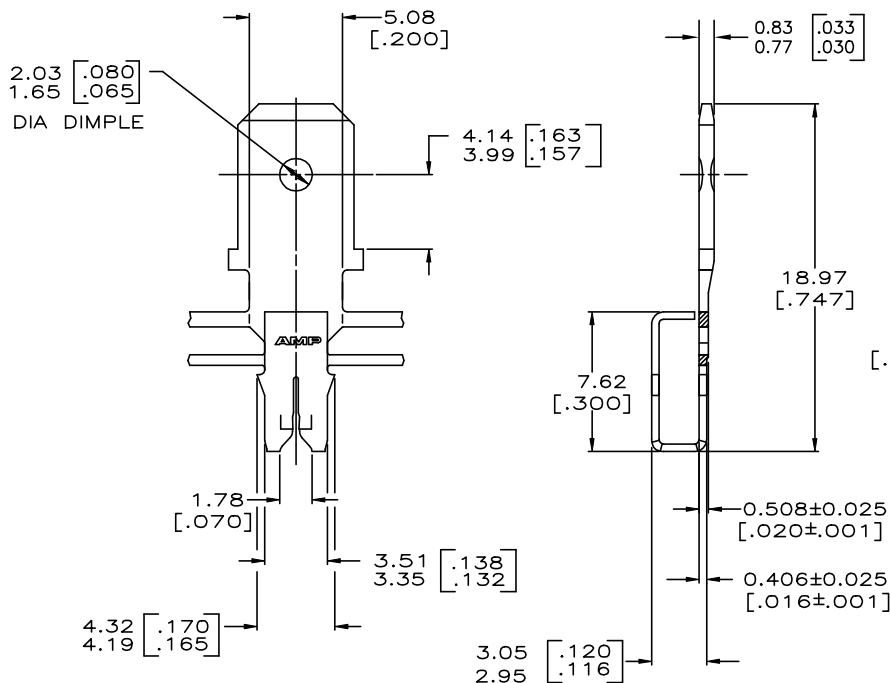

63920-1
PART NUMBER

THIS DRAWING IS A CONTROLLED DOCUMENT.		DWN MICHAEL S. FEHER 10JUL98	TE Connectivity	
DIMENSIONS: INCHES		CHK RICHARD GRZYBOWSKI 11JUL98	APVD GARY PORTA 12JUL98	
TOLERANCES UNLESS OTHERWISE SPECIFIED:		NAME TAB, 6.35[.250] FASTON™ MAG-MATE™		
0 PLC ± -	1 PLC ± -	PRODUCT SPEC 108-2012		
2 PLC ± 0.25[.010]	3 PLC ± -	APPLICATION SPEC 114-2046 4		
4 PLC ± -	ANGLES ± -	SIZE A2	CAGE CODE 00779	DRAWING NO C=63920
MATERIAL BRASS	FINISH TIN PLATE	WEIGHT -	RESTRICTED TO -	SCALE 5:1
CUSTOMER DRAWING		SHEET 1 of 1	REV C2	

单击下面可查看定价，库存，交付和生命周期等信息

[>>TE Connectivity\(泰科\)](#)