

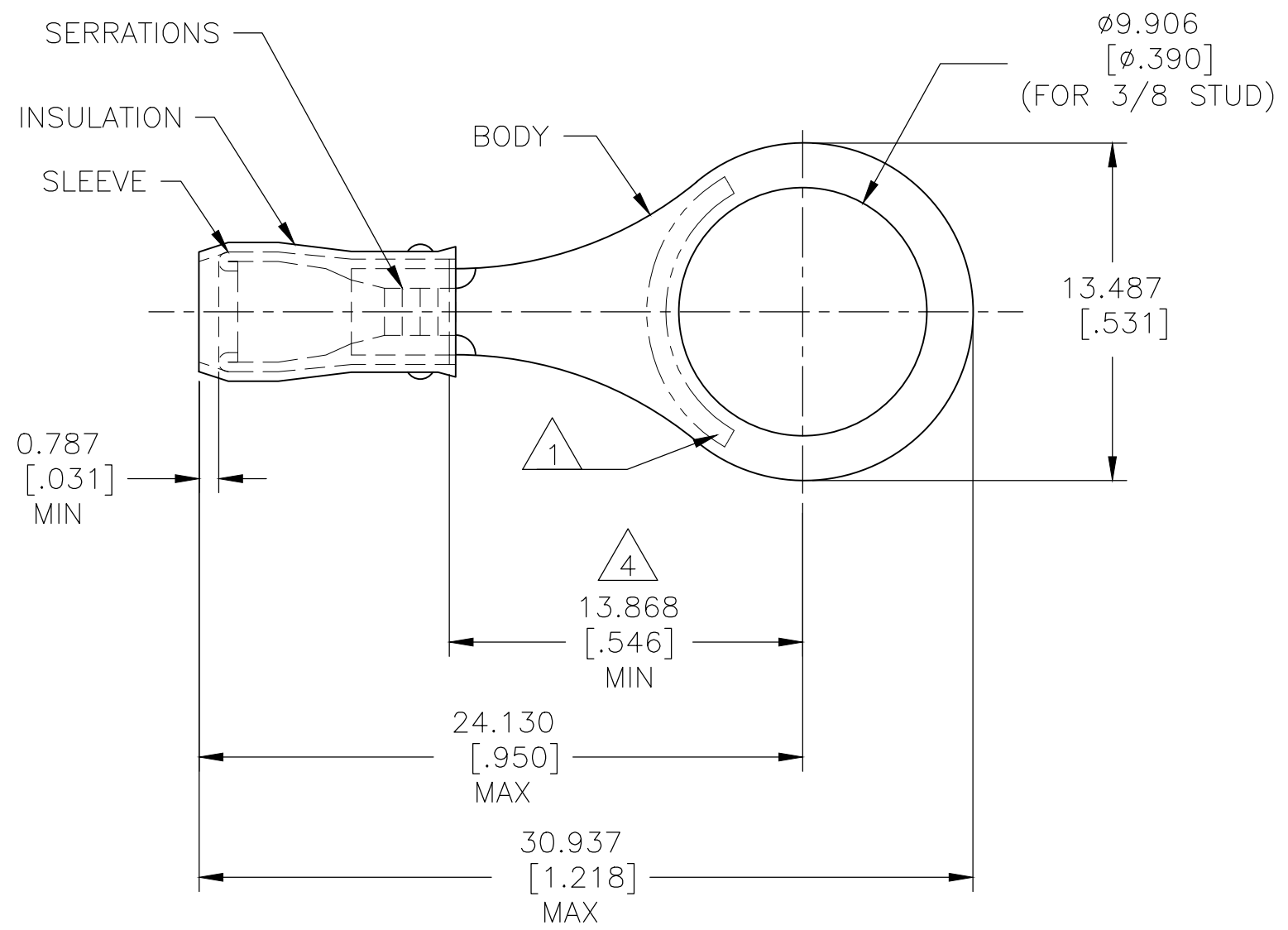

THIS DRAWING IS UNPUBLISHED. RELEASED FOR PUBLICATION
 © COPYRIGHT - By - ALL RIGHTS RESERVED.

REVISIONS					
P	LTR	DESCRIPTION	DATE	DWN	APVD
	Y1	REVISED PER ECO-17-007400	19DEC2017	RS	DR
	Y2	REVISED PER ECO-19-007720	21MAY2020	KR	DR

AMP WIRE RANGE	 E13288 Listed	 LR7189 Certified
22-16 AWG SOLID OR STRANDED	22-16 AWG STRANDED	22-16 AWG SOLID OR STRANDED

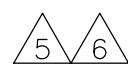
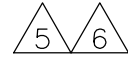
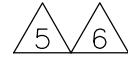

- 1 STAMP AMP 22-18* LOCATE APPROX AS SHOWN 22-16 TERMINALS ARE STAMPED 22-18 IN ACCORDANCE WITH MILITARY SPEC SAE AS7928 COMMERCIAL WIRE RANGE IS 22-16.
- 2 WIRE INSUL : $\phi 2.032[\phi .080]-\phi 3.175[\phi .125]$.
- 3 BODY MATERIAL THK: $0.787\pm 0.051[.031\pm .002]$.
- 4 APPLIES FROM EDGE OF METAL WIRE BARREL TO CENTER OF STUD HOLE.
- 5 UL LISTED
- 6 CSA CERTIFIED

 	MS 25036-105 CLASS 2	5000	ON TAPE	2-320573-4
 	MS 25036-105 CLASS 1 & 2	1000	LOOSE PIECE	320573
	MILITARY P/N AND CLASS	QUANTITY	PACKAGE TYPE	PART NO

**AMP INCORPORATED
CUSTOMER SERVICE SYSTEMS**

FOR ADDITIONAL PRODUCT INFORMATION OR COPIES OF DRAWINGS AND TECHNICAL DOCUMENTS
 PRODUCT INFORMATION CENTER
 1-800-522-6752

FOR APPLICATION TOOLING ASSISTANCE CENTER
 TOOLING INFORMATION
 1-800-722-1111

FOR ORDER ENTRY
 1-800-526-5142

MAX RECOMMENDED OPERATING TEMPERATURE:
 105°C[221°F] MAX

VOLTAGE RATING:
 300 V MAX

CIRCULAR MIL AREA:
 0.26-1.65mm (509-3,260) CIR MILS
 SOLID OR STRANDED

THIS DRAWING IS A CONTROLLED DOCUMENT.

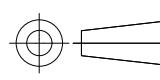
DIMENSIONS: mm [INCHES]	TOLERANCES UNLESS OTHERWISE SPECIFIED:
	0 PLC ± - 1 PLC ± - 2 PLC ± - 3 PLC ± 0.127[.005] 4 PLC ± - ANGLES ± -

MATERIAL
 BODY & SLEEVE
 COPPER PER ASTM B-152
 INSULATION: NYLON

FINISH
 BODY & SLEEVE
 TIN PLATE PER ASTM B 545
 INSULATION: COLOR-RED

DWN DK SCHRUM 9/93
 CHK RE HERSEY 9/93
 APVD ML ELLIS 9/93

STE TE Connectivity

NAME
 TERMINAL, RING TONGUE,
 PIDG™, WIRE SIZE, 22-16 AWG

PRODUCT SPEC
 UL 486 A-B 

APPLICATION SPEC
 114-2157

WEIGHT -

SIZE A3 CAGE CODE 00779 DRAWING NO C-320573 RESTRICTED TO -

CUSTOMER DRAWING SCALE 4:1 SHEET 1 OF 2 REV Y2

THIS DRAWING IS UNPUBLISHED. RELEASED FOR PUBLICATION
 © COPYRIGHT - By - ALL RIGHTS RESERVED.

REVISIONS					
P	LTR	DESCRIPTION	DATE	DWN	APVD
-	-	SEE SHEET 1	-	-	-

AMP WIRE RANGE	 LR7189 Certified
SEE TABLE STRANDED	WIRE SIZE PER TABLE STRANDED

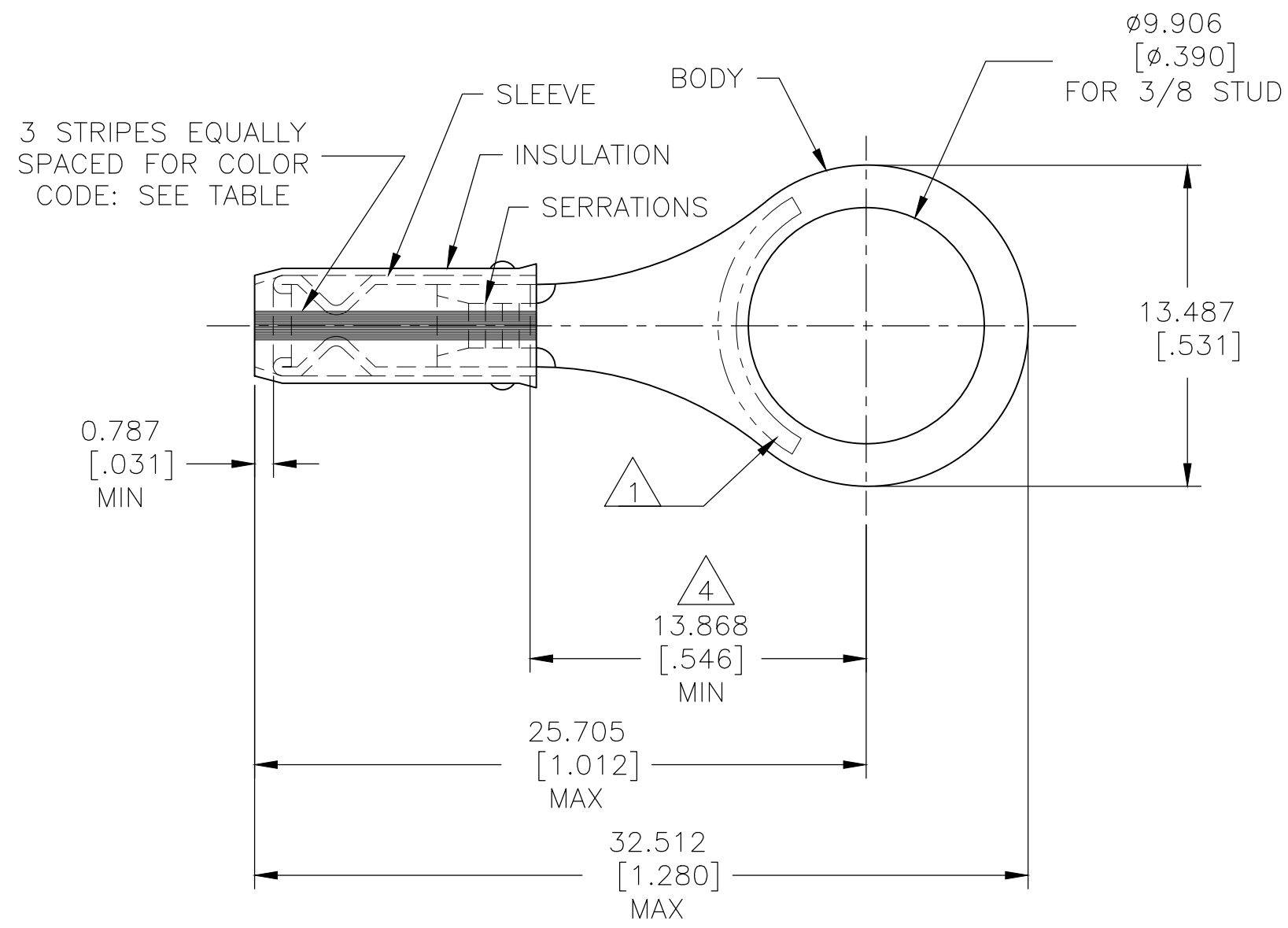

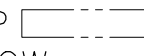
- 1 STAMP AMP  LOCATE APPROX AS SHOWN SEE TABLE BELOW.
- 2 WIRE INSULATION : $\phi 0.965-2.794[\phi 0.038-.110]$ FOR 22 AWG.
 $\phi 1.168-2.794[\phi 0.046-.110]$ FOR 20 AWG.
 $\phi 1.422-2.794[\phi 0.056-.110]$ FOR 18 AWG.
- 3 BODY MATERIAL THK: $0.787 \pm 0.051[.031 \pm .002]$.
- 4 APPLIES FROM EDGE OF METAL WIRE BARREL TO CENTER OF STUD HOLE.
- 5 CSA CERTIFIED

5	M7928/1-36 CLASS 1 & 2	WHITE	18*	18	1000	LOOSE PIECE	2-320573-3	
5	M7928/1-27 CLASS 1 & 2	RED	20*	20			2-320573-2	
5	M7928/1-18 CLASS 1 & 2	GREEN	22*	22			2-320573-1	
	MILITARY P/N AND CLASS	STRIPE COLOR	1	STAMPING	WIRE SIZE	QTY	PACKAGE TYPE	PART NO

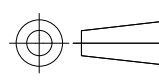
AMP INCORPORATED CUSTOMER SERVICE SYSTEMS		MAX RECOMMENDED OPERATING TEMPERATURE: 105°C[221°F] MAX	THIS DRAWING IS A CONTROLLED DOCUMENT.		DWN DK SCHRUM 9/93	 TE Connectivity			
FOR ADDITIONAL PRODUCT INFORMATION OR COPIES OF DRAWINGS AND TECHNICAL DOCUMENTS	PRODUCT INFORMATION CENTER 1-800-522-6752	VOLTAGE RATING: 300 V MAX	DIMENSIONS: mm [INCHES]	TOLERANCES UNLESS OTHERWISE SPECIFIED:	CHK RE HERSEY 9/93				NAME
FOR APPLICATION TOOLING INFORMATION	TOOLING ASSISTANCE CENTER 1-800-722-1111	WIRE RANGE:		0 PLC ± -	APVD ML ELLIS 9/93	TERMINAL, RING TONGUE, I.R., PIDG™, WIRE SIZE, 22,20 & 18 AWG			
FOR ORDER ENTRY	1-800-526-5142	22 0.38mm² [754] 20 0.60mm² [1,186] 18 0.96mm² [1,900] STRANDED		MATERIAL BODY & SLEEVE COPPER PER ASTM B-152 INSULATION: NYLON	1 PLC ± - 2 PLC ± - 3 PLC ± 0.127[.005] 4 PLC ± - ANGLES ± -	PRODUCT SPEC -	SIZE	CAGE CODE	DRAWING NO
			FINISH BODY & SLEEVE TIN PLATE PER ASTM B 545 INSULATION: COLOR-RED	114-2157	WEIGHT -	A3	00779	C-320573	-
CUSTOMER DRAWING					SCALE 4:1	SHEET 2 OF 2	REV Y2		

单击下面可查看定价，库存，交付和生命周期等信息

[>>TE Connectivity\(泰科\)](#)