

THIS DRAWING IS UNPUBLISHED. RELEASED FOR PUBLICATION  
 © COPYRIGHT - By - ALL RIGHTS RESERVED.

LOC		DIST		REVISIONS			
P	LTR	DESCRIPTION		DATE	DWN	APVD	
BD	36	G1	REVISED PER ECO-13-008672		31AUG2013	KH	DR

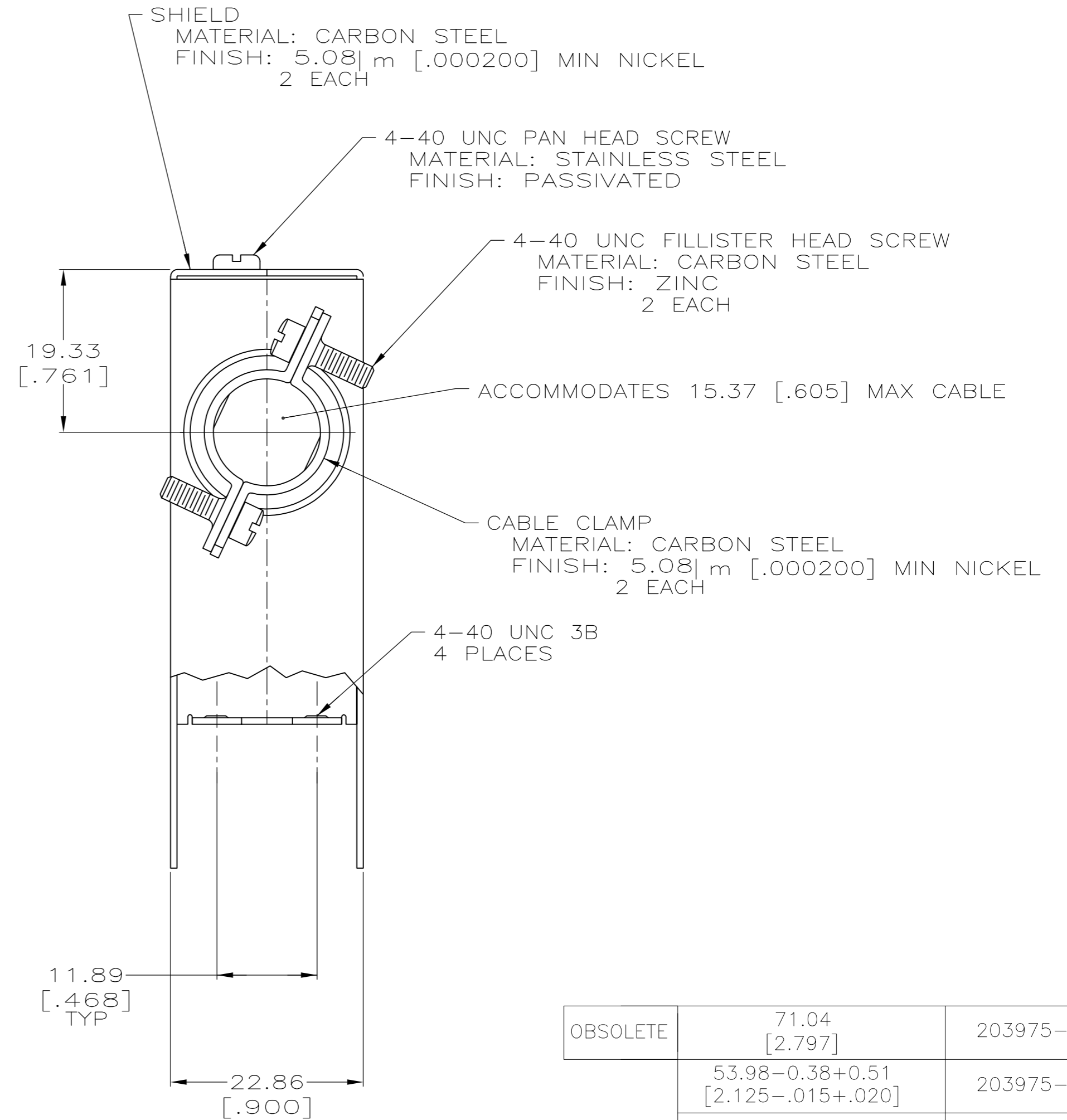
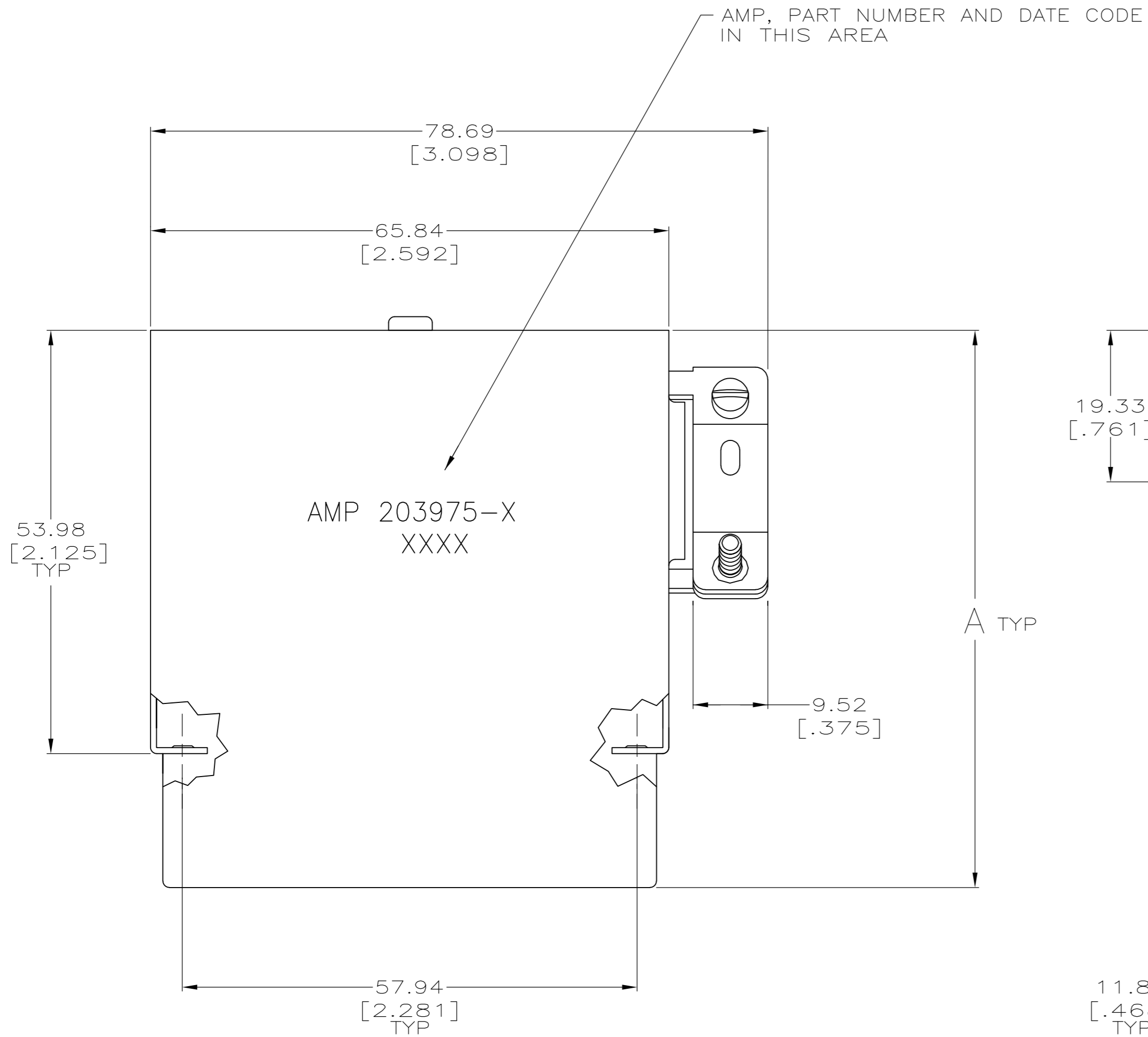

OBSOLETE	71.04 [2.797]	203975-2
	53.98-0.38+0.51 [2.125-.015+.020]	203975-1
	A	PART NUMBER

THIS DRAWING IS A CONTROLLED DOCUMENT.		DWN	C.DORWART	28 SEP 95	 TE Connectivity
DIMENSIONS: mm [INCHES]		CHK	R.STONE	02 OCT 95	
TOLERANCES UNLESS OTHERWISE SPECIFIED:		APVD	G.STEINHAUER	04 OCT 95	
0 PLC ± - 1 PLC ± - 2 PLC ± 0.38 [.015] 3 PLC ± - 4 PLC ± - ANGLES ± -		PRODUCT SPEC	NAME		
MATERIAL SEE CALLOUTS		FINISH SEE CALLOUTS	APPLICATION SPEC		SIZE
		WEIGHT	-		CAGE CODE
		CUSTOMER DRAWING	A2 00779		DRAWING NO
		SCALE	2:1		RESTRICTED TO
		SHEET	1 OF 1		REV
		REV	G1		

单击下面可查看定价，库存，交付和生命周期等信息

[>>TE Connectivity\(泰科\)](#)