

THIS DRAWING IS UNPUBLISHED. RELEASED FOR PUBLICATION
© COPYRIGHT BY TYCO ELECTRONICS CORPORATION. ALL RIGHTS RESERVED.

LOC	DIST	REVISIONS			
P	LTR	DESCRIPTION	DATE	DWN	APVD
AF	50				
	G	REVISED PER 0G3A-0691-02	19DEC02	MF	GP
	G1	REVISED PER ECO-09-021826	05JAN10	KK	AEG

1 CONTINUOUS STRIP ON REELS WITH TERMINALS
LOCATED ON .350 CENTERS.

2 P/N 61769-3 TO BE PACKAGED ON PLASTIC
REELS, 25,000 PER REEL.

3 CRIMP WIDTH: .090 F TYPE
CRIMP HEIGHT: (±.002) = (TOTAL CMA + 8300) / 145,800
FOR APPLICATOR INFORMATION CALL: 1-800-722-1111
FOR PRODUCT INFORMATION CALL: 1-800-522-6752

4 PRELIMINARY - NOT FOR PRODUCTION.

5 OBSOLETE PARTS: OBSOLETE CIS STREAMLINING
PER D.RENAUD/D.SINISI

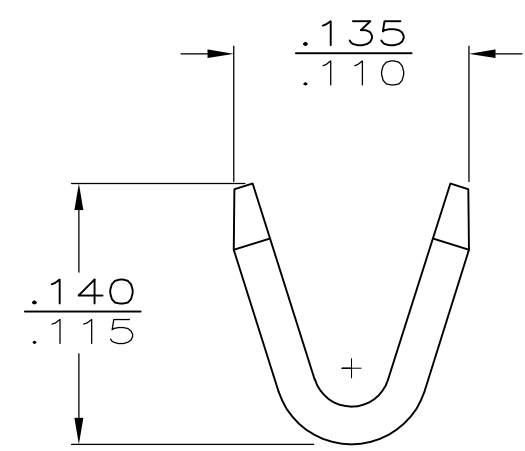
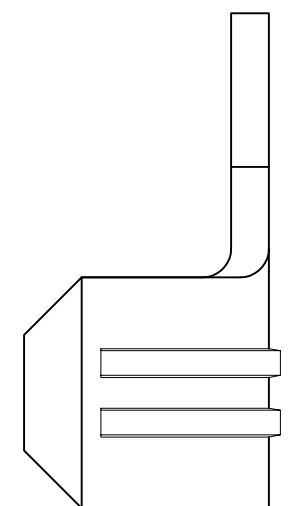
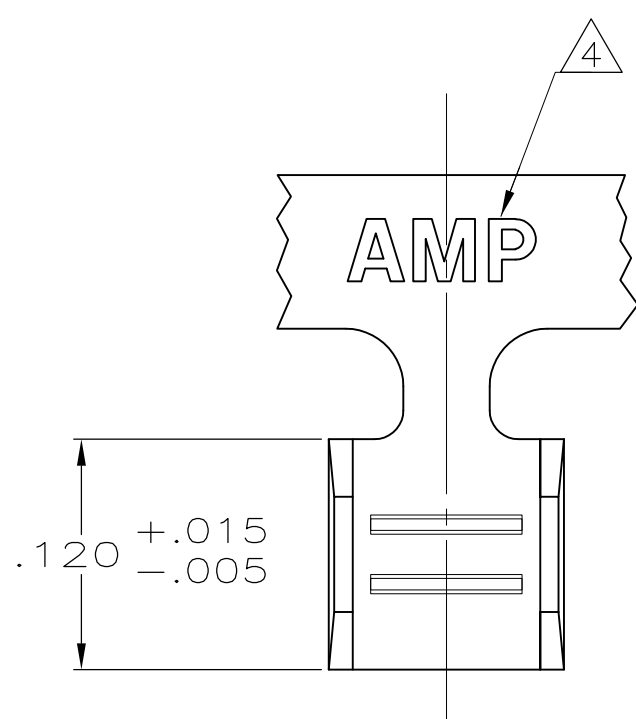

WIRE SIZE CMA	FINISH	MATERIAL	PART NUMBER
	-	.020 STAINLESS STEEL	61769-4
	-	.020 BRASS	61769-3
1200-2600	NICKEL	.020 STEEL	61769-2
	-	.020 BRASS	61769-1

5 OBSOLETE

THIS DRAWING IS A CONTROLLED DOCUMENT.		DWN MICHAEL S. FEHER 19DEC2002	Tyco Electronics Corporation Harrisburg, PA 17105-3608	
DIMENSIONS: INCHES	TOLERANCES UNLESS OTHERWISE SPECIFIED:	CHK GARY PORTA 19DEC2002	NAME -	
	0 PLC ± -	APVD GARY PORTA 19DEC2002	PRODUCT SPEC -	
	1 PLC ± -	APPLICATION SPEC -	SIZE A3	CAGE CODE 00779
MATERIAL SEE TABLE	FINISH SEE TABLE	WEIGHT -	DRAWING NO C-61769	RESTRICTED TO -
CUSTOMER DRAWING			SCALE 10:1	SHEET 1 OF 1
			REV G1	

单击下面可查看定价，库存，交付和生命周期等信息

[>>TE Connectivity\(泰科\)](#)