

LOC	DW	DIST	REVISIONS			
P	LTR	DESCRIPTION	DATE	DWN	APVD	
B3		REVISED (ECR-12-012115, OBSOLETE P/N 2-2, 2-3, 2-4, 2-7, 2-8, 7-2, 7-3)	23OCT'12	E.L.	W.K.	

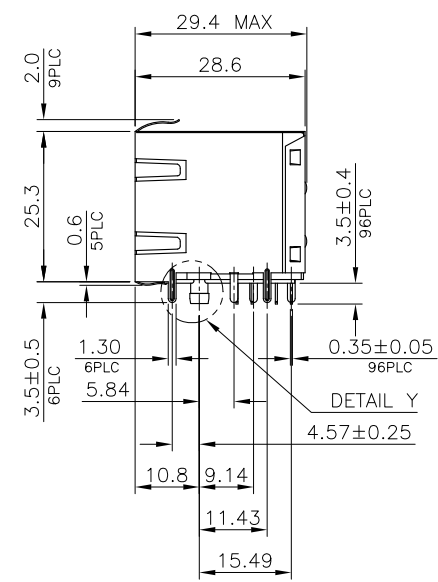

NOTE:
 1. MATERIAL:
 1.1 HOUSING & COVER: THERMOPLASTIC (SEE TABLE), WITH 30% GF, UL94V-0, COLOR: BLACK.
 1.2 INSERT HOUSING: PBT, WITH 30% GF, UL94V-0, COLOR: BLACK.
 1.3 CONTACTS: PHOSPHOR BRONZE.
 1.4 SHELL & INNER SHELL: BRASS.
 2. FINISH:
 2.1 CONTACTS: (SEE TABLE) GOLD PLATED ON CONTACT AREA. GOLD FLASH ON SOLDER TAIL.
 1.27um [50u"] MIN. NICKEL UNDERPLATED OVERALL.
 2.2 SHELL: Δ - GOLD FLASH OVER 0.508um [20u"] MIN. NICKEL PLATED OVERALL.
 Δ - 0.508um [25u"] MIN. NICKEL PLATED OVERALL.
 Δ WAVE SOLDER CAPABLE TO 220°C.
 Δ WAVE SOLDER CAPABLE TO 265°C PER TE TEST SPEC. 109-202, CONDITION B.
 Δ OBSOLETE PARTS:
 OBSOLETE CIS STREAMLINING PER D.RENAUD/D.SINISI.

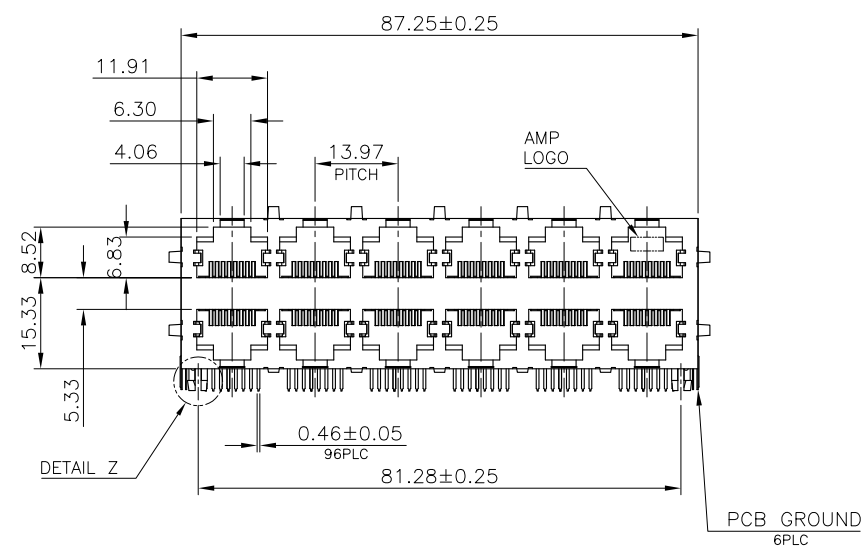
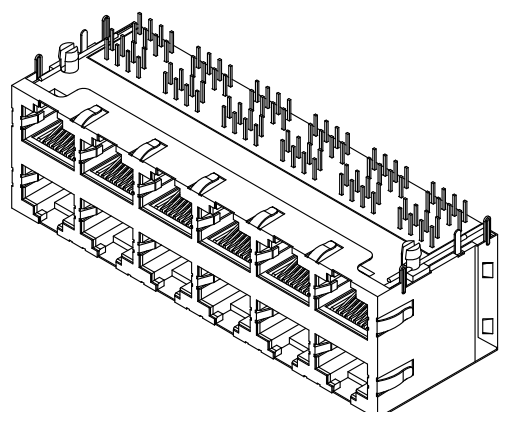
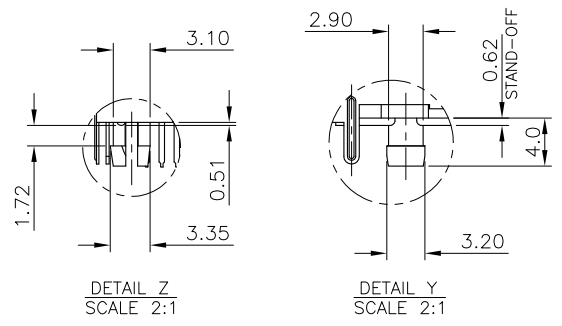
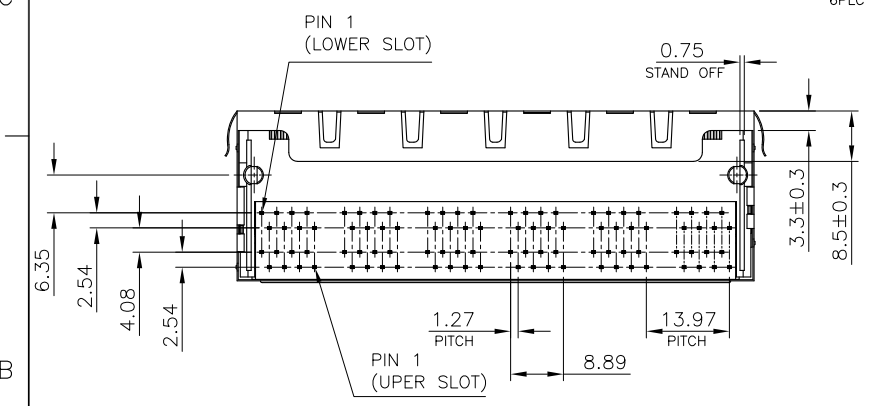

OBSOLETE	PA46	12	Δ	0.762um[30u"]	6-1734473-6
				0.381um[15u"]	6-1734473-5
				0.152um[6u"]	6-1734473-4
				0.762um[30u"]	6-1734473-3
				0.381um[15u"]	6-1734473-2
				0.152um[6u"]	6-1734473-1
	PBT	12	Δ	0.762um[30u"]	1-1734473-6
				0.381um[15u"]	1-1734473-5
				0.152um[6u"]	1-1734473-4
				0.762um[30u"]	1-1734473-3
				0.381um[15u"]	1-1734473-2
				0.152um[6u"]	1-1734473-1
HOUSING MATERIAL	NO. OF PORTS	SHIELD PLATED	MIN. GOLD THICKNESS	PART NUMBER	

THIS DRAWING IS A CONTROLLED DOCUMENT.		DWN	S. CHIEN	07MAY2009	TE Connectivity MODULAR JACK RJ45, STACKED, MULTI-PORT, SHIELDED, THRU-HOLE, PANEL GROUND
DIMENSIONS: mm		CHK	S. CHIEN	07MAY2009	
TOLERANCES UNLESS OTHERWISE SPECIFIED:		APVD	W. KODAMA	07MAY2009	
0 PLC ± - 1 PLC ± 0.3 2 PLC ± 0.2 3 PLC ± 0.15 4 PLC ± 0.15 ANGLES ± ± 3°		PRODUCT SPEC	108-57535		
MATERIAL	SEE NOTE	FINISH	SEE NOTE	WEIGHT	70 GRAMS
CUSTOMER DRAWING		SIZE	A3	CAGE CODE	00779
SCALE		DRAWING NO	C=1734473		RESTRICTED TO
SHEET		1 of 6		REV	B3

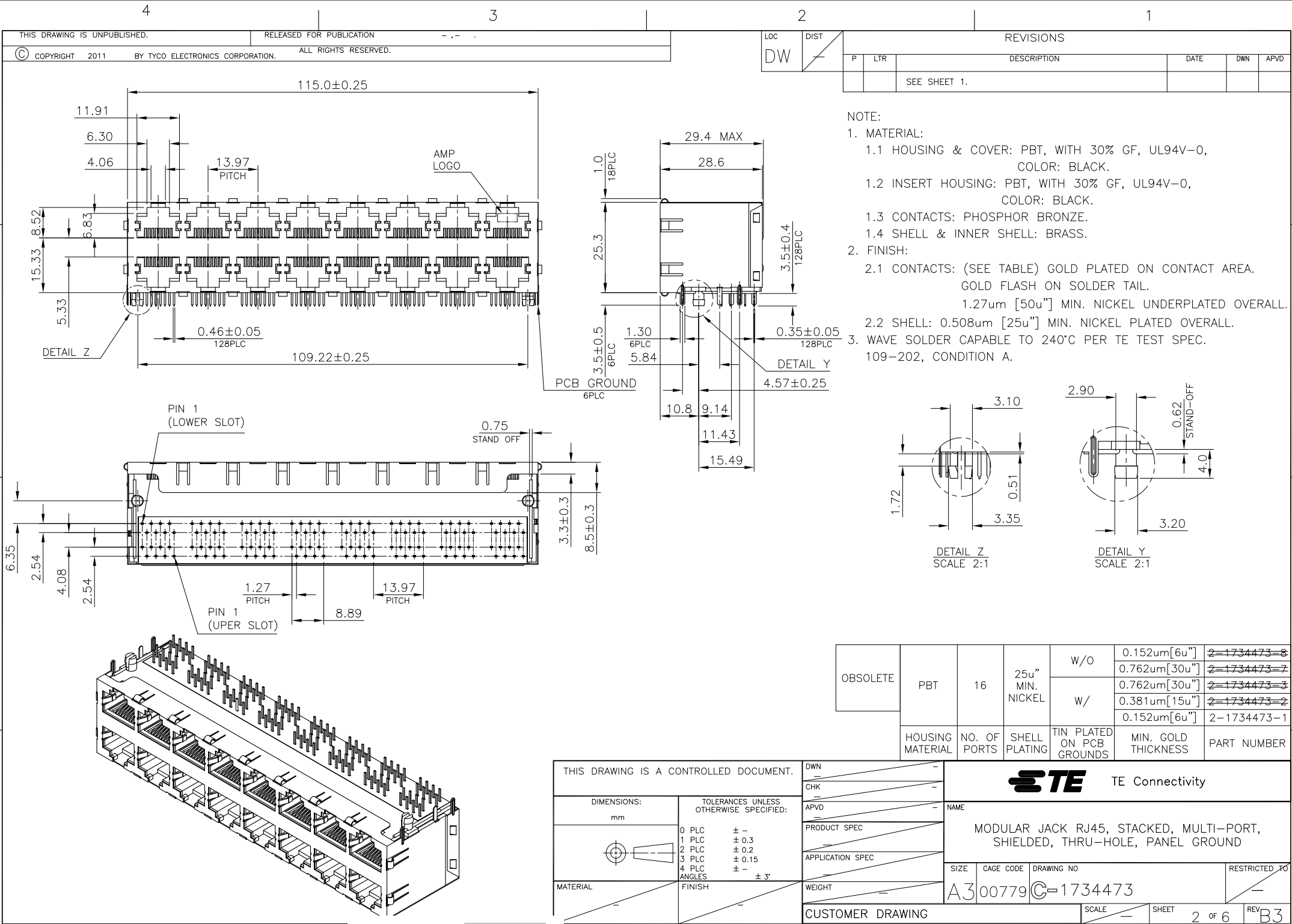

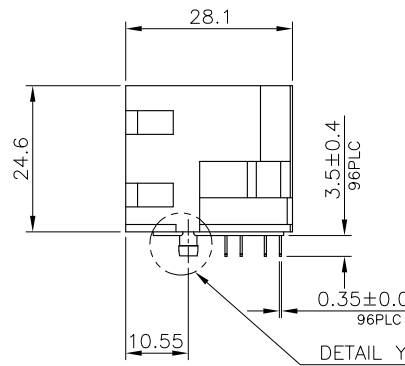
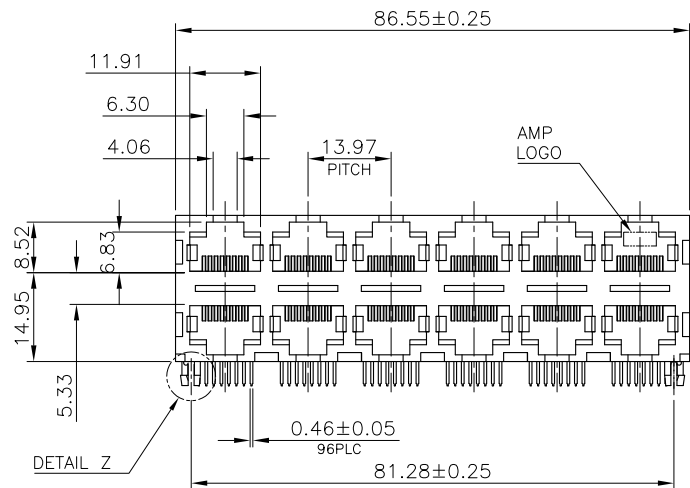

NOTE:
 1. MATERIAL:
 1.1 HOUSING & COVER: PBT, WITH 30% GF, UL94V-0, COLOR: BLACK.
 1.2 INSERT HOUSING: PBT, WITH 30% GF, UL94V-0, COLOR: BLACK.
 1.3 CONTACTS: PHOSPHOR BRONZE.
 2. FINISH:
 2.1 CONTACTS: (SEE TABLE) GOLD PLATED ON CONTACT AREA. GOLD FLASH ON SOLDER TAIL. 1.27um [50u"] MIN. NICKEL UNDERPLATED OVERALL.
 3. WAVE SOLDER CAPABLE TO 240°C PER TE TEST SPEC. 109-202, CONDITION A.
 4. THIS PRODUCT WITHOUT SHELL.

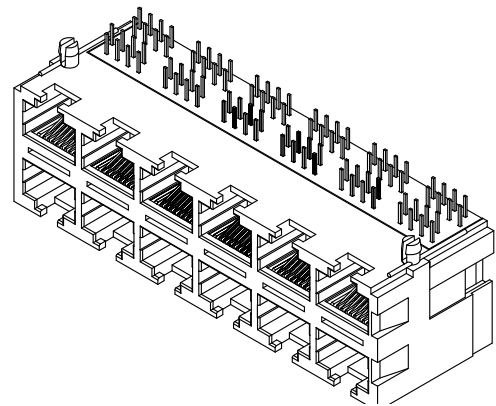
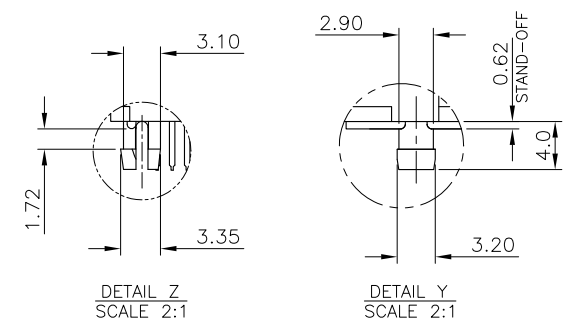
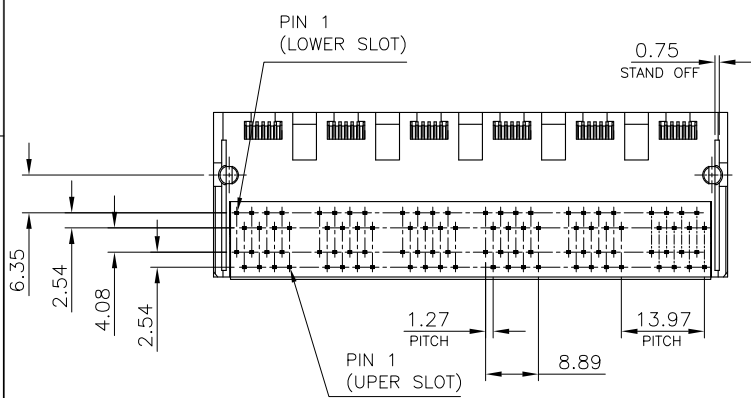

OBSOLETE	PBT	12	0.762um[30u"]	7-1734473-3
			0.381um[15u"]	7-1734473-2
OBSOLETE			0.152um[6u"]	7-1734473-4
	HOUSING MATERIAL	NO. OF PORTS	MIN. GOLD THICKNESS	PART NUMBER

THIS DRAWING IS A CONTROLLED DOCUMENT.

DIMENSIONS: mm

TOLERANCES UNLESS OTHERWISE SPECIFIED:
 0 PLC ± -
 1 PLC ± 0.3
 2 PLC ± 0.2
 3 PLC ± 0.15
 4 PLC ± -
 ANGLES ± 3'

MATERIAL FINISH

DWN
 CHK
 APVD
 PRODUCT SPEC
 APPLICATION SPEC
 WEIGHT

NAME
 MODULAR JACK RJ45, STACKED, MULTI-PORT, SHIELDED, THRU-HOLE, PANEL GROUND

SIZE A3 CAGE CODE 00779 DRAWING NO. C=1734473 RESTRICTED TO

CUSTOMER DRAWING SCALE SHEET 3 of 6 REV B3

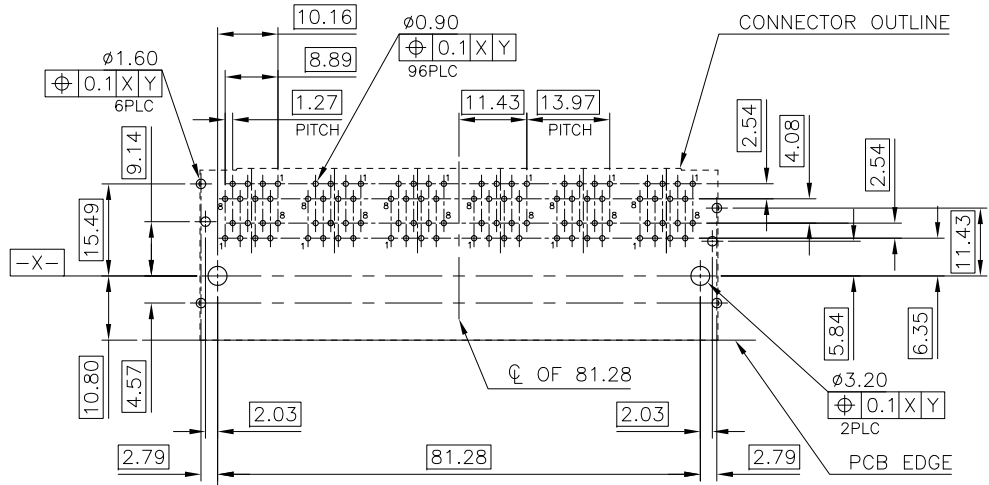

RECOMMENDED PCB LAYOUT
 TOLERANCE: ±0.05, PCB THICKNESS: 1.6mm
 FOR PN 1-1734473-X ; 6-1734473-X

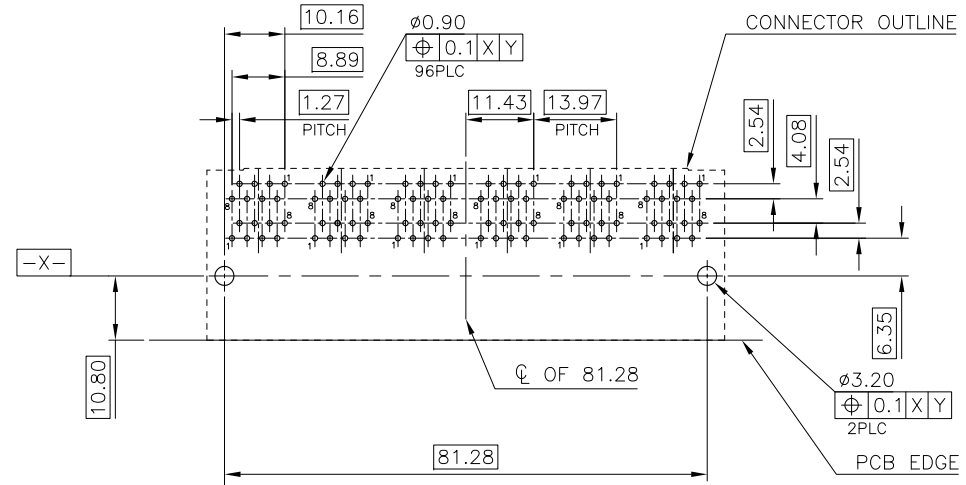

RECOMMENDED PCB LAYOUT
 TOLERANCE: ±0.05, PCB THICKNESS: 1.6mm
 FOR PN 7-1734473-X

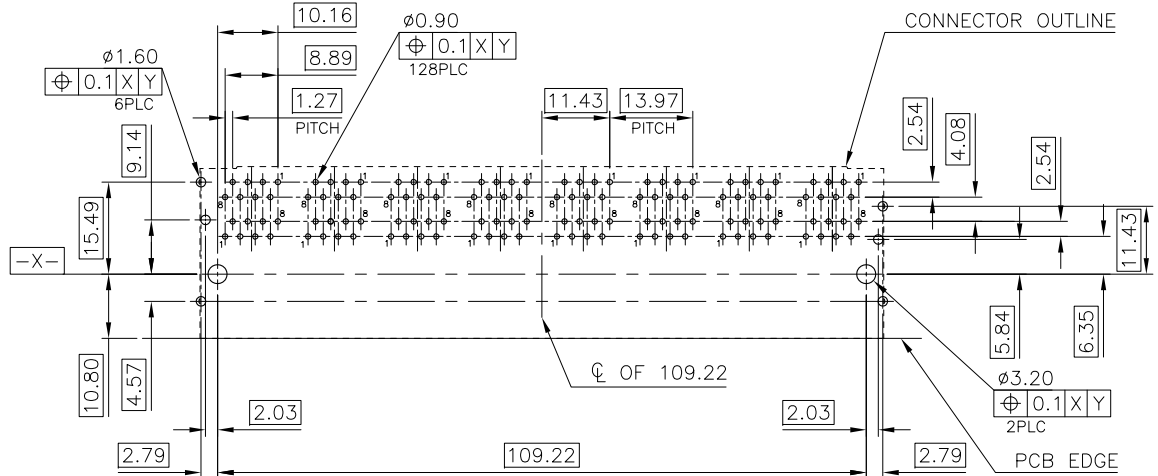

RECOMMENDED PCB LAYOUT
 TOLERANCE: ±0.05, PCB THICKNESS: 1.6mm
 FOR PN 2-1734473-X

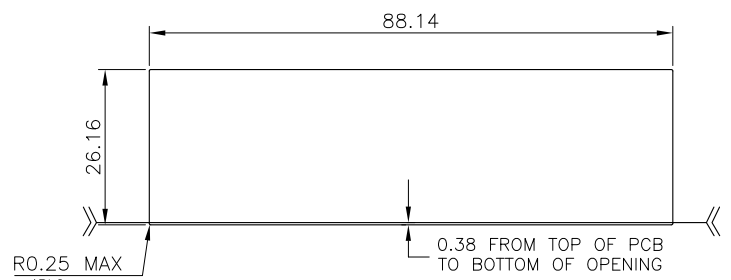

SUGGESTED PANEL CUTOUT
 FOR PN 1-1734473-X ; 6-1734473-X

THIS DRAWING IS A CONTROLLED DOCUMENT.		DWN	TE Connectivity		
DIMENSIONS: mm		CHK	NAME		
TOLERANCES UNLESS OTHERWISE SPECIFIED:		APVD	MODULAR JACK RJ45, STACKED, MULTI-PORT, SHIELDED, THRU-HOLE, PANEL GROUND		
0 PLC ± -		PRODUCT SPEC	SIZE	CAGE CODE	DRAWING NO
1 PLC ± 0.3		APPLICATION SPEC	A3	00779	C=1734473
2 PLC ± 0.2		WEIGHT	RESTRICTED TO		
3 PLC ± 0.15		CUSTOMER DRAWING	SCALE		
4 PLC ± -			SHEET 4 of 6		
ANGLES ± 3'			REV B3		
MATERIAL	FINISH				

THIS DRAWING IS UNPUBLISHED. RELEASED FOR PUBLICATION
 © COPYRIGHT 2011 BY TYCO ELECTRONICS CORPORATION. ALL RIGHTS RESERVED.

LOC	DIST	REVISIONS					
DW		P	LTR	DESCRIPTION	DATE	DWN	APVD
				SEE SHEET 1.			

1. MATERIAL:
 - 1.1 TRAY: PVC.
 - 1.2 BOX: CORRUGATED FIBER.
2. DIMENSION: SEE DRAWING
3. QUANTITY: SEE TABLE
4. WEIGHT: SEE TABLE
5. EACH BAG SHALL BE INCLUDED:
 - * DESICCANT

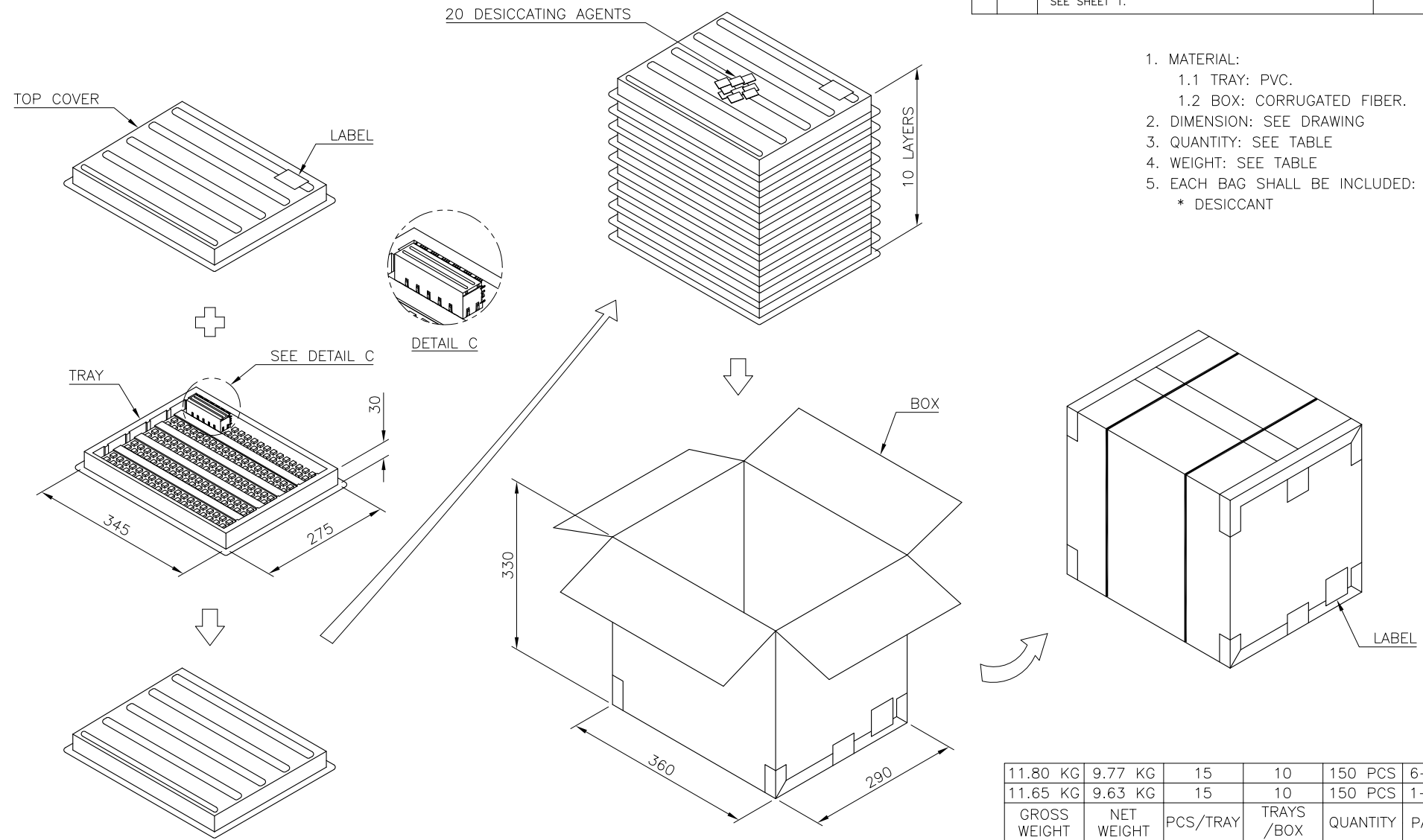

11.80 KG	9.77 KG	15	10	150 PCS	6-1734473-X
11.65 KG	9.63 KG	15	10	150 PCS	1-1734473-X
GROSS WEIGHT	NET WEIGHT	PCS/TRAY	TRAYS /BOX	QUANTITY	PART NUMBER

THIS DRAWING IS A CONTROLLED DOCUMENT.		DWN	TE Connectivity		
DIMENSIONS: mm		CHK	NAME		
TOLERANCES UNLESS OTHERWISE SPECIFIED:		APVD	MODULAR JACK RJ45, STACKED, MULTI-PORT, SHIELDED, THRU-HOLE, PANEL GROUND		
0 PLC ± - 1 PLC ± 0.3 2 PLC ± 0.2 3 PLC ± 0.15 4 PLC ± - ANGLES ± 3°		PRODUCT SPEC	SIZE		
MATERIAL		APPLICATION SPEC	CAGE CODE	DRAWING NO	RESTRICTED TO
FINISH		WEIGHT	A3	00779	©=1734473
		CUSTOMER DRAWING	SCALE	SHEET	REV
				5 of 6	B3

THIS DRAWING IS UNPUBLISHED. RELEASED FOR PUBLICATION
 © COPYRIGHT 2011 BY TYCO ELECTRONICS CORPORATION. ALL RIGHTS RESERVED.

LOC DW	DIST	REVISIONS			
P	LTR	DESCRIPTION	DATE	DWN	APVD
		SEE SHEET 1.			

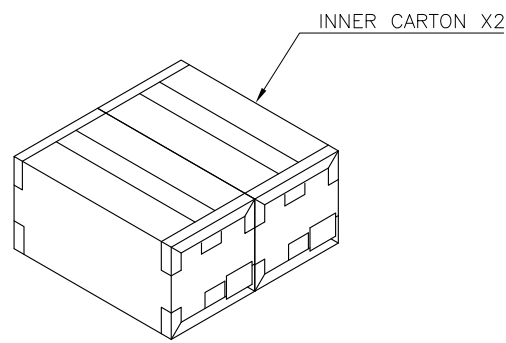
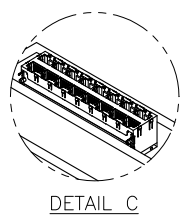
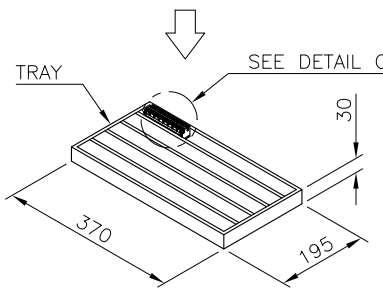
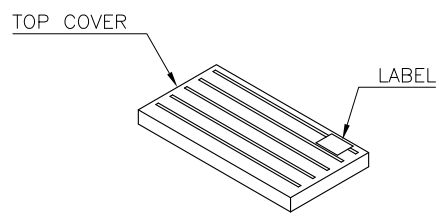

- MATERIAL:
 - 1.1 TRAY: PVC.
 - 1.2 BOX: CORRUGATED FIBER.
- DIMENSION: SEE DRAWING
- QUANTITY: SEE TABLE
- WEIGHT: SEE TABLE
- EACH BAG SHALL BE INCLUDED:
 - * DESICCANT

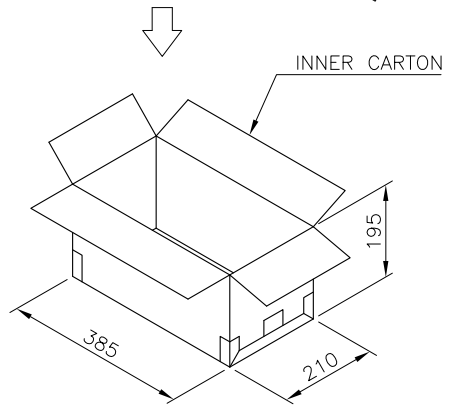
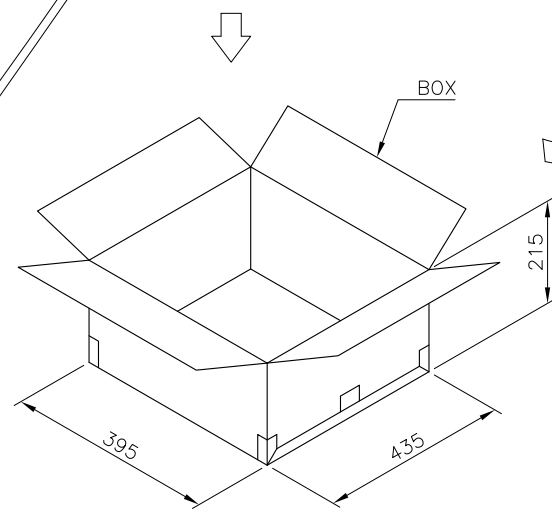
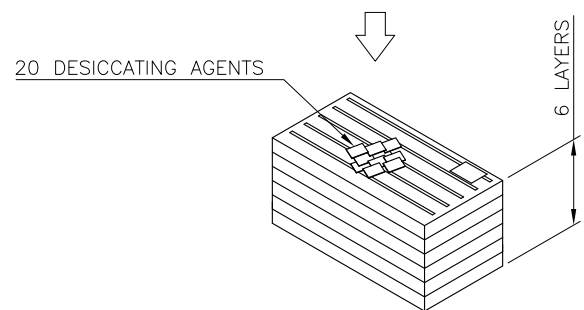
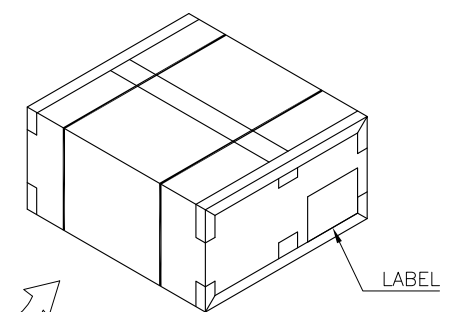

14.20 KG	11.55 KG	20	6	2	240 PCS	7-1734473-X
18.50 KG	15.82 KG	15	6	2	180 PCS	2-1734473-X
GROSS WEIGHT	NET WEIGHT	PCS/TRAY	TRAYS/INNER BOX	INNER BOX/BOX	QUANTITY	PART NUMBER

THIS DRAWING IS A CONTROLLED DOCUMENT.

DIMENSIONS: mm	TOLERANCES UNLESS OTHERWISE SPECIFIED:	DWN	 TE Connectivity
0 PLC ± -	1 PLC ± 0.3	CHK	
2 PLC ± 0.2	3 PLC ± 0.15	APVD	
4 PLC ANGLES ± - ± 3'		PRODUCT SPEC	
MATERIAL	FINISH	APPLICATION SPEC	NAME
		WEIGHT	MODULAR JACK RJ45, STACKED, MULTI-PORT, SHIELDED, THRU-HOLE, PANEL GROUND
		CUSTOMER DRAWING	SIZE CAGE CODE DRAWING NO RESTRICTED TO
			A3 00779 C=1734473
		SCALE	SHEET 6 of 6 REV B3

单击下面可查看定价，库存，交付和生命周期等信息

[>>TE Connectivity\(泰科\)](#)