

DIESES ZEICHNUNGSDOKUMENT WIRD DURCH AMP INCORPORATED KONTROLLIERT.
 AENDERUNGEN, DIE DEM TECHNISCHEN FORTSCHRITT DIENEN, SIND VORBEHALTEN.
 DEN JEWEIFS LETZTGUELTIGEN AENDERUNGSSTAND ERFAHREN SIE AUF ANFRAGE.

THIS DRAWING IS A CONTROLLED DOCUMENT FOR AMP INCORPORATED.
 IT IS SUBJECT TO CHANGE AND THE CONTROLLING ENGINEERING
 ORGANIZATION SHOULD BE CONTACTED FOR THE LATEST REVISION.

THIS DRAWING IS UNCLASSIFIED. ALL RIGHTS RESERVED. BY AMP INCORPORATED. ALL RIGHTS RESERVED. FREI FÜR VERÖFFENTLICHUNG. ALLE RECHTE VORBEHALTEN. COPYRIGHT 19-

MATED WITH, PASSEND ZU:	LOC	DIST	REVISIONS ÄNDERUNGEN DESCRIPTION BESCHREIBUNG				DATE	DWN	APVD
-	AI	-	P	LTR					
PROJEKT NR.: 87-9187				E5	Umgeladen auf neues Standardformat Blätter vereinzelt Mass 7.3 war 7.2	13JAN98	PG	DK	

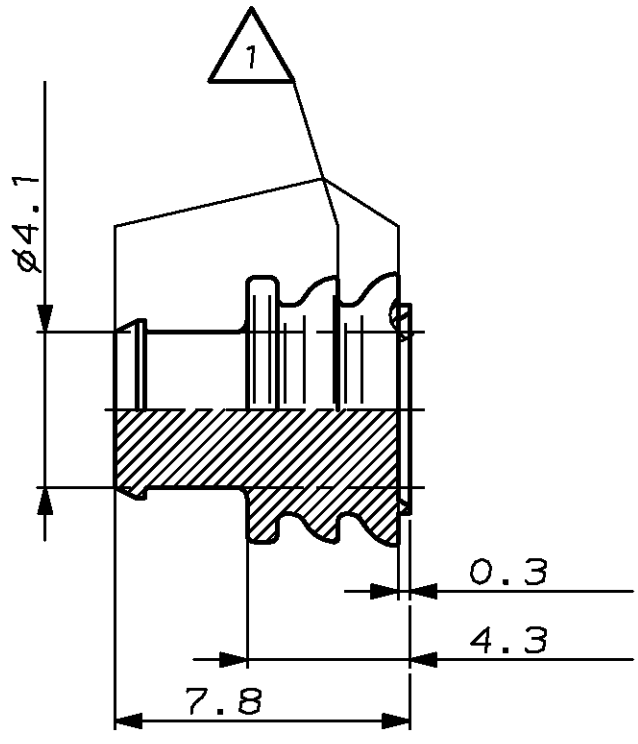
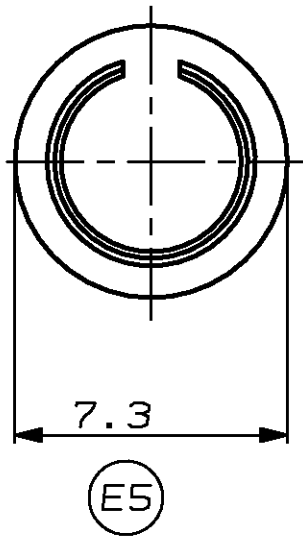

1 Werkzeugtrenngrat max. 0.5 hoch und 0.02 dick zulässig (sonst kein Grat zulässig)

Für Kammer ϕ 6.4mm



M 1:1

-	828986-1	E	-	SILICON ELASTOMER MVQ 50	braun RAL 8007	-	-
-	AMP PART NO	REV.	PCS.	MATERIAL	SURFACE COLOR	DESCRIPTION	

DIMENSIONS, DIMENSIONEN, mm TOLERANCES UNLESS OTHERWISE SPECIFIED, ALLGEMEINTOLERANZEN \pm 0.15 \pm 0.25 \pm 0.5 \pm 1 \pm 1.5 \pm 2 \pm 3 \pm 4 \pm 5 \pm 6 \pm 8 \pm 10 \pm 12 \pm 15 \pm 20 \pm 25 \pm 30 \pm 40 \pm 50 \pm 60 \pm 80 \pm 100 \pm 120 \pm 150 n. DIN 16901 - 150 ANGLES/WINKEL \pm	DWN P. Gaupp 17 APR 97	MATERIAL	FINISH OBERFLAECHE/FARBE	-
	CHK D. Kümpel 21 APR 97	AMP AMP Deutschland GmbH D - 63225 Langen		
APVD -	PRODUCT SPEC PRODUKTSPEZ. 108-18263-1	NAME 2.5mm System, Blindstopfen 2.5MM SYSTEM, CAVITY PLUG		
APPLICATION SPEC VERARBEITUNGSSPEZ. -	WEIGHT GEWICHT -	SIZE A4	CAGE CODE 00779	DRAWING NO ZEICHNUNGS-NR. C-828986
CUSTOMER DRAWING		/KUNDENZEICHNUNG		RESTRICTED TO NUR FUER -
AMP 1469-35 REV 27JUN96		MASSSTAB 5:1	BLATT 1 OF 2 VON 2	E5

单击下面可查看定价，库存，交付和生命周期等信息

[>>TE Connectivity\(泰科\)](#)