

THIS DRAWING IS UNPUBLISHED. RELEASED FOR PUBLICATION
 © COPYRIGHT BY TYCO ELECTRONICS CORPORATION. ALL RIGHTS RESERVED.

LOC	DIST	REVISIONS			
P	LTR	DESCRIPTION	DATE	DWN	APVD
AJ	16	A	REV PER ECO 06-002539	06APR06	GB JH
		A1	REVISED PER ECO-09-024606	31OCT09	KK AEG

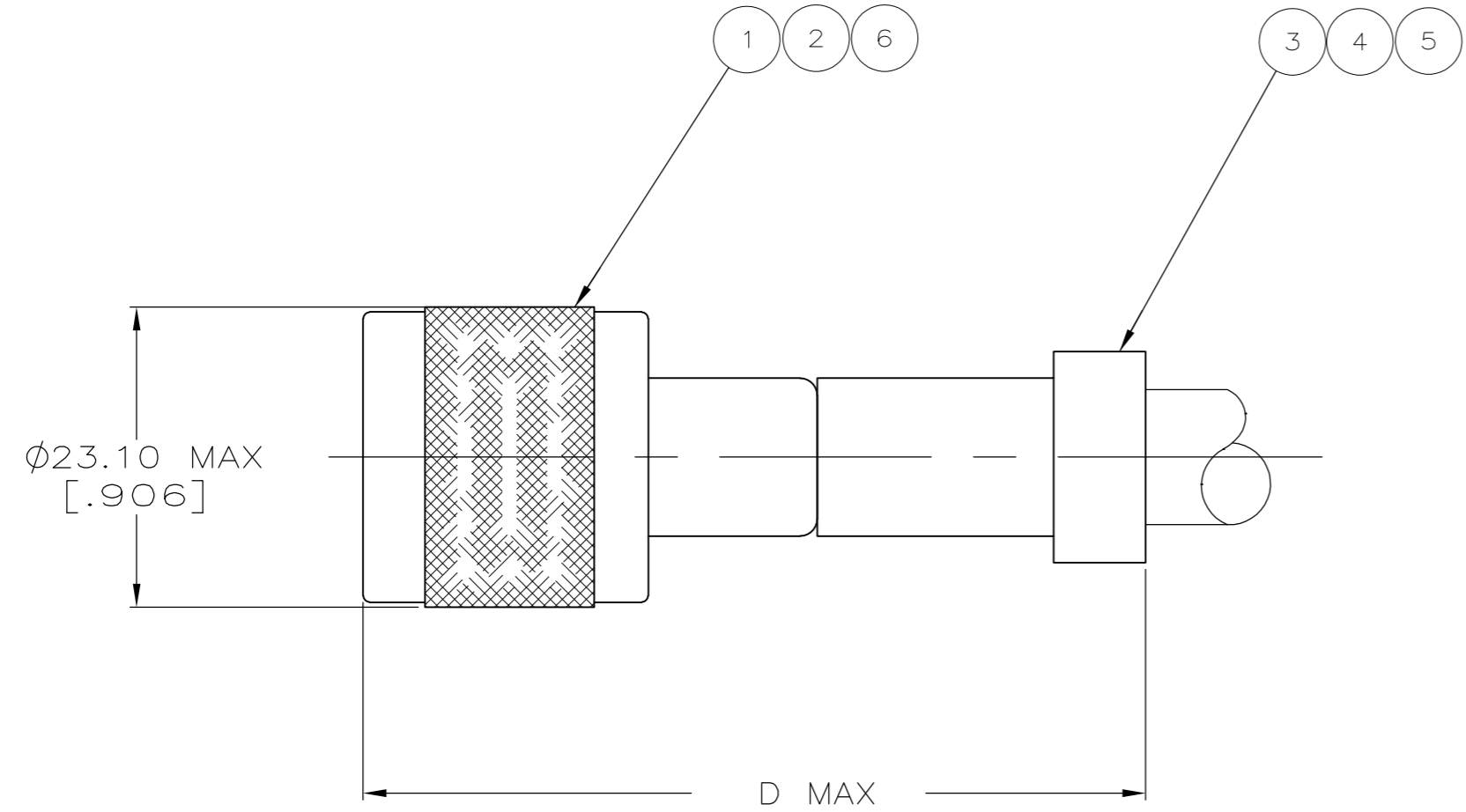

- ① FOR USE WITH: RG-149/U, & 391/U STANDARD CABLE.
- ② FOR USE WITH: RG-150/U, & 392/U ARMOR CABLE.
- ③ USE CRIMPING TOOL: 220015-1 FOR STANDARD CABLE.
- ④ USE CRIMPING TOOLS: 220015-1, & 220042-1 FOR ARMOR CABLE.
- ⑤ USE CRIMPING TOOL: 220045-3.
- ⑥ SEE INSTRUCTION SHEET 408-2338.
- ⑦ P/N 5225744-4 IS RATED AT 2300 VAC.
- ⑧ OBSOLETE PARTS: OBSOLETE CIS STREAMLINING PER D.RENAUD/D.SINISI

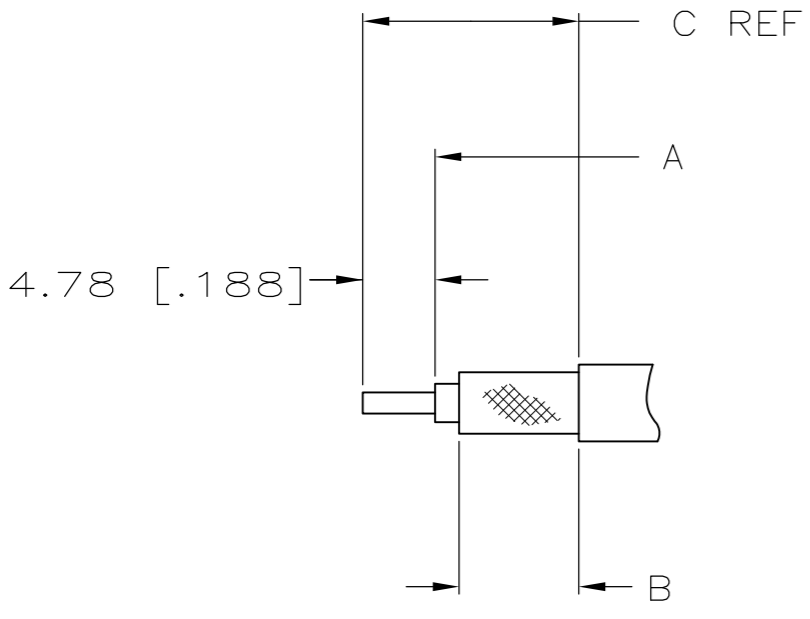

RECOMMENDED STRIP LENGTH FOR STANDARD COAX CABLE

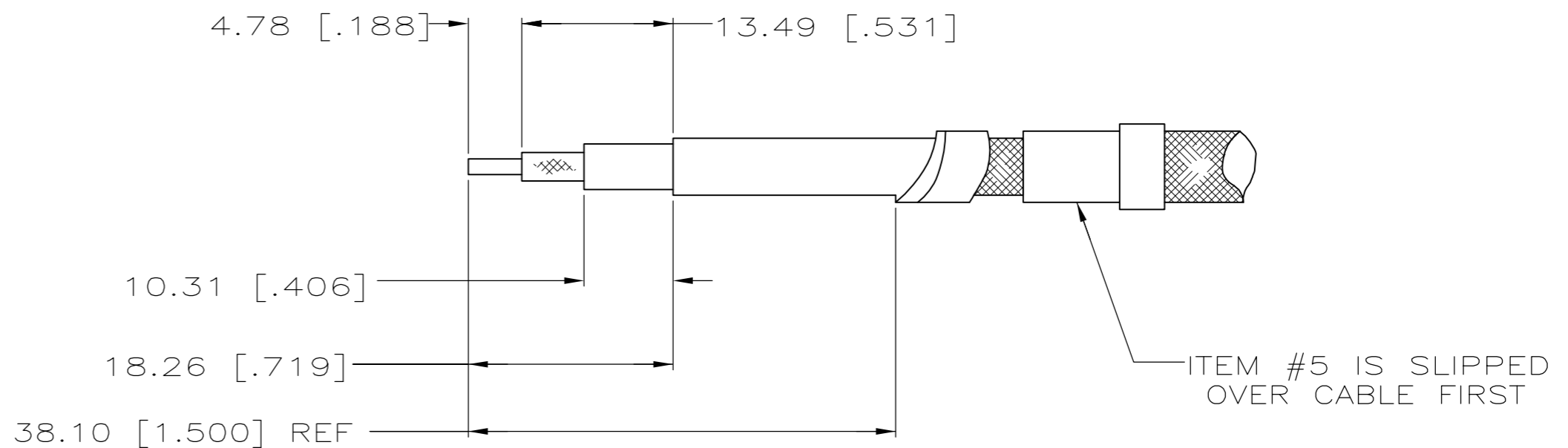

RECOMMENDED STRIP LENGTH FOR ARMOR CABLE

⑧ OBSOLETE	⑦	RG-59/U CABLE	⑤	225592-3	-	-	9-225560-3	1-225343-0	9-227560-0	5225744-4
		① ② ③ ④		-	225326-2	9-225325-0	1-331987-9	226719-2	9-225745-0	5225744-3
		FOR USE WITH	⑥ SEAL QTY=1	⑤ FERRULE ARMOR QTY=1	④ FERRULE BRAID QTY=1	③ FERRULE QTY=1	② CONTACT QTY=1	① PLUG ASSY QTY=1		PART NUMBER

⑧ OBSOLETE	53.59 [2.110]	14.30 [.563]	7.92 [.312]	9.53 [.375]	5225744-4
	57.94 [2.281]	22.25 [.876]	12.70 [.500]	17.48 [.688]	5225744-3
	D	C	B	A	PART NUMBER

THIS DRAWING IS A CONTROLLED DOCUMENT.

DWN	J. ALCORTA - DOCK5	22APR2005	Tyco Electronics Corporation Harrisburg, PA 17105-3608
CHK	J. HAVENER	22APR2005	
APVD	G. MICHAEL	22APR2005	
NAME	A1		
PRODUCT SPEC	108-12066		PLUG, WEATHERPROOF, SERIES HN
APPLICATION SPEC	-		
WEIGHT	-		SIZE CAGE CODE DRAWING NO RESTRICTED TO
CUSTOMER DRAWING	A2 00779	C=5225744	SCALE 2:1 SHEET 1 of 1 REV A1

单击下面可查看定价，库存，交付和生命周期等信息

[>>TE Connectivity\(泰科\)](#)