

VIEW Z-Z
SHOWN WITH BRACKET REMOVED FOR CLARITY

CONTACT (QTY = NO. OF POSN)
MATL: BRASS PER ASTM-B-16, OR BERYLLIUM COPPER PER ASTM-B-194
FINISH: GOLD PER ASTM-B-488, TYPE II, GRADE C, CLASS 1.27 IN CONTACT MATING AREA, .000010 [0.0003] MIN THK GOLD PER ASTM-B-488 OVER .000050 [0.0013] MIN THK NICKEL PER SAE-AMS-QQ-N-290 ON CONTACT BODY

1. SEE SHEET 2 FOR RECOMMENDED P.C. BOARD LAYOUT. TRUE POSITION TOLERANCE FOR P.C. BOARD LAYOUT IS .010 [0.25] AT MAX MATERIAL CONDITION. SUGGESTED BOARD THICKNESS IS .062 [1.57]
2. THE CONNECTORS DESCRIBED IN THIS DOCUMENT MEET THE REQUIREMENTS OF MIL-C-24308 AND MATE WITH ANY RECEPTACLE CONNECTOR WITH SAME INSERT ARRANGEMENT.
3. MARKED WITH .047 [1.19]-.062 [1.57] HIGH CHARACTERS. FAR SIDE REFERS TO THE WIDE SIDE OF THE KEYSTONE. NEAR SIDE REFERS TO THE NARROW SIDE OF THE KEYSTONE. IF THE SHELL IS TOO SMALL FOR THE ENTIRE MARKING, MARKING SHALL BE SPLIT AS FOLLOWS:
 - A. *M24308* ON FRONT SHELL, FAR SIDE.
 - B. SLASH SHEET AND DASH NUMBER ON REAR SHELL, FAR SIDE.
 - C. *MFG'S* (NAME, BRAND OR LOGO) AND DATE CODE ON FRONT SHELL, NEAR SIDE.
 - D. MFG'S PART NUMBER ON REAR SHELL, NEAR SIDE.
4. REQUIREMENT FOR FULL PIN DIAMETER EXTENSION:
 - .159 [4.04] MIN, SHELL SIZES 1 AND 2.
 - .150 [3.81] MIN, SHELL SIZES 3 AND 4.
5. SOLDER DIPPED PER J-STD-001 WITH Sn63 SOLDER PER J-STD-006 IN THE ENTIRE AREA OF DIMENSION SHOWN. (1757841-6 THRU -10 ONLY.)
6. MEETS SOLDERABILITY PER MIL-STD-202 METHOD 208.

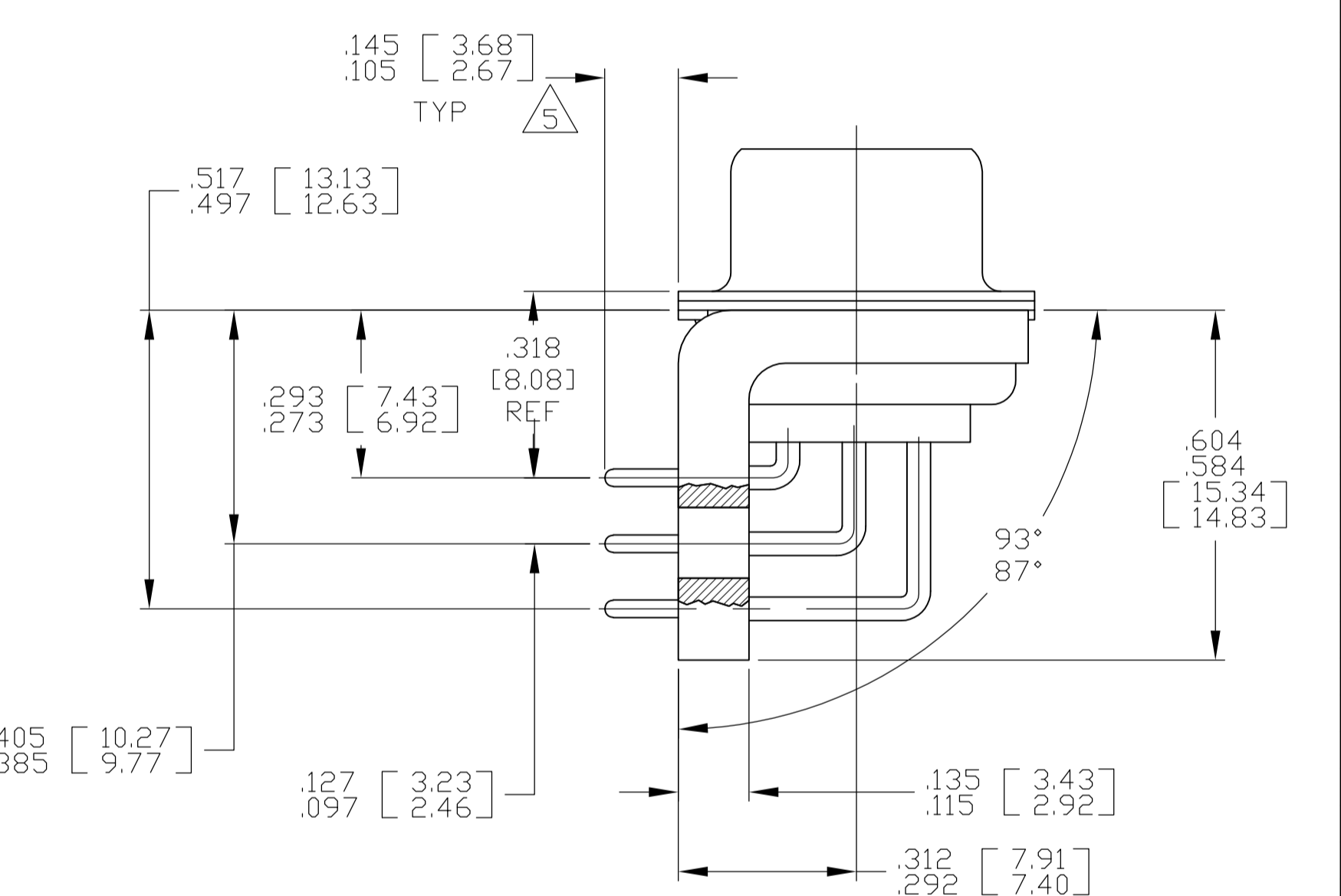
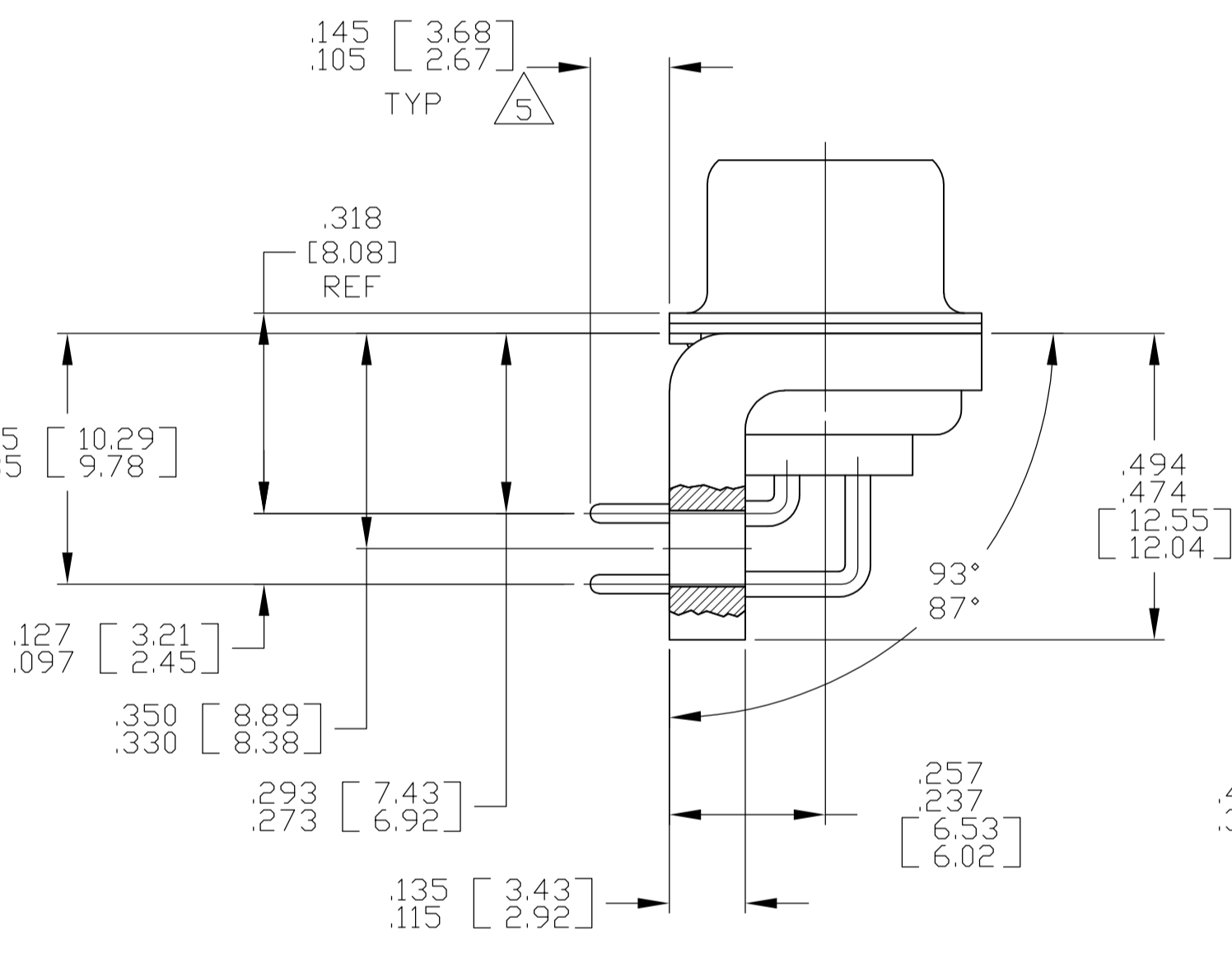
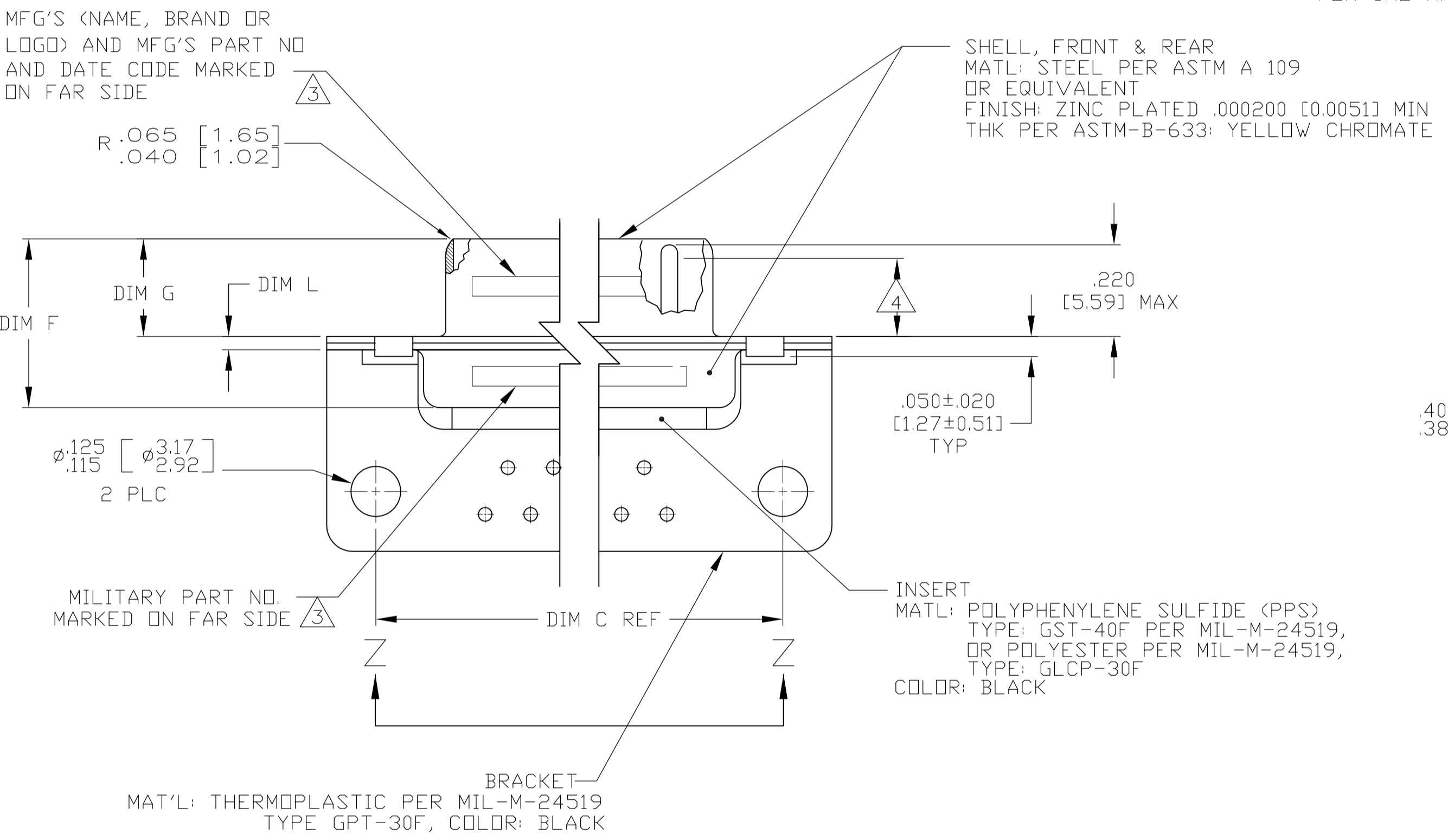

SHELL SIZES 1 THRU 4 CONTACT CONFIGURATION

SHELL SIZE 5 CONTACT CONFIGURATION

.030 [0.76] MAX EXTENSION PERMISSIBLE DUE TO SOLDER DIPPING

.049 [1.24] .029 [0.74]	.544 [13.82] .524 [13.31]	2.188 [55.58] 2.168 [55.07]	.236 [5.99] .224 [5.69]	.436 [11.07] .416 [10.57]	.620 [15.75] .590 [14.99]	.446 [11.33] .436 [11.07]	2.411 [61.24] 2.401 [60.99]	2.084 [52.55] 2.074 [52.30]	2.650 [67.31] 2.620 [66.55]	MS18277-1	50	5	M24308/24-41Z	1757841-5	1-1757841-0
.049 [1.24] .029 [0.74]	.432 [10.97] .412 [10.46]	2.282 [57.96] 2.262 [57.45]	.236 [5.99] .224 [5.69]	.436 [11.07] .416 [10.57]	.509 [12.93] .479 [12.17]	.334 [8.48] .324 [8.23]	2.505 [63.63] 2.495 [63.37]	2.187 [54.97] 2.177 [54.71]	2.744 [69.70] 2.714 [68.94]	MS18276-1	37	4	M24308/24-40Z	1757841-4	1757841-9
.049 [1.24] .029 [0.74]	.432 [10.97] .412 [10.46]	1.635 [41.53] 1.615 [41.02]	.236 [5.99] .224 [5.69]	.436 [11.07] .416 [10.57]	.509 [12.93] .479 [12.17]	.334 [8.48] .324 [8.23]	1.857 [47.17] 1.847 [46.91]	1.539 [38.51] 1.529 [38.25]	2.103 [53.42] 2.073 [52.65]	MS18275-1	25	3	M24308/24-39Z	1757841-3	1757841-8
.040 [1.02] .020 [0.51]	.432 [10.97] .412 [10.46]	1.093 [27.76] 1.073 [27.25]	.238 [6.05] .229 [5.82]	.432 [10.97] .412 [10.46]	.509 [12.93] .479 [12.17]	.334 [8.48] .324 [8.23]	1.317 [33.45] 1.307 [33.20]	.999 [24.79] .989 [24.54]	1.556 [39.52] 1.526 [38.76]	MS18274-1	15	2	M24308/24-38Z	1757841-2	1757841-7
.040 [1.02] .020 [0.51]	.432 [10.97] .412 [10.46]	.769 [19.53] .749 [19.02]	.238 [6.05] .229 [5.82]	.432 [10.97] .412 [10.46]	.509 [12.93] .479 [12.17]	.334 [8.48] .324 [8.23]	.989 [25.12] .979 [24.87]	.671 [16.46] .661 [16.21]	1.228 [31.19] 1.198 [30.43]	MS18273-1	9	1	M24308/24-37Z	1757841-1	1757841-6
.049 [1.24] .029 [0.74]	.544 [13.82] .524 [13.31]	2.188 [55.58] 2.168 [55.07]	.236 [5.99] .224 [5.69]	.436 [11.07] .416 [10.57]	.620 [15.75] .590 [14.99]	.446 [11.33] .436 [11.07]	2.411 [61.24] 2.401 [60.99]	2.084 [52.55] 2.074 [52.30]	2.650 [67.31] 2.620 [66.55]	MS18277-1	50	5	M24308/24-41Z	1757841-5	1757841-5
.049 [1.24] .029 [0.74]	.432 [10.97] .412 [10.46]	2.282 [57.96] 2.262 [57.45]	.236 [5.99] .224 [5.69]	.436 [11.07] .416 [10.57]	.509 [12.93] .479 [12.17]	.334 [8.48] .324 [8.23]	2.505 [63.63] 2.495 [63.37]	2.187 [54.97] 2.177 [54.71]	2.744 [69.70] 2.714 [68.94]	MS18276-1	37	4	M24308/24-40Z	1757841-4	1757841-4
.049 [1.24] .029 [0.74]	.432 [10.97] .412 [10.46]	1.635 [41.53] 1.615 [41.02]	.236 [5.99] .224 [5.69]	.436 [11.07] .416 [10.57]	.509 [12.93] .479 [12.17]	.334 [8.48] .324 [8.23]	1.857 [47.17] 1.847 [46.91]	1.539 [38.51] 1.529 [38.25]	2.103 [53.42] 2.073 [52.65]	MS18275-1	25	3	M24308/24-39Z	1757841-3	1757841-3
.040 [1.02] .020 [0.51]	.432 [10.97] .412 [10.46]	1.093 [27.76] 1.073 [27.25]	.238 [6.05] .229 [5.82]	.432 [10.97] .412 [10.46]	.509 [12.93] .479 [12.17]	.334 [8.48] .324 [8.23]	1.317 [33.45] 1.307 [33.20]	.999 [24.79] .989 [24.54]	1.556 [39.52] 1.526 [38.76]	MS18274-1	15	2	M24308/24-38Z	1757841-2	1757841-2
.040 [1.02] .020 [0.51]	.432 [10.97] .412 [10.46]	.769 [19.53] .749 [19.02]	.238 [6.05] .229 [5.82]	.432 [10.97] .412 [10.46]	.509 [12.93] .479 [12.17]	.334 [8.48] .324 [8.23]	.989 [25.12] .979 [24.87]	.671 [16.46] .661 [16.21]	1.228 [31.19] 1.198 [30.43]	MS18273-1	9	1	M24308/24-37Z	1757841-1	1757841-1

THIS DRAWING IS A CONTROLLED DOCUMENT.		DIM C.C. THOMAS 10FEB2008		DATE 2-13-06	
DIMENSIONS: INCHES		TOLERANCES UNLESS OTHERWISE SPECIFIED:		NAME	
0 PLC ± .005		1 PLC ± .005		D. MILLER	
2 PLC ± .005		3 PLC ± .005		D. MILLER	
4 PLC ± .005		ANGLES ± 1'		PRODUCT SPEC	
MATERIAL SEE CALLOUTS		FINISH SEE CALLOUTS		APPLICATION SPEC	
WEIGHT		SIZE		CASE CODE	
CUSTOMER DRAWING		A1		00779	
SCALE 4:1		SHEET 1 OF 2		REV B	

DETAIL K SCALE 10:1 FOR 1757841-6 THRU -10 ONLY

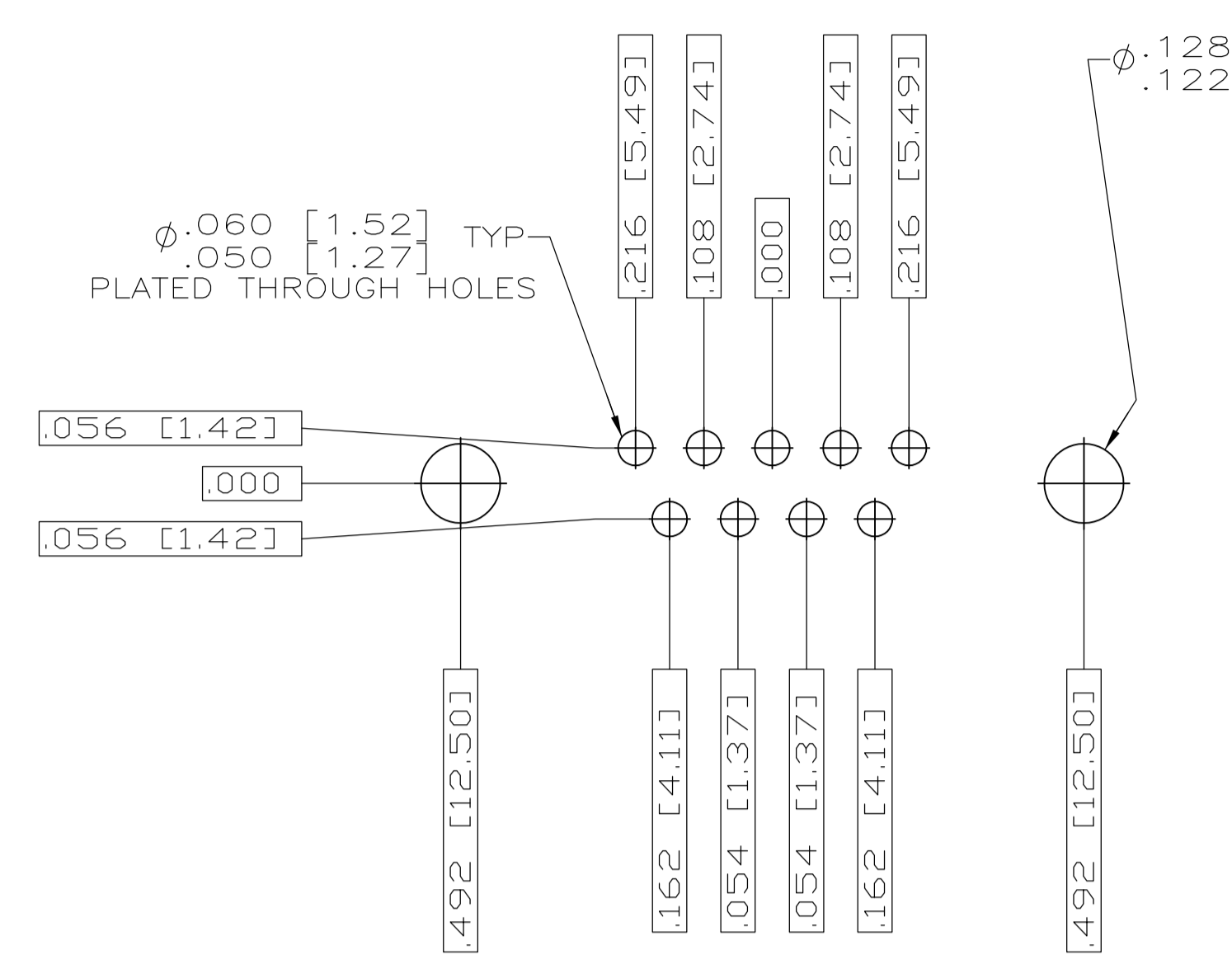

RECOMMENDED P.C. BOARD LAYOUT
SHELL SIZE 1 (9 POSITION) ⚠

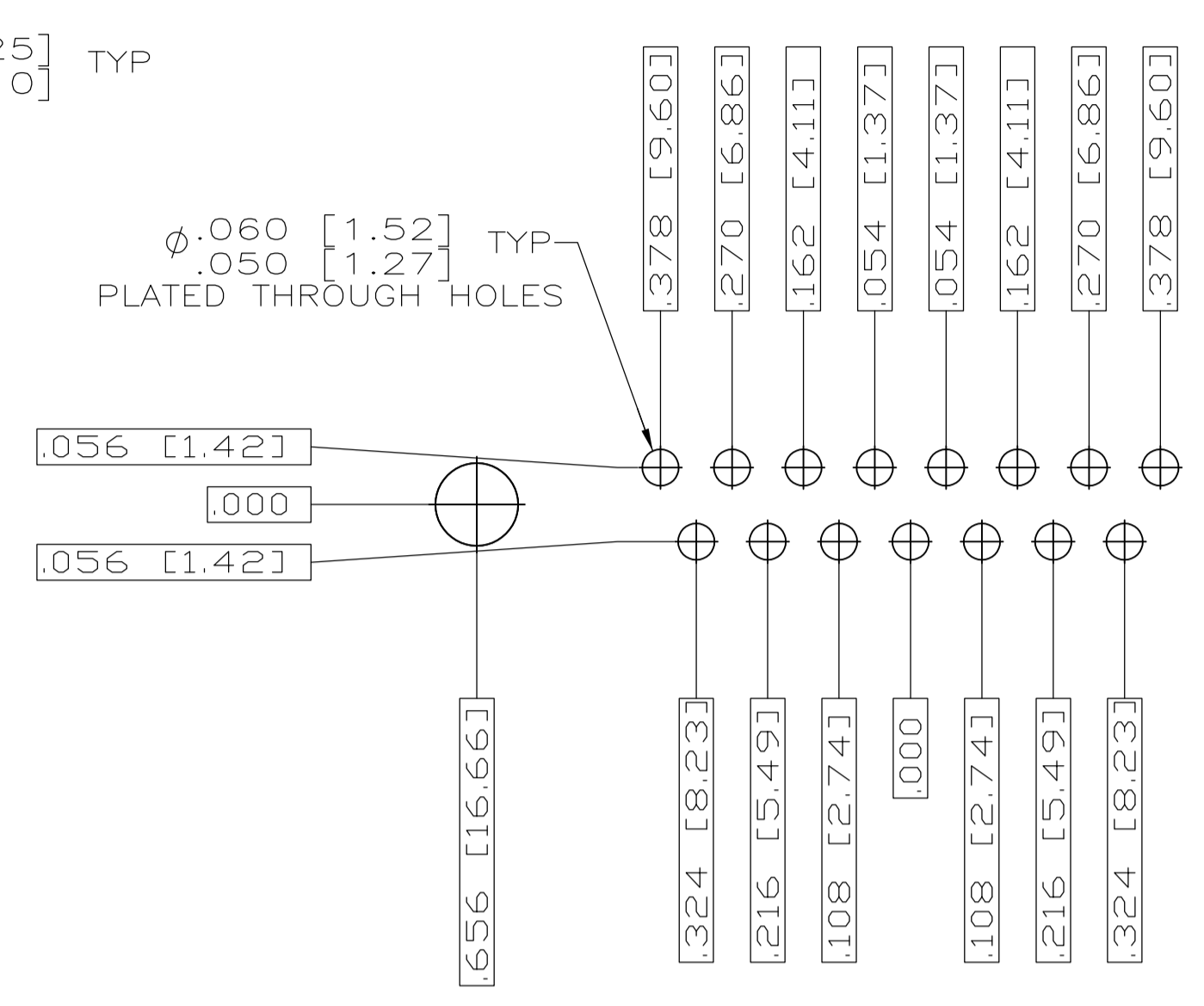

RECOMMENDED P.C. BOARD LAYOUT
SHELL SIZE 2 (15 POSITION) ⚠

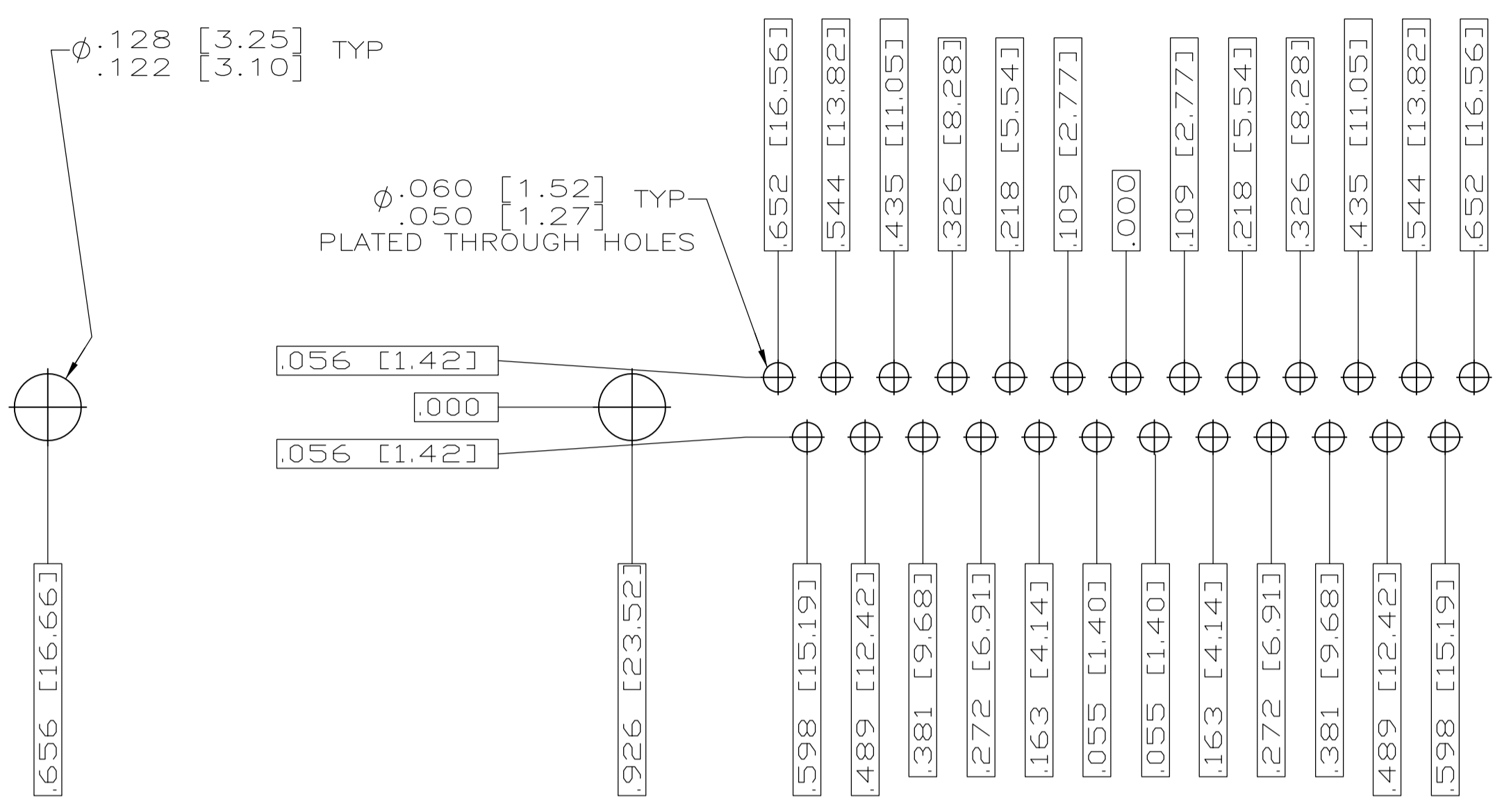

RECOMMENDED P.C. BOARD LAYOUT
SHELL SIZE 3 (25 POSITION) ⚠

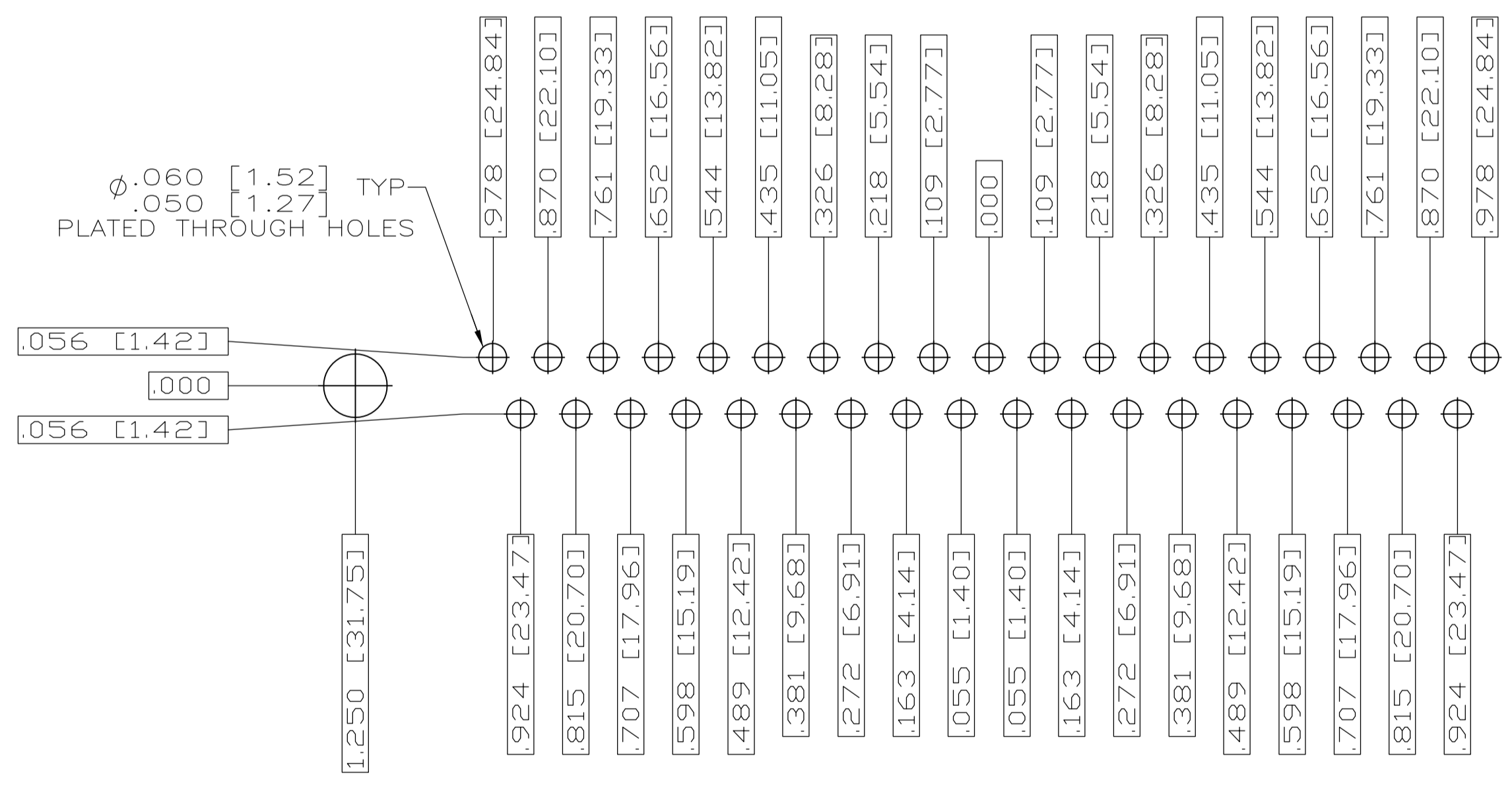

RECOMMENDED P.C. BOARD LAYOUT
SHELL SIZE 4 (37 POSITION) ⚠

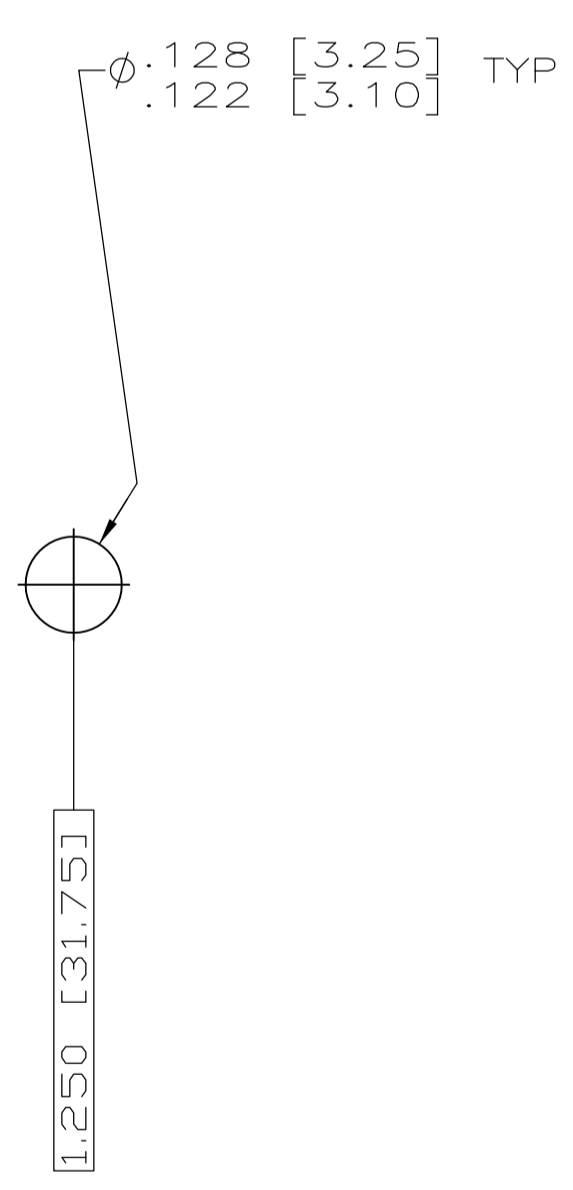

RECOMMENDED P.C. BOARD LAYOUT
SHELL SIZE 5 (50 POSITION) ⚠

THIS DRAWING IS A CONTROLLED DOCUMENT.		DWN C.C. THOMAS 2-10-06 CHK D. HOFFMAN 2-23-06 APVO D. MILLER 2-23-06	TE Connectivity	
DIMENSIONS: INCHES TOLERANCES UNLESS OTHERWISE SPECIFIED: 0 PL ± .005 1 PL ± .005 2 PL ± .005 3 PL ± .005 4 PL ± .005 ANGLES ± .1°	MATERIAL SEE CALLOUTS FINISH SEE CALLOUTS	NAME PLUG ASSY,AMPLIMITE RIGHT ANGLE,SERIES 109,SIZE 1 THRU 5 APPLICATION SPEC SIZE A1 CAGE CODE 00779 DRAWING NO. 1757841	RESTRICTED TO SCALE 4:1 SHEET 2 OF 2 REV B	CUSTOMER DRAWING

单击下面可查看定价，库存，交付和生命周期等信息

[>>TE Connectivity\(泰科\)](#)