

THIS DRAWING IS UNPUBLISHED. RELEASED FOR PUBLICATION .19  
 © COPYRIGHT 19 BY AMP INCORPORATED. ALL INTERNATIONAL RIGHTS RESERVED.

LOC	DIST	P	F	ZONE	LTR	REVISIONS	DATE	APPD
G	14			A		RELEASED PER 0720-0008-93	2-2-93	1 <sup>ST</sup> DAP

**METRIC**  
 DIMENSIONS LISTED IN mm [ INCHES ]

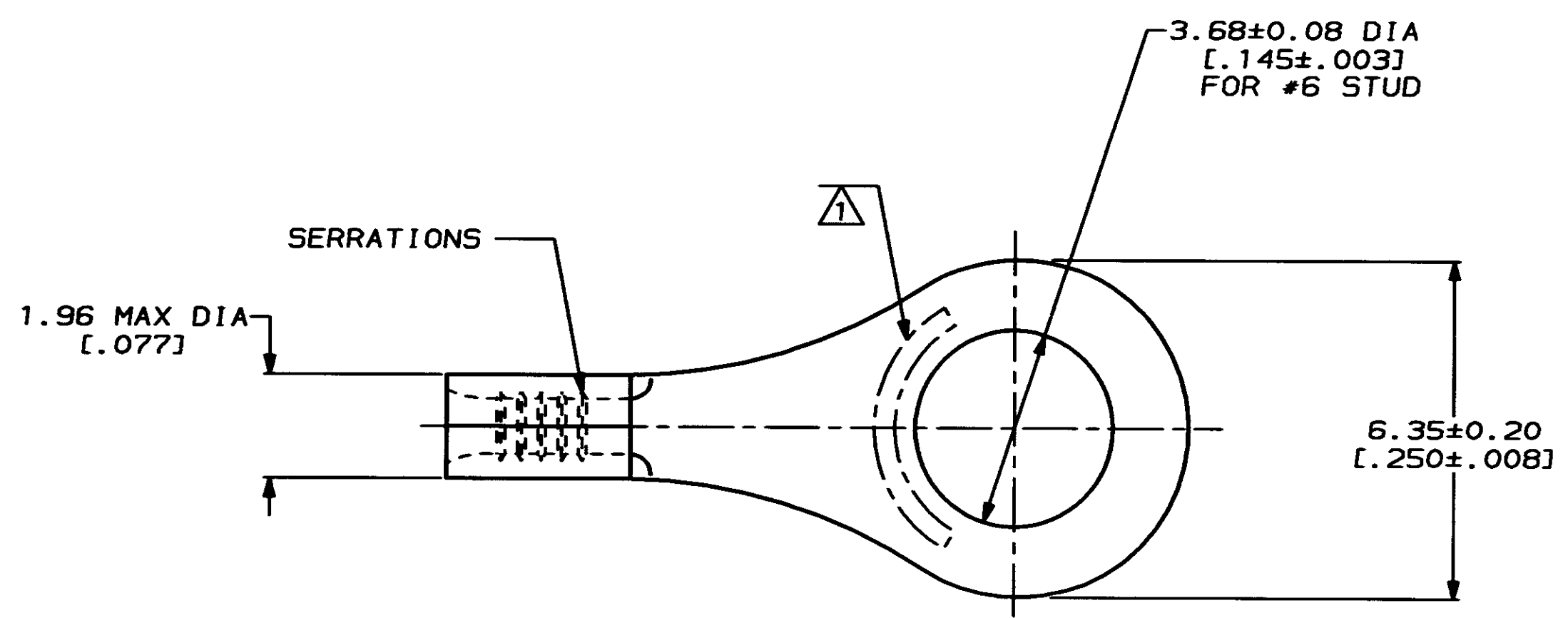

<b>AMP</b> WIRE RANGE	E13288 Listed
26-22 AWG STRANDED	NOT LISTED
LR7189 Certified	MILITARY P/N AND CLASS
NOT CERTIFIED	NOT APPLICABLE

△ STAMP AMP APPROX AS SHOWN

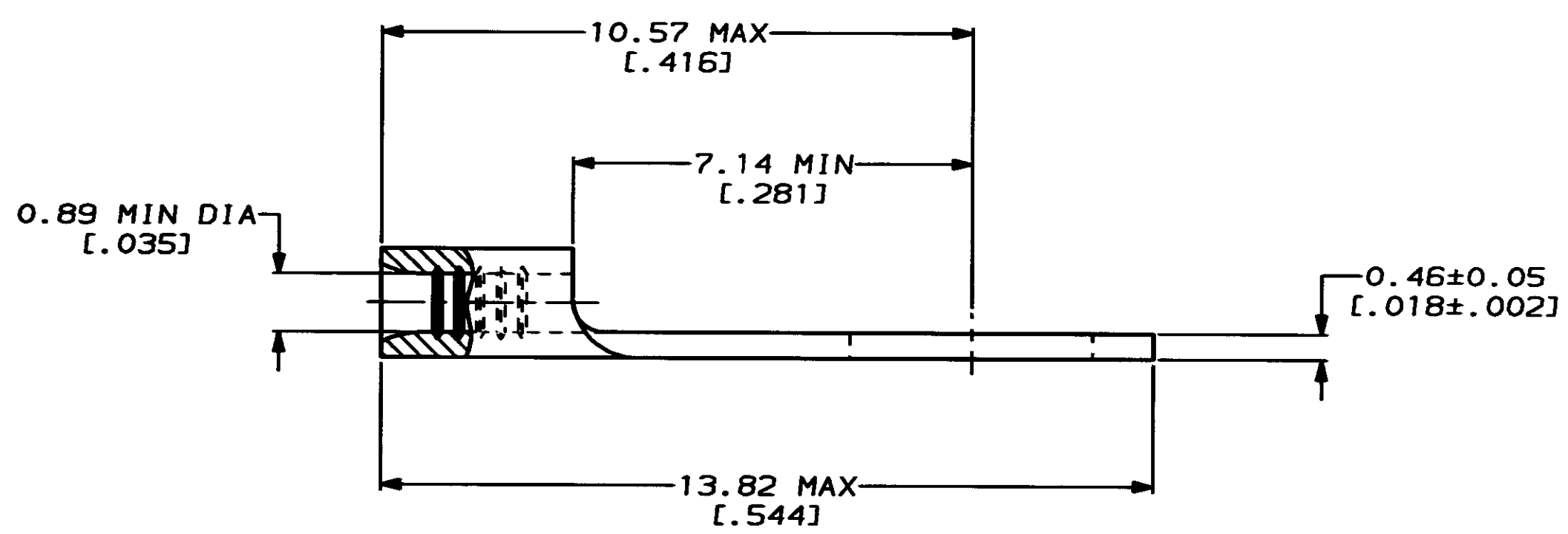

32858  
 PART NO

**AMP INCORPORATED**  
**CUSTOMER SERVICE SYSTEMS**

FOR ADDITIONAL PRODUCT INFORMATION OR COPIES OF DRAWINGS AND TECHNICAL DOCUMENTS	PRODUCT INFORMATION CENTER 1-800-522-6752
FOR APPLICATION TOOLING INFORMATION	TOOLING ASSISTANCE CENTER 1-800-722-1111
FOR ORDER ENTRY	1-800-526-5142

MAX RECOMMENDED OPERATING  
 TEMPERATURE:  
 170°C MAX

VOLTAGE RATING:  
 NOT APPLICABLE

WIRE CROSS SECTIONAL AREA RANGE:  
 0.1-0.41mm<sup>2</sup> [202-810] CIR MILS  
 STRANDED

THIS DRAWING IS A CONTROLLED DOCUMENT FOR  
 AMP INCORPORATED. IT IS SUBJECT TO CHANGE  
 AND THE CONTROLLING ENGINEERING ORGANIZATION  
 SHOULD BE CONTACTED FOR THE LATEST REVISION.

DO NOT SCALE PRINT.  
 UNLESS SPECIFIED  
 DIMENSIONS IN mm [INCHES]  
 TOLERANCES ON:  
 2 PLC DEC ± -  
 3 PLC DEC ± -  
 ANGLES ± -

MATERIAL  
 COPPER PER  
 ASTM B-152  
 ANNEALED

FINISH  
 TIN PLATE  
 0.00254 [.000100] MIN  
 THK PER MIL-T-10727

DR 2-2-93 TA BRINKMAN
CHK 2-2-93 DA PATTERSON
APPD 2-2-93 DE MILLER
APPD 2-2-93 JL HECKLEY
PRODUCT SPEC -
APPLICATION SPEC -
WEIGHT -

**AMP** AMP Incorporated  
 Harrisburg, PA 17105-3608

NAME  
**TERMINAL, RING  
 TONGUE, BUDGET**

SIZE C	CAGE CODE 00779	DRAWING NO C-32858
SCALE 10:1	SHEET 1 OF 1	

单击下面可查看定价，库存，交付和生命周期等信息

[>>TE Connectivity\(泰科\)](#)