

THIS DRAWING IS UNPUBLISHED. RELEASED FOR PUBLICATION  
 © COPYRIGHT - By - ALL RIGHTS RESERVED.

LOC	DIST	REVISIONS			
P	LTR	DESCRIPTION	DATE	DWN	APVD
G	14				
	K2	REVISED PER ECO-11-004917	11MAR11	RK	HMR

<b>AMP</b> WIRE RANGE	Listed	LR7189 Certified
16-14 AWG SOLID OR STRANDED	16-14 AWG SOLID OR STRANDED	16-14 AWG SOLID OR STRANDED

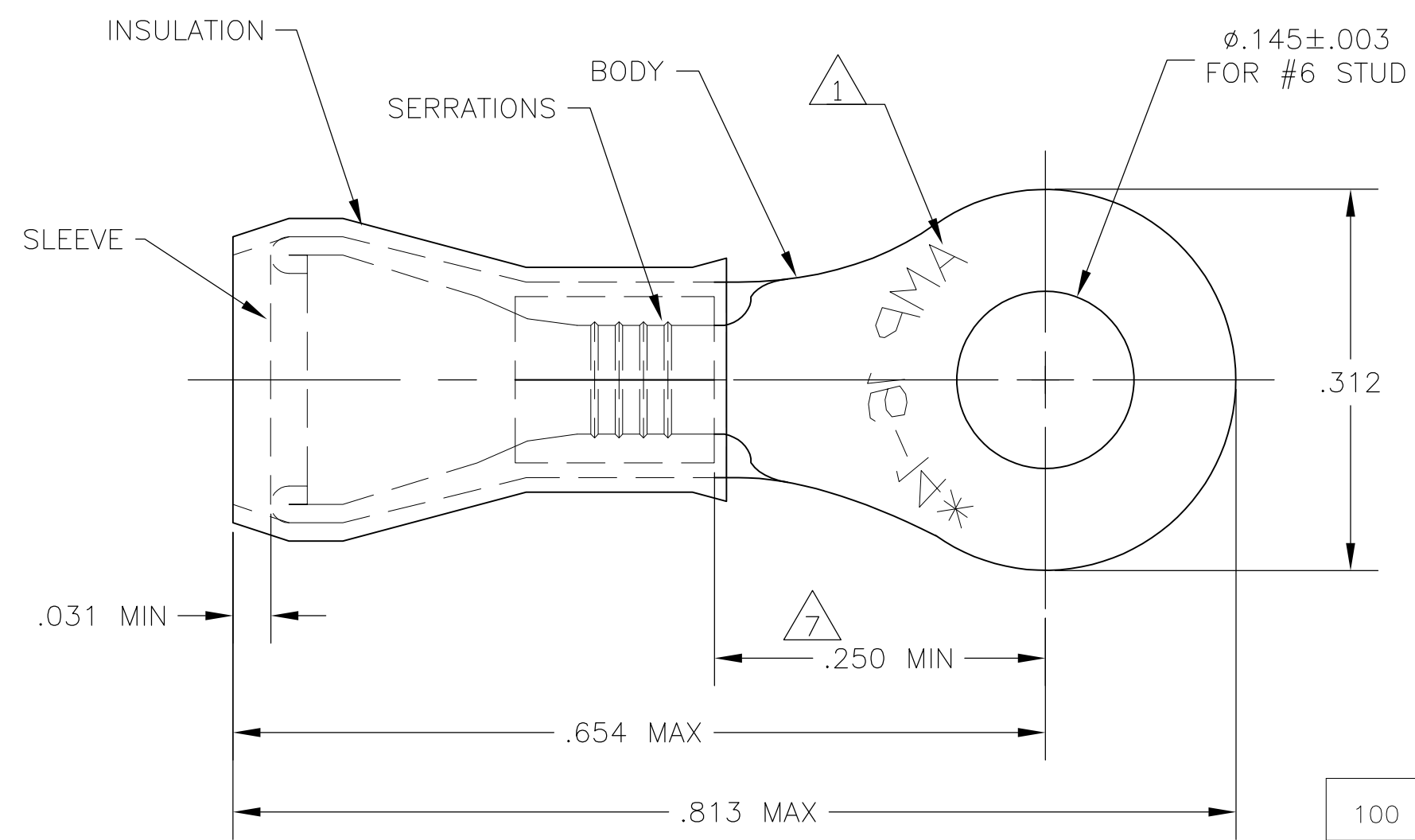

- 1 STAMP AMP 16-14\*, APPROX AS SHOWN.
- 2 TONGUE THICKNESS IS  $.031 \pm .002$
- 3 FOR  $.115-.170$  WIRE INSULATION DIA
- 4 MAX RECOMMENDED OPERATING TEMP IS 105°C.
- 5 300 VOLT MAX RATING.
- 6 WIRE CROSS SECTIONAL AREA RANGE  $1.04-2.62\text{mm}$  [2,050-5,180 CIR MILS]
- 7 APPLIES FROM EDGE OF METAL WIRE BBL TO CENTER OF STUD HOLE.
- 8 RESTRICTED PART: AMP GREAT BRITIAN LTD, USE ONLY.

100	LOOSE PIECE, BOX	BODY & SLEEVE: COPPER PER ASTM B152 TIN PL. PER ASTM B-545 INSULATION: NYLON, TYPE I, PER ASTM D4066 COLOR: BLUE	8-326882-1
5000	ON TAPE, REEL		2-326882-1
			<del>326882-1</del>
1000	LOOSE PIECE		326882
QTY	PACKAGING	MATERIAL / FINISH	PART NO

OBSOLETE

THIS DRAWING IS A CONTROLLED DOCUMENT.		DWN jr_ruth 02MAR10	TE Connectivity	
DIMENSIONS: INCHES		CHK T MICHELUTTI 02MAR10		
TOLERANCES UNLESS OTHERWISE SPECIFIED:		APVD T MICHELUTTI 02MAR10	NAME	
0 PLC ± -		PRODUCT SPEC	WIRE TERMINAL	
1 PLC ± -		UL486B	PIDG, RING TONGUE	
2 PLC ± -		APPLICATION SPEC	WIRE SIZE: 16-14	
3 PLC ± .008		114-2157	SIZE	CAGE CODE
4 PLC ± -		WEIGHT -	A3	00779
ANGLES ± 1°		CUSTOMER DRAWING	DRAWING NO	RESTRICTED TO
MATERIAL SEE TABLE	FINISH SEE TABLE		G-326882	
		SCALE 8:1	SHEET 1 OF 1	REV K2

单击下面可查看定价，库存，交付和生命周期等信息

[>>TE Connectivity\(泰科\)](#)