

LOC		DIST		REVISIONS			
P	LTR	DESCRIPTION	DATE	DNW	APVD		
M		REV PER ECO 15-001580	3-9-15	CT	CT		

- THIS RECEPTACLE WILL MATE WITH ANY SIZE 4, 62 POSN. PLUG IN AMPLIMITE SERIES.
  - CONNECTOR SUPPLIED WITHOUT CONTACTS; SHOWN FOR ILLUSTRATION ONLY.
  - BE-CU RETENTION CLIPS ARE INCLUDED IN INSERT AND INSTALLED WITH TINES POINTING TOWARDS MATING FACE.
  - OVERALL DIMENSIONS DO NOT INCLUDE RAISED CAVITY IDENTIFICATION.
- ⚠ MARKING FAR SIDE REFERS TO WIDE SIDE OF KEYSTONE. NEAR SIDE REFERS TO NARROW SIDE OF KEYSTONE  
 ⚠ 100% INSPECTION REQUIRED PER BOEING 1B01:  
 A. VISUAL  
 B. DWV  
 C. IR  
 ⚠ CUSTOMER REQUIRES SINGLE LOT DATE CODE.  
 ⚠ SPECIAL REQUIREMENTS:  
 A. TEST TWO CONNECTORS PER LOT FOR COMPLIANCE TO GROMMET PEEL STRENGTH REQUIREMENTS.  
 B. TEST ALL CIRCUIT CAVITIES FOR MISALIGNMENT OR EXCESSIVE ADHESIVE.

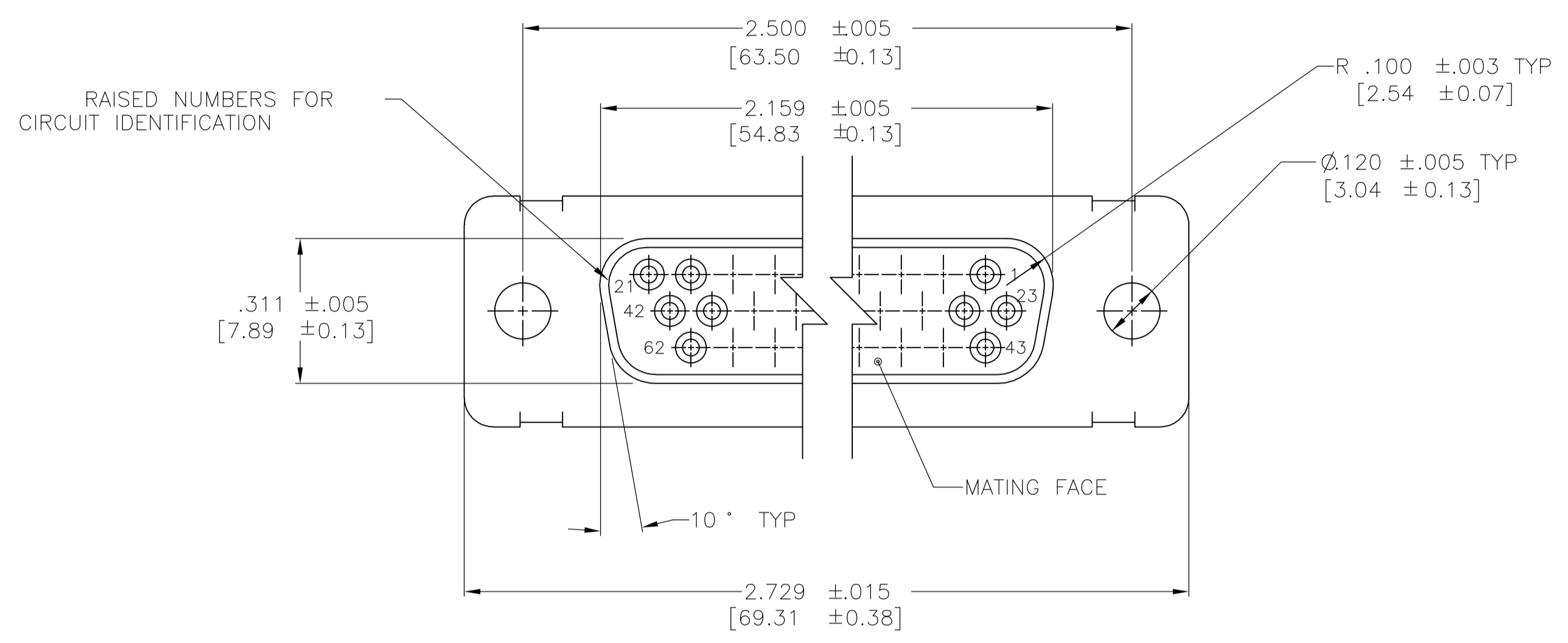

⚠ FOR (-2, -4 & -7) MARK MFG'S NAME, BRAND OR LOGO AND DATE CODE FAR SIDE. CUSTOMER P/N MARKED NEAR SIDE

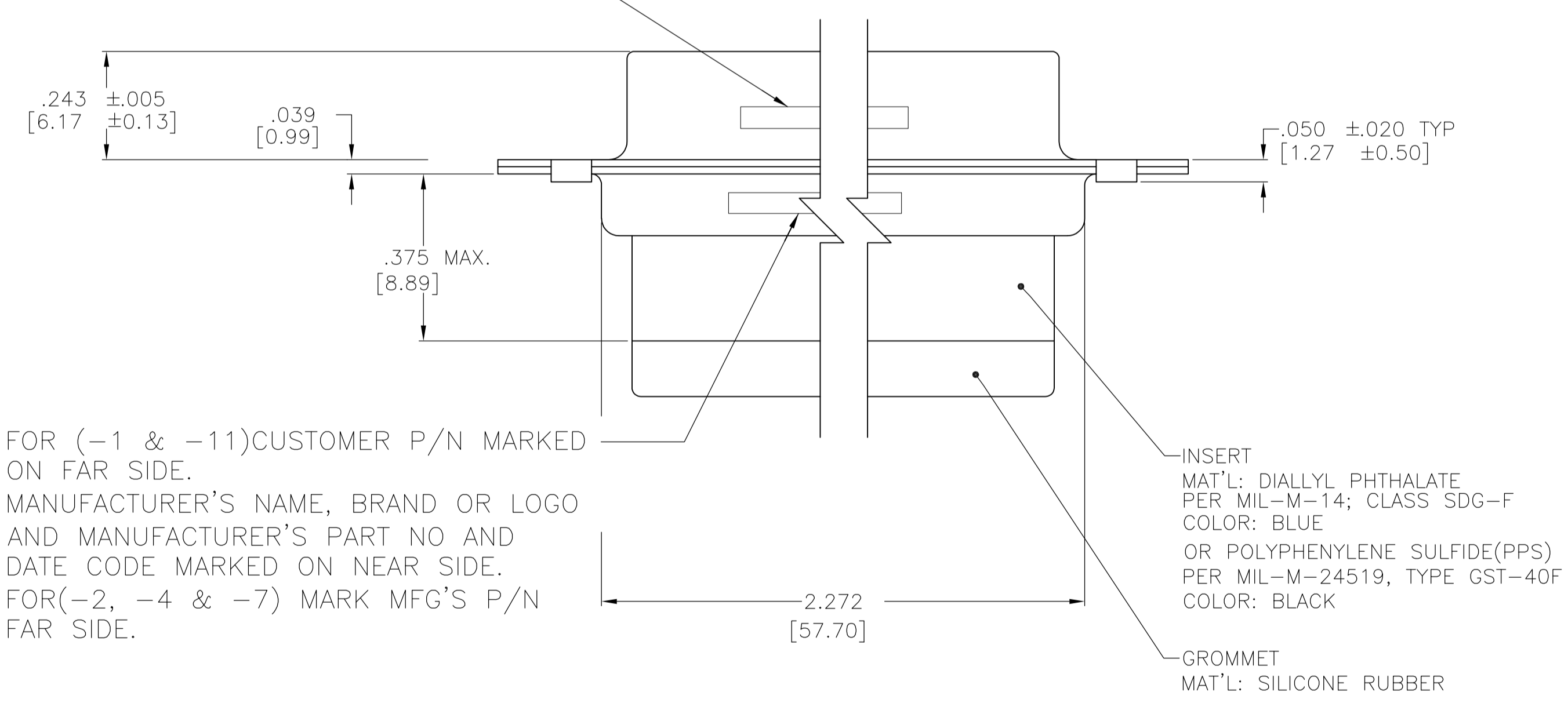

⚠ FOR (-1 & -11) CUSTOMER P/N MARKED ON FAR SIDE. MANUFACTURER'S NAME, BRAND OR LOGO AND MANUFACTURER'S PART NO AND DATE CODE MARKED ON NEAR SIDE. FOR (-2, -4 & -7) MARK MFG'S P/N FAR SIDE.

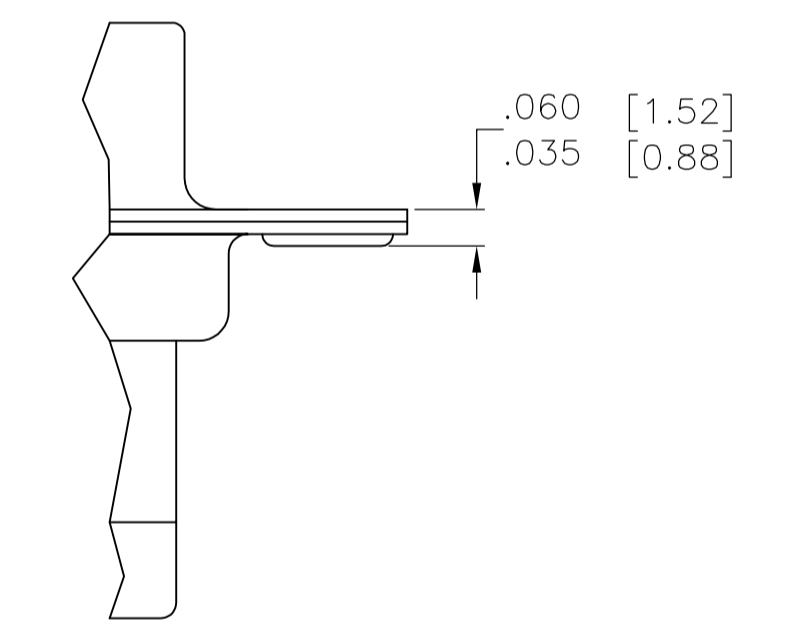
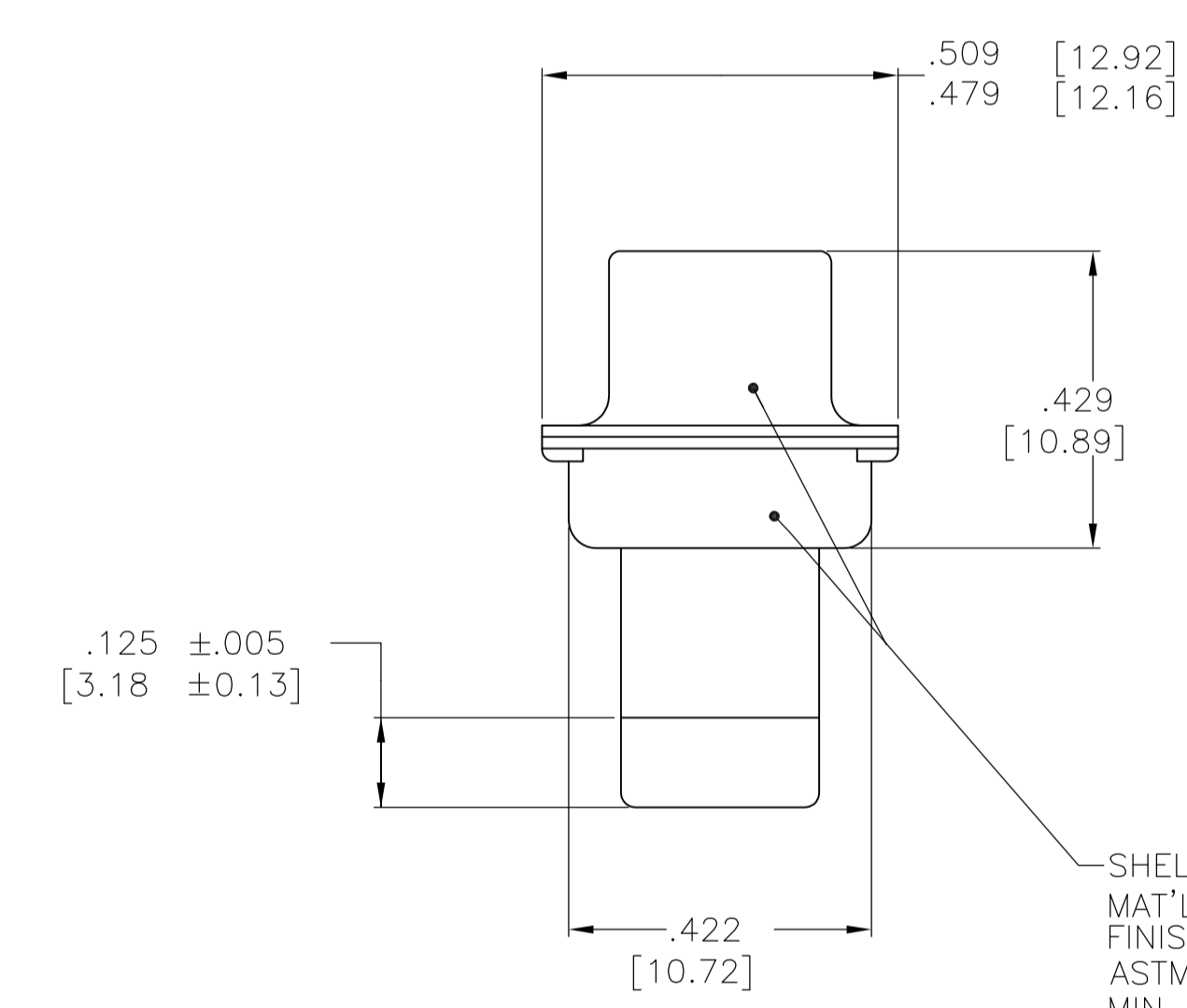

REMARKS	CUSTOMER PART NO.	PART NO.
⚠	1B01-028RHW	1-211670-1
⚠	B010648-0008	211670-7
⚠	-	211670-4
⚠	2A065-022V-001	211670-2
⚠	1B01-028	211670-1

THIS DRAWING IS A CONTROLLED DOCUMENT.

DIMENSIONS: INCHES	TOLERANCES UNLESS OTHERWISE SPECIFIED:	DIN C.C. THOMAS 4-3-90	APVD R. GILMAN 8-31-92
0 PLC ± -	1 PLC ± -	NAME F. KINSEY 8-31-92	PRODUCT SPEC
2 PLC ± -	3 PLC ± .010 (0.25)	APPLICATION SPEC	SIZE CASE CODE DRAWING NO
4 PLC ± -	ANGLES ± ± 0° 30'	WEIGHT	A1 00779 C=211670
MATERIAL SEE CALLOUTS	FINISH SEE CALLOUTS	CUSTOMER DRAWING	SCALE 4:1 SHEET 1 OF 1 REV M

THIS DRAWING IS A CONTROLLED DOCUMENT.  
 C.C. THOMAS 4-3-90  
 R. GILMAN 8-31-92  
 F. KINSEY 8-31-92  
 NAME  
 PRODUCT SPEC  
 APPLICATION SPEC  
 SIZE CASE CODE DRAWING NO  
 WEIGHT  
 CUSTOMER DRAWING  
 SCALE 4:1 SHEET 1 OF 1 REV M

**STE** TE Connectivity  
 RCPT. ASS'Y, AMPLIMITE, 62 POSN., SIZE 4, SERIES 90, NON-MAGNETIC WITH GROMMET

单击下面可查看定价，库存，交付和生命周期等信息

[>>TE Connectivity\(泰科\)](#)