

REVISIONS				
P.	LTN.	DESCRIPTION	DATE	APVD.
A		RELEASED PER ECO-19-014774	26SEP2019	CJV JW

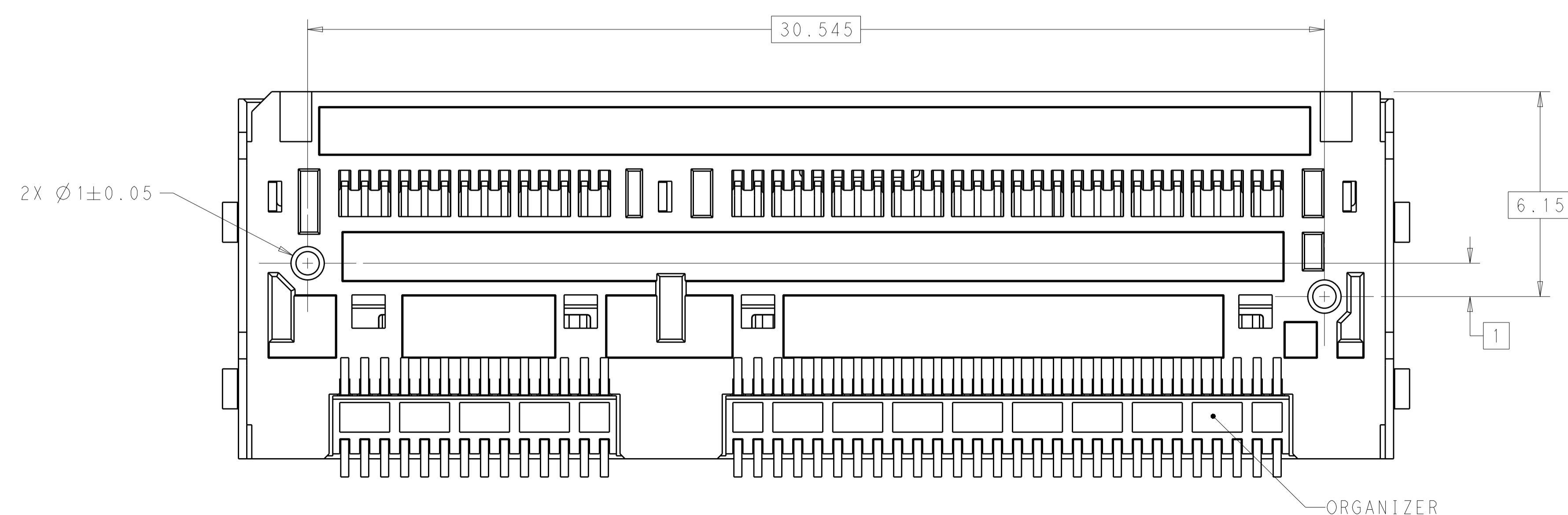

- 1 HOUSING, ORGANIZERS, CONTACT OVERMOLDS - LCP, UL94V-0, BLACK. SHELL, CONTACTS AND HOLD DOWNS - COPPER ALLOY.
- 2 CONTACTS - GOLD PLATE ON MATING SURFACES, TIN PLATE ON SOLDER FEET. HOLD DOWNS - TIN PLATE. SHELL - NICKEL PLATE, TIN PLATE ON HOLD DOWNS
- 3 DATUMS AND BASIC DIMENSIONS ESTABLISHED BY CUSTOMER.
- 4. MINIMUM HOST PCB THICKNESS: 1.5
- 5 SEE MSA SPECIFICATION FOR ADDITIONAL PADDLE CARD LAYOUTS COMPATIBLE WITH THIS RECEPTACLE AND FOR OPTIONAL SPLIT CONTACT PAD LAYOUTS FOR THE PADDLE CARD. SPECIFICATION PINOUT MAY ALSO DESIGNATE PAD SEQUENCE DIFFERENT FROM ILLUSTRATION.
- 6 POSITIONS DESIGNATED AS "SIGNAL" ARE REQUIRED LOCATIONS FOR HIGH SPEED DIFFERENTIAL PAIR SIGNALING. THESE LOCATIONS MAY ALSO BE USED FOR SUPPORTING SIDEBAND SIGNALS OR OTHER UTILITY PURPOSES. POSITIONS DESIGNATED AS "GROUND" ARE REQUIRED WHEN SUPPORTING HIGH SPEED DIFFERENTIAL SIGNALS. THESE LOCATIONS MAY ALSO BE USED FOR SIDEBAND SIGNALS OR OTHER UTILITY PURPOSES.
- 7 COMPONENT AND TRACES KEEP OUT AREA. EACH EDGE 0.15 MIN FROM EDGE OF HOLE.
- 8 TAPE AND REEL PACKAGED FOR PICK AND PLACE SURFACE MOUNT PROCESSING, SEE FIGURE 1. POCKET TAPE WIDTH = 56.

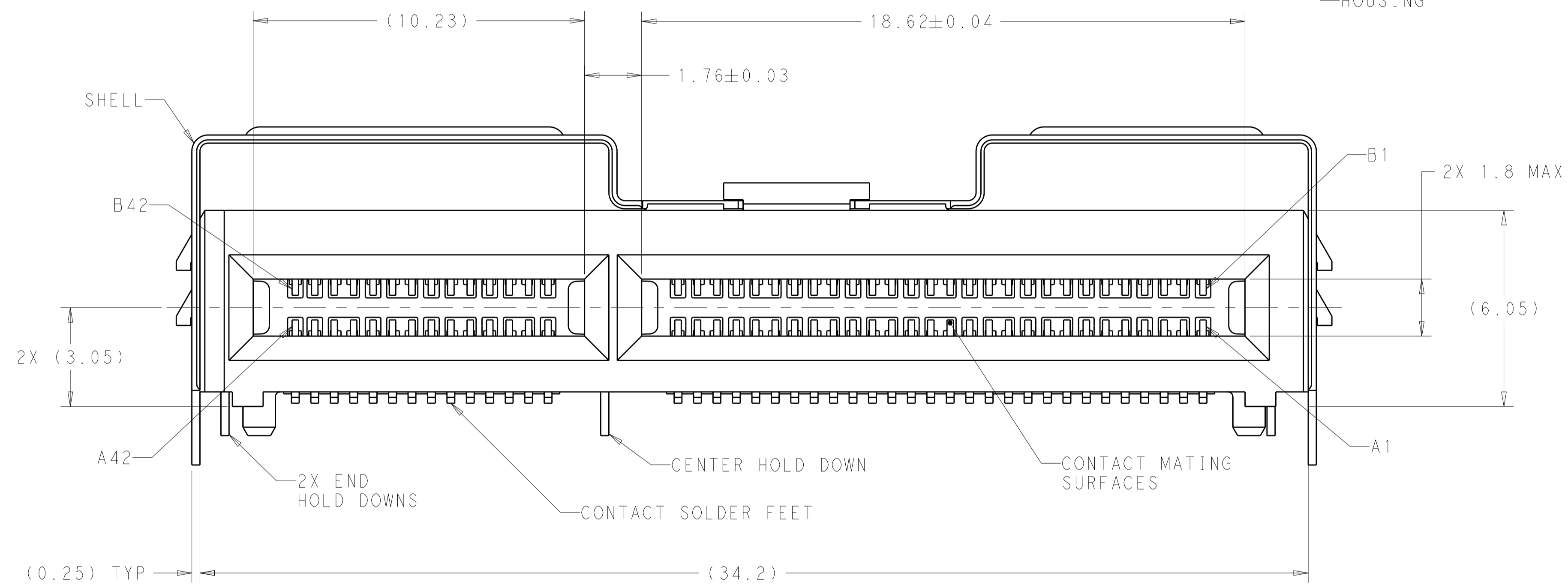
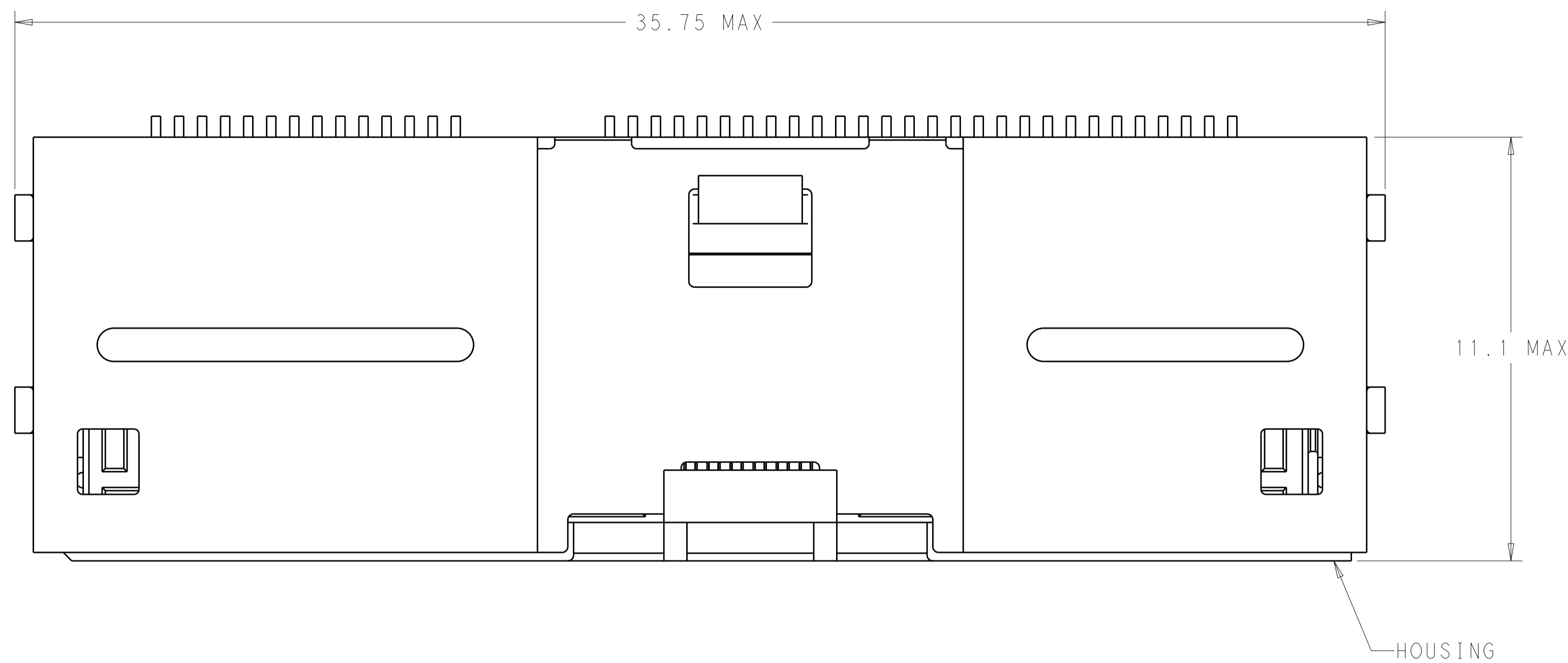
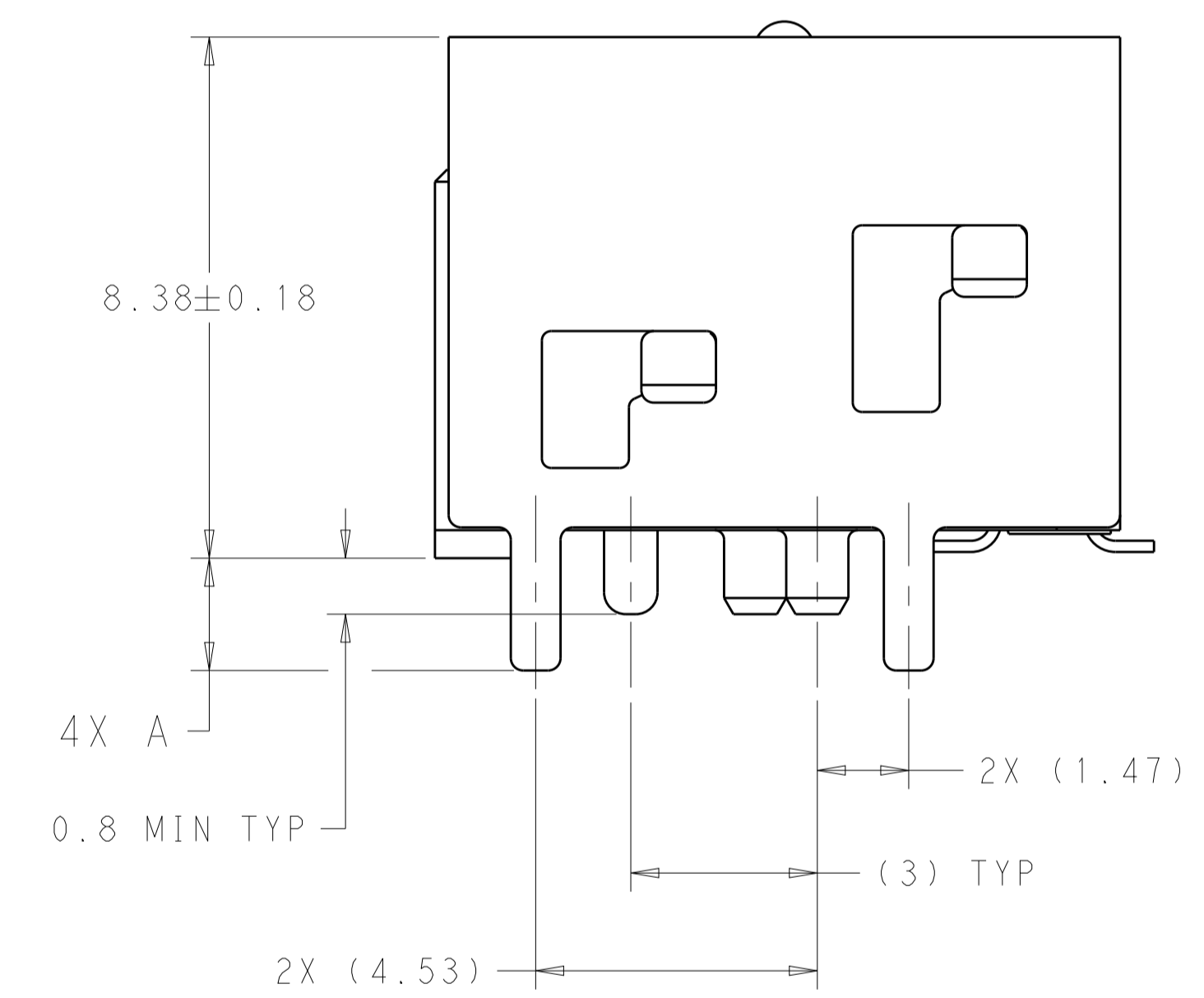

SEE SHEET 4 FOR PART TABLE

THIS DRAWING IS A CONTROLLED DOCUMENT.		OWN: B. MATTHEWS 12MAR2018	TE Connectivity
DIMENSIONS: mm		CHK: D. HARMON 12MAR2018	
TOLERANCES UNLESS OTHERWISE SPECIFIED:		APVD: D. HARMON 12MAR2018	NAME: RECEPTACLE ASSEMBLY, RIGHT ANGLE, 84 POSITION, SLIVER 2.0
0 PLC ±	1 PLC ±	PRODUCT SPEC: 108-130021	SIZE: A1
2 PLC ±	3 PLC ±	APPLICATION SPEC: 114-130015	CAGE CODE: -
4 PLC ±	ANGLES ±	WEIGHT: -	DRAWING NO: C=2331814
MATERIAL: △	FINISH: △	CUSTOMER DRAWING	RESTRICTED TO: -
SCALE: 10:1			SHEET: 1 OF 4
			REV: A

REVISIONS				
P.	LTM	DESCRIPTION	DATE	APVD
-	-	SEE SHEET 1	-	-

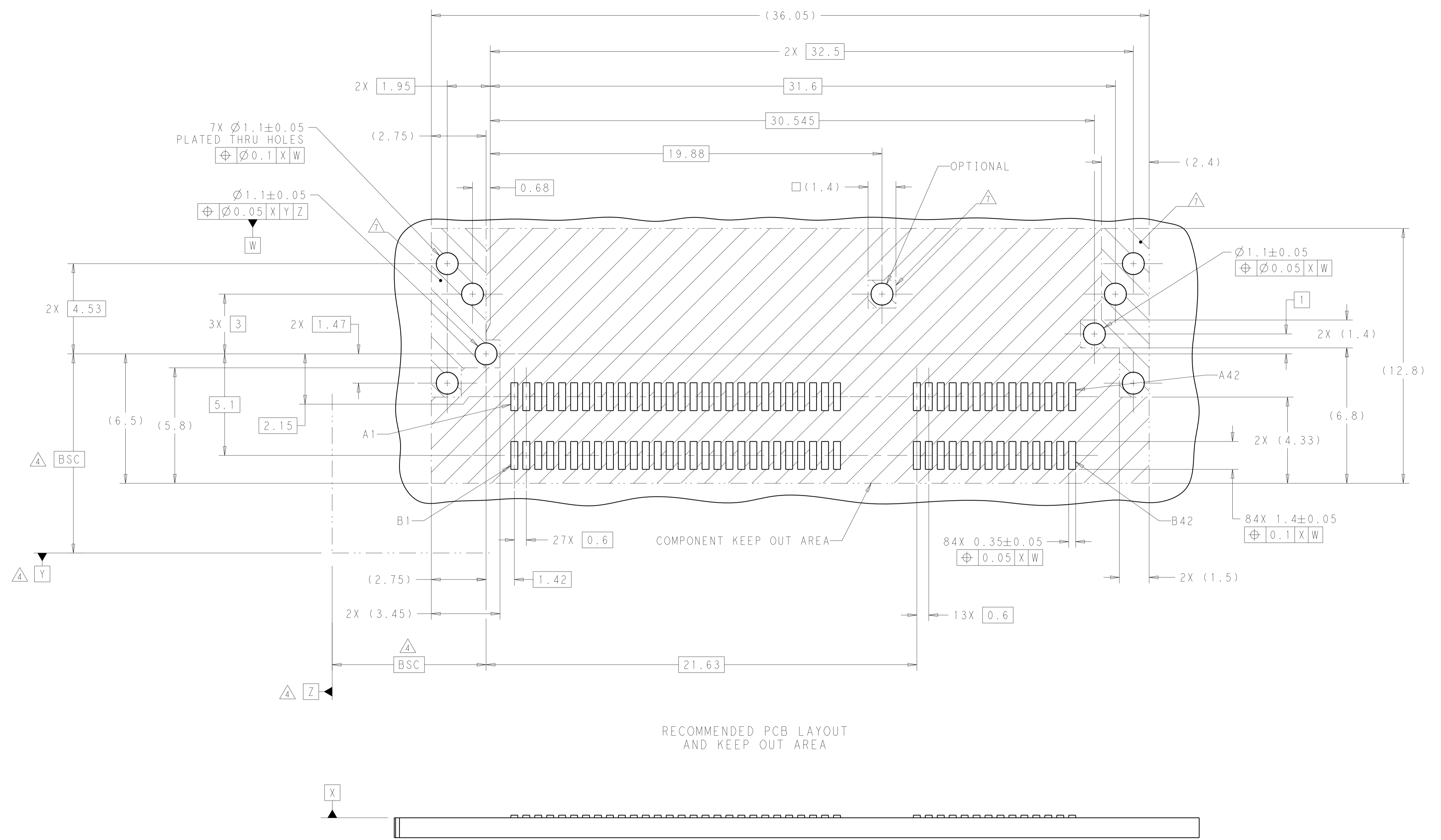

RECOMMENDED PCB LAYOUT
 AND KEEP OUT AREA

THIS DRAWING IS A CONTROLLED DOCUMENT.		DWN: B. MATTHEWS 12MAR2018	TE Connectivity
DIMENSIONS: mm		CHK: D. HARMON 12MAR2018	
TOLERANCES UNLESS OTHERWISE SPECIFIED:		APVD: D. HARMON 12MAR2018	NAME: RECEPTACLE ASSEMBLY, RIGHT ANGLE, 84 POSITION, SLIVER 2.0
0 PLC ±	1 PLC ±	PRODUCT SPEC: 108-130021	SIZE: A1
2 PLC ±	3 PLC ±	APPLICATION SPEC: 114-130015	CAGE CODE: -
4 PLC ±	ANGLES ±	WEIGHT: -	DRAWING NO: C=2331814
MATERIAL: FINISH: -		CUSTOMER DRAWING	RESTRICTED TO: -
SCALE: 1:1			SHEET: 2 OF 4
			REV: A

REVISIONS				
P.	LTN.	DESCRIPTION	DATE	APVD.
-	-	SEE SHEET 1	-	-

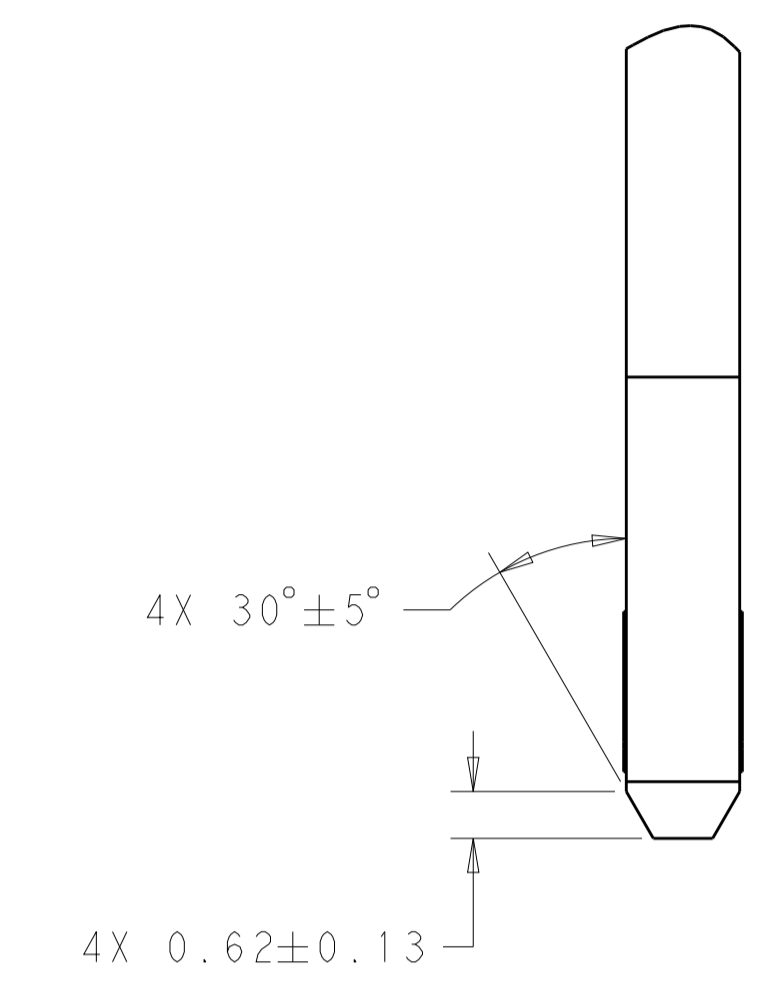
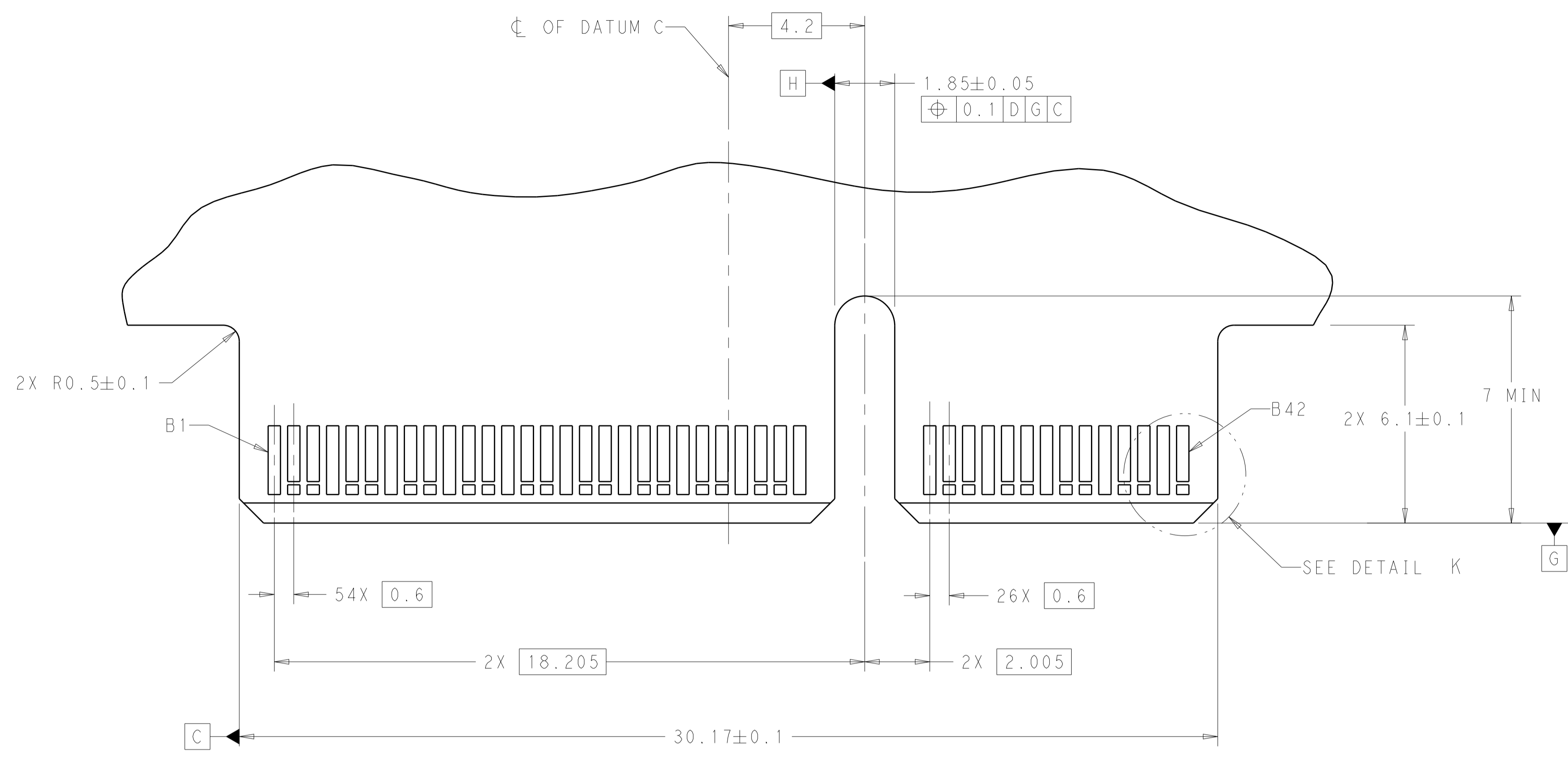

RECOMMENDED PCB OUTLINE DIMENSIONS
 TOLERANCE VALUES ARE CRITICAL. PLEASE BE SURE TO DESIGNATE
 TOLERANCES TO PCB SUPPLIER TO ENSURE OPTIMIZED FUNCTIONALITY

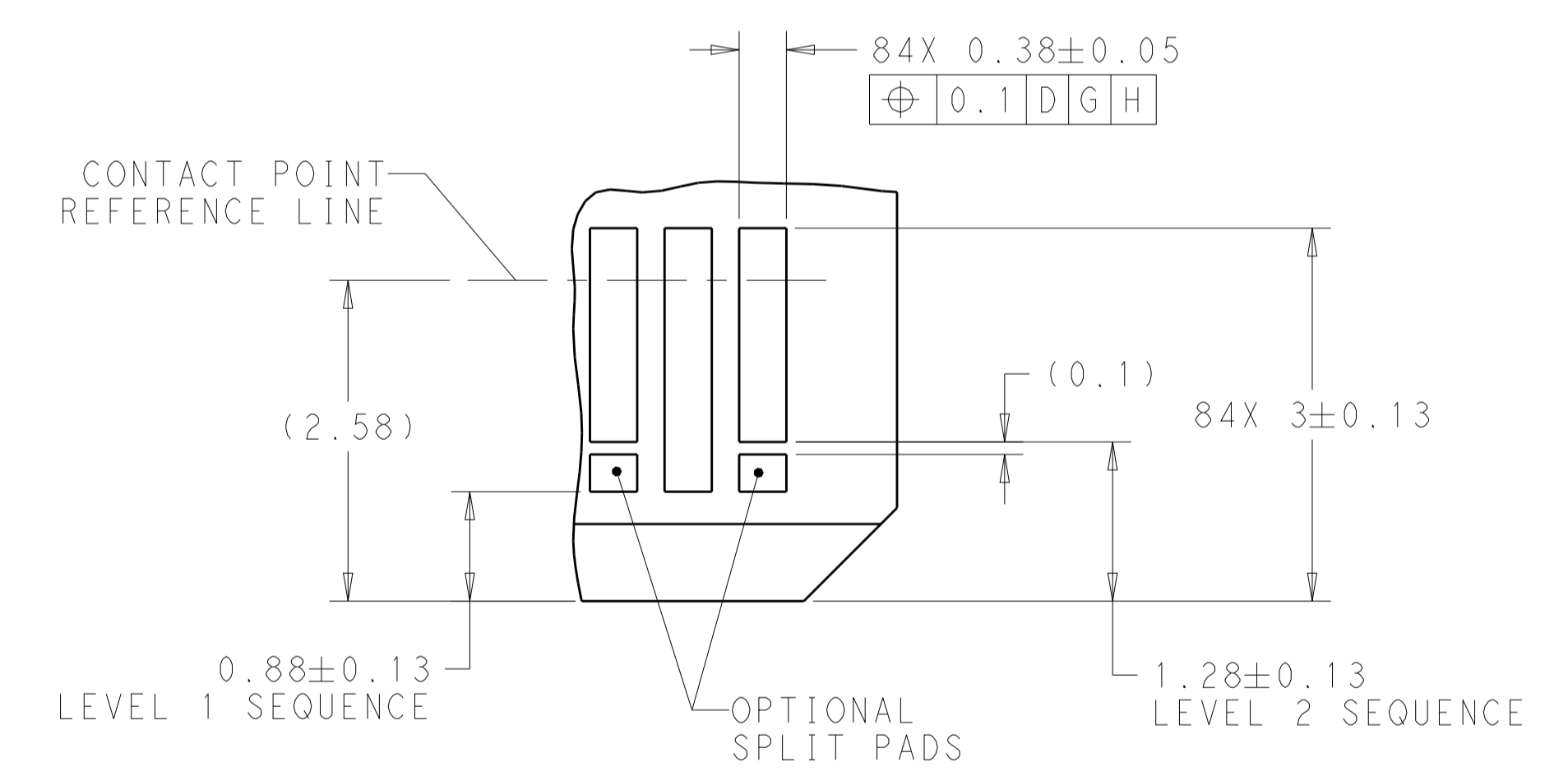
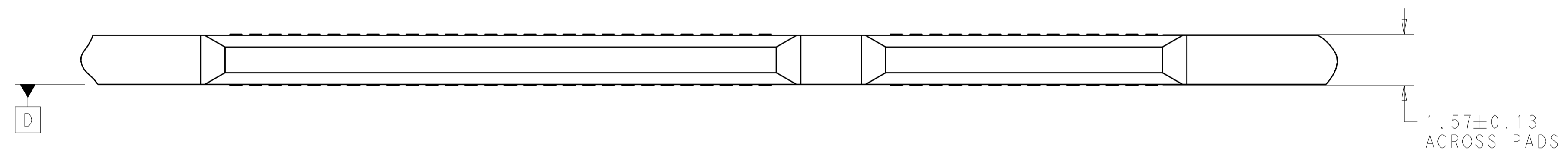

5 DETAIL K
 SCALE 20:1

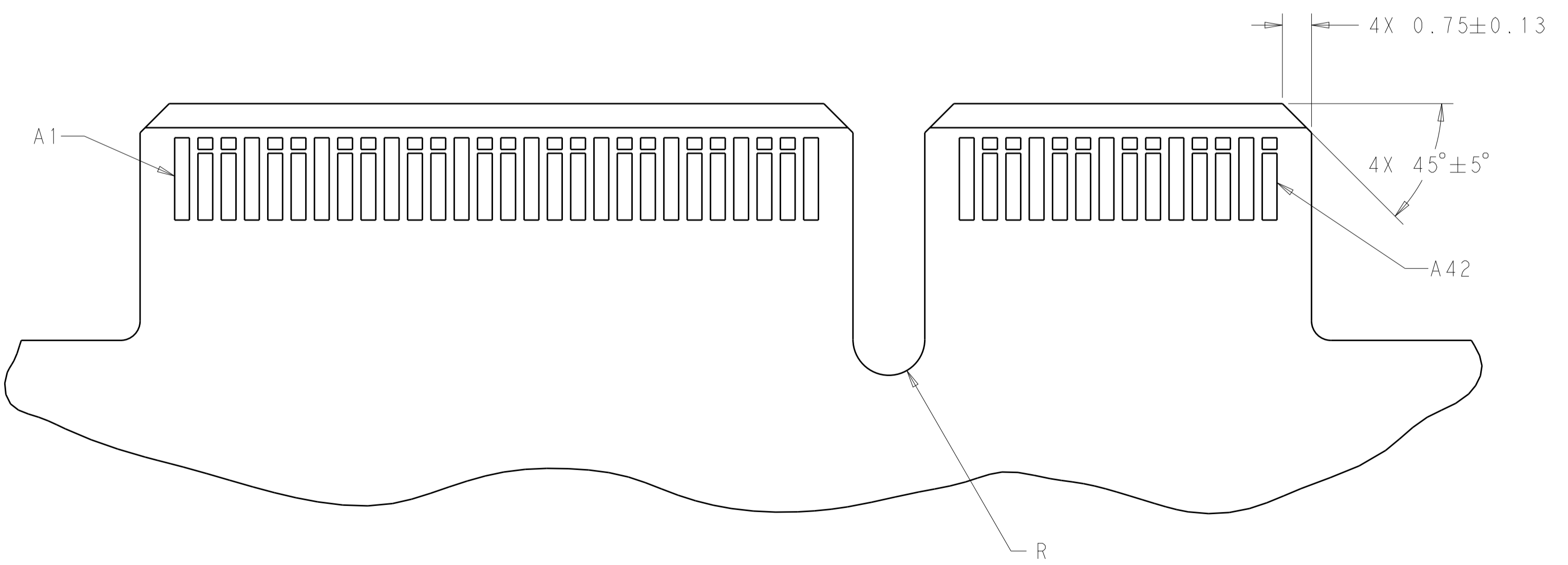

THIS DRAWING IS A CONTROLLED DOCUMENT.		OWN: B. MATTHEWS 12MAR2018	TE Connectivity
DIMENSIONS: mm		CHK: D. HARMON 12MAR2018	
TOLERANCES UNLESS OTHERWISE SPECIFIED:		APVD: D. HARMON 12MAR2018	NAME: RECEPTACLE ASSEMBLY, RIGHT ANGLE, 84 POSITION, SLIVER 2.0
0 PLC ±	1 PLC ±	PRODUCT SPEC: 108-130021	SIZE: A1
2 PLC ±	3 PLC ±	APPLICATION SPEC: 114-130015	CAGE CODE: -
4 PLC ±	ANGLES ±	WEIGHT: -	DRAWING NO: C=2331814
MATERIAL: -	FINISH: -	CUSTOMER DRAWING	RESTRICTED TO: -
SCALE: 1:1			SHEET: 3 OF 4
REV: A			

REVISIONS					
P.	LTN	DESCRIPTION	DATE	OWN	APVD
-	-	SEE SHEET 1	-	-	-

TABLE 1: CONNECTOR CONTACT IDENTIFICATION \triangle 5/6

CONTACT NUMBER	SIDE A	SIDE B
1	GROUND	GROUND
2	SIGNAL	SIGNAL
3	SIGNAL	SIGNAL
4	GROUND	GROUND
5	SIGNAL	SIGNAL
6	SIGNAL	SIGNAL
7	GROUND	GROUND
8	SIGNAL	SIGNAL
9	SIGNAL	SIGNAL
10	GROUND	GROUND
11	SIGNAL	SIGNAL
12	SIGNAL	SIGNAL
13	GROUND	GROUND
14	SIGNAL	SIGNAL
15	SIGNAL	SIGNAL
16	GROUND	GROUND
17	SIGNAL	SIGNAL
18	SIGNAL	SIGNAL
19	GROUND	GROUND
20	SIGNAL	SIGNAL
21	SIGNAL	SIGNAL
22	GROUND	GROUND
23	SIGNAL	SIGNAL
24	SIGNAL	SIGNAL
25	GROUND	GROUND
26	SIGNAL	SIGNAL
27	SIGNAL	SIGNAL
28	GROUND	GROUND
29	GROUND	GROUND
30	SIGNAL	SIGNAL
31	SIGNAL	SIGNAL
32	GROUND	GROUND
33	SIGNAL	SIGNAL
34	SIGNAL	SIGNAL
35	GROUND	GROUND
36	SIGNAL	SIGNAL
37	SIGNAL	SIGNAL
38	GROUND	GROUND
39	SIGNAL	SIGNAL
40	SIGNAL	SIGNAL
41	GROUND	GROUND
42	GROUND	GROUND

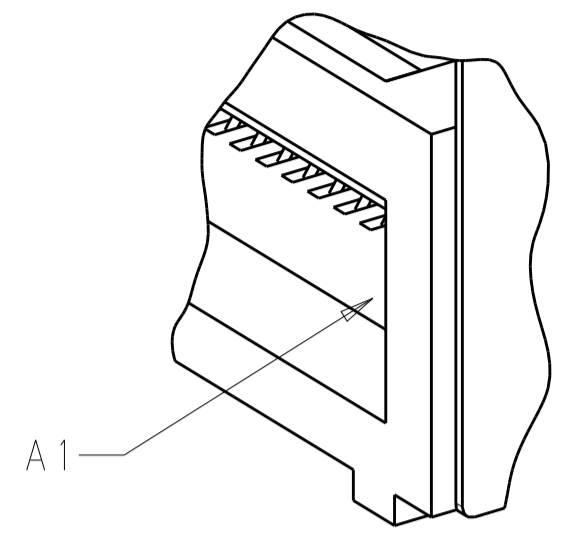

DETAIL B
SCALE 10:1

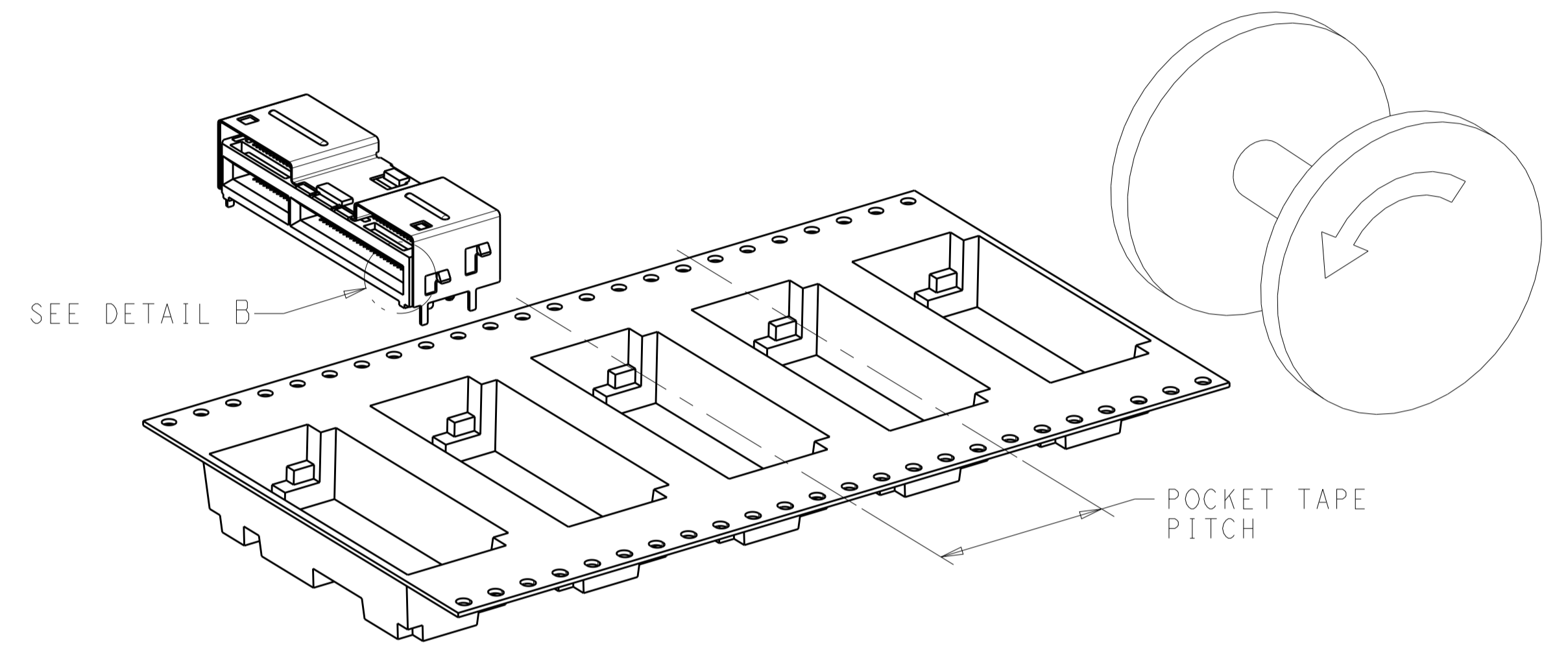

FIGURE 1 \triangle
DIRECTION OFF TOP OF REEL
FOR USER UNREELING
SCALE 2:1

1.2±0.2	ALL	0.76µm Au	24	300	200	1-2331814-9
		0.38µm Au			100	1-2331814-8
		FLASH Au/PdNi			50	1-2331814-7
1.8 +0.2/-0.1	ENDS	0.76µm Au	24	300	200	1-2331814-6
		0.38µm Au			100	1-2331814-5
		FLASH Au/PdNi			50	1-2331814-4
1.8 +0.2/-0.1	ALL	0.76µm Au	24	300	200	1-2331814-3
		0.38µm Au			100	1-2331814-2
		FLASH Au/PdNi			50	1-2331814-1
1.2±0.2	ALL	0.76µm Au	20	350	200	2331814-9
		0.38µm Au			100	2331814-8
		FLASH Au/PdNi			50	2331814-7
1.8 +0.2/-0.1	ENDS	0.76µm Au	20	350	200	2331814-6
		0.38µm Au			100	2331814-5
		FLASH Au/PdNi			50	2331814-4
1.8 +0.2/-0.1	ALL	0.76µm Au	20	350	200	2331814-3
		0.38µm Au			100	2331814-2
		FLASH Au/PdNi			50	2331814-1
A	HOLD DOWNS	PLATING	POCKET TAPE PITCH	REEL QUANTITY	MATING CYCLES	PART NUMBER

THIS DRAWING IS A CONTROLLED DOCUMENT.

OWN: B. MATTHEWS 12MAR2018
 CHK: D. HARMON 12MAR2018
 APVD: D. HARMON 12MAR2018

DIMENSIONS: mm
 TOLERANCES UNLESS OTHERWISE SPECIFIED:
 0 PLC ±
 1 PLC ±
 2 PLC ±
 3 PLC ±
 4 PLC ±
 ANGLES ±
 MATERIAL FINISH

PRODUCT SPEC: 108-130021
 APPLICATION SPEC: 114-130015
 WEIGHT: -

NAME: RECEPTACLE ASSEMBLY, RIGHT ANGLE, 84 POSITION, SLIVER 2.0
 SIZE: A1
 CAGE CODE: -
 DRAWING NO: C=2331814
 RESTRICTED TO: -

CUSTOMER DRAWING SCALE 10:1 SHEET 4 OF 4 REV A

单击下面可查看定价，库存，交付和生命周期等信息

[>>TE Connectivity\(泰科\)](#)