

THIS DRAWING IS UNPUBLISHED. RELEASED FOR PUBLICATION  
 © COPYRIGHT - By - ALL RIGHTS RESERVED.

LOC	DIST	REVISIONS			
P	LTR	DESCRIPTION	DATE	DWN	APVD
		K3	REVISED PER ECO-13-000473	18JUL13	KH DR

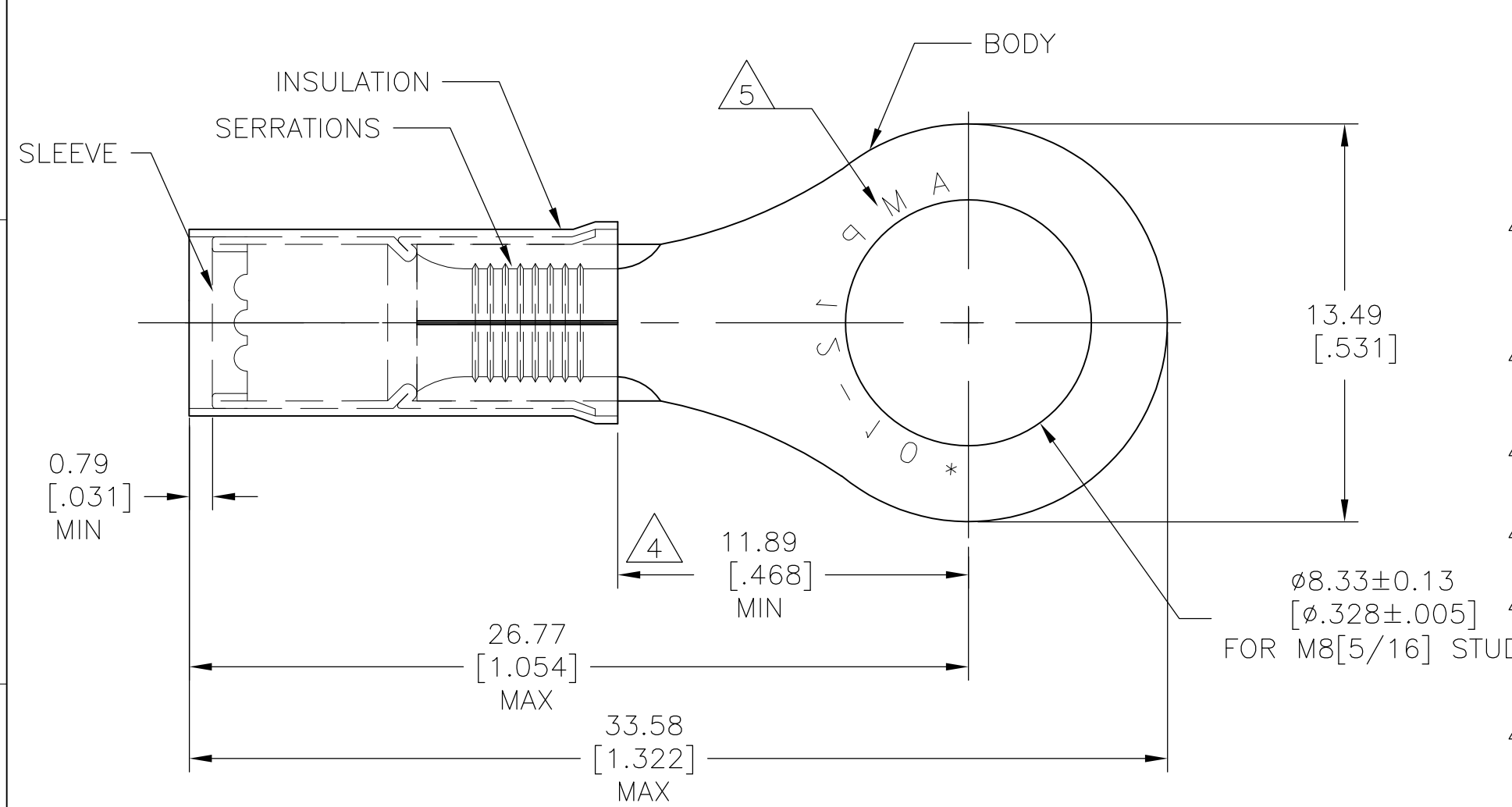

<b>AMP</b> WIRE RANGE	Listed FILE E13288	LR7189 Certified
12-10 AWG SOLID OR STRANDED	12-10 AWG SOLID OR STRANDED	12-10 AWG SOLID OR STRANDED

- 1 FOR WIRE INSULATION DIA: 3.81[.150] TO 6.35[.250]
- 2 TONGUE MATERIAL THK: 1.02±0.05[.040±.002]
- 3 ALTERNATE PVC INSULATION MATERIAL FOR FOREIGN SUBSIDIARIES ONLY.
- 4 DIMENSION APPLIES FROM EDGE OF METAL WIRE BARREL TO CENTER OF STUD HOLE.
- 5 STAMP AMP 12-10\* APPROX AS SHOWN
- 6 MATERIAL:  
BODY&SLEEVE: COPPER PER ASTM B152  
INSULATION: NYLON. 3
- 7 FINISH:  
BODY&SLEEVE: TIN PLATE PER ASTM B545  
INSULATION: COLOR-YELLOW

-	100	LOOSE PC, BOX	8-35111-1
MS25036-113 CLASS 2	2500	ON TAPE, REEL	2-35111-1
MS25036-113 CLASS 1&2	500	LOOSE PIECE	35111
MILITARY PART NO& CLASS	QTY	PACKAGE TYPE	PART NO

**AMP INCORPORATED**  
**CUSTOMER SERVICE SYSTEMS**

FOR ADDITIONAL PRODUCT INFORMATION OR COPIES OF DRAWINGS AND TECHNICAL DOCUMENTS  
 PRODUCT INFORMATION CENTER  
 1-800-522-6752

FOR APPLICATION TOOLING INFORMATION  
 TOOLING ASSISTANCE CENTER  
 1-800-722-1111

FOR ORDER ENTRY  
 1-800-526-5142

RECOMMENDED OPERATING TEMPERATURE:  
 105°C [221°F]

VOLTAGE RATING:  
 300V MAX

WIRE CROSS SECTIONAL AREA RANGE:  
 2.62-6.64mm<sup>2</sup> [5,180-13,100]  
 SOLID OR STRANDED

THIS DRAWING IS A CONTROLLED DOCUMENT.

DIMENSIONS:  
 mm [INCHES]

TOLERANCES UNLESS OTHERWISE SPECIFIED:

0 PLC	± -
1 PLC	± -
2 PLC	± 0.20[.008]
3 PLC	± -
4 PLC	± -
ANGLES	± 5°

MATERIAL 6

FINISH 7

DWN KIRAN HOLAL 02APR12  
 CHK ROHDE DANIEL 02APR12  
 APVD ROHDE DANIEL 02APR12

**STE** TE Connectivity

NAME: WIRE TERMINAL  
 P.I.D.G RING TONGUE  
 WIRE SIZE: 12-10

SIZE: A3 CAGE CODE: 00779 DRAWING NO: C-35111 RESTRICTED TO: -

WEIGHT: -

CUSTOMER DRAWING SCALE: 5:1 SHEET: 1 OF 1 REV: K3

单击下面可查看定价，库存，交付和生命周期等信息

[>>TE Connectivity\(泰科\)](#)