

| REVISIONS | | | |
|-----------------|-------------|---------|----------|
| REV | DESCRIPTION | DATE | APPROVED |
| 01 ₀ | RELEASED | 6-28-89 | S.T.M. |

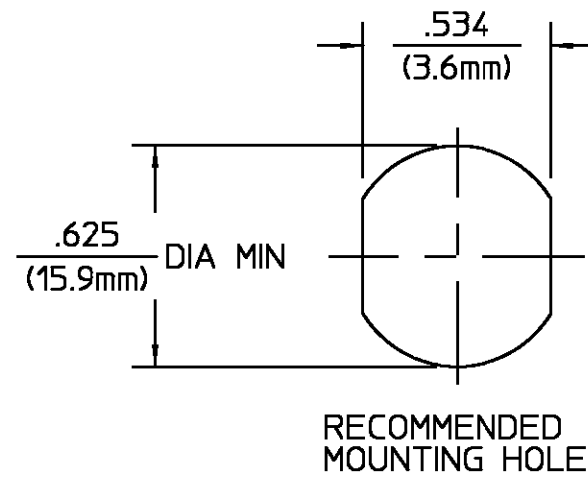
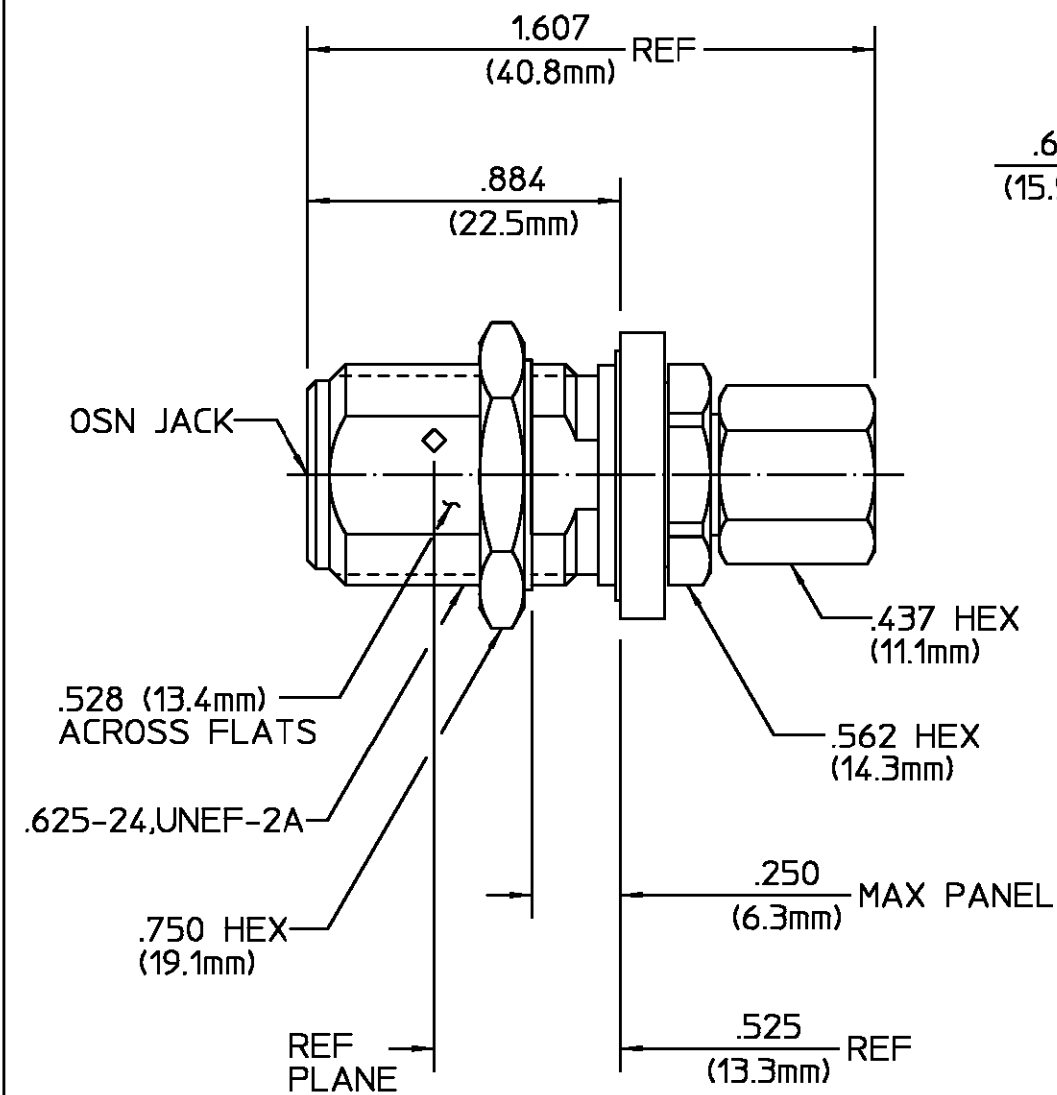

| COMPONENT | MATERIAL | FINISH |
|--|---|---|
| HOUSING CLAMP NUT MOUNTING NUT LOCKWASHER | STAINLESS STEEL PER ASTM-A484 AND ASTM- A582, TYPE 303 | PASSIVATE PER ASTM-A380 |
| DIELECTRIC | TFE FLUOROCARBON PER ASTM-D-1457, MIL-P-19468, AND FED. SPEC L-P-403 | N/A |
| CENTER CONTACT BUSHING | BERYLLIUM COPPER PER QQ-C-530, ALLOY 173 | GOLD PLATE PER MIL-G-45204 OVER COPPER PLATE PER MIL-C-14550 |
| GASKET O-RING | SILICONE RUBBER PER ZZ-R-765 | N/A |

NOTES:

- DESIGNED FOR USE WITH
.250 DIA SEMI-RIGID CABLE.

| CABLE ENTRY DIAMETER MINIMUM | UNLESS OTHERWISE SPECIFIED DIMENSIONS ARE IN INCHES TOLERANCE ON | DRAWN BY L.ROSS | DATE 6-28-89 | AMP Incorporated 140 Fourth Avenue Waltham, MA 02451-7599 | | |
|---------------------------------|---|---------------------|-----------------|--|--|--|
| CONTACT | .065 | CHECKED BY C.W. | 6-28-89 | AMP TITLE OSN BULKHEAD FEEDTHROUGH CABLE JACK-COMPRESSION CLAMP ATTACHMENT SIZE B CODE IDENT NO. 26805 3004-7750-02 REV 01 ₀ SCALE 2:1 SHEET 1 OF 1 | | |
| | | APPD BY S.T.M. | 6-28-89 | | | |
| | These drawings and specifications are the property of Omni Spectra Incorporated and shall not be reproduced or copied or used in whole or in part as the basis for the manufacture or sale of item(s) without written permission. | USE ASS'Y PROCEDURE | | NO. AP. 408-04898 (30-024) | | |

CUSTOMER DRAWING

AMP PART # 1057151-1
SHEET 1 OF 1 REV A

单击下面可查看定价，库存，交付和生命周期等信息

[>>TE Connectivity\(泰科\)](#)