

© 1964 BY AMP INCORPORATED. ALL RIGHTS RESERVED. AMP PRODUCTS COVERED BY PATENTS AND/OR PATENTS PENDING. APPROVED PER GOVT CONTRACT NO.

LOCATION FOR AMP-TAB FEMALE CONTACT

LOCATION FOR KEYING PLUG 582501-1 (FOR INTER-CONTACT KEYING)

CIRCUIT CAVITY IDENTIFICATION PER MIL-C-21097B (582599-6 ONLY)

REVISIONS				
ZONE	LTR	DESCRIPTION	DATE	APPROVED
✓	AA	REVISED PER 0600-3683-95	TA	10-95 J. WARNER
	AB	ECO-08-020973	PY	11-08 JW
	AC	ECO-08-029243	PY	12-08 DE
	AD	ECO-10-023330	PY	2-11 DE

582599-6 AS SHOWN

OBSOLETE ~~582599-1~~ AS SHOWN "J" DIA. HOLES = .128

OBSOLETE ~~582599-2~~ SAME AS -1 EXCEPT "J" DIA. HOLES = .150

OBSOLETE ~~582599-3~~ REFER TO DWG. 582599-3

OBSOLETE 582599-4 1. SAME AS -2 EXCEPT; SPECIAL PART.
OBSOLETE ~~582599-5~~ 1. SAME AS -1 EXCEPT; MOLDED THREADED INSERT.

- ▲ GROOVES FOR "ON CONTACT KEYING" AMP'S OPTION DEPENDING ON METHOD OF MANUFACTURE; FOR "ON CONTACT" KEYING USE KEYING PLUG P/N 583487-1. (MUST BE ORDERED SEPARATELY.)
- ▲ MOUNTING EAR CONFIGURATION AMP'S OPTION DEPENDS ON METHOD OF MANUFACTURE.
- 3. LASER MARKING ACCEPTABLE FOR ALL MARKING

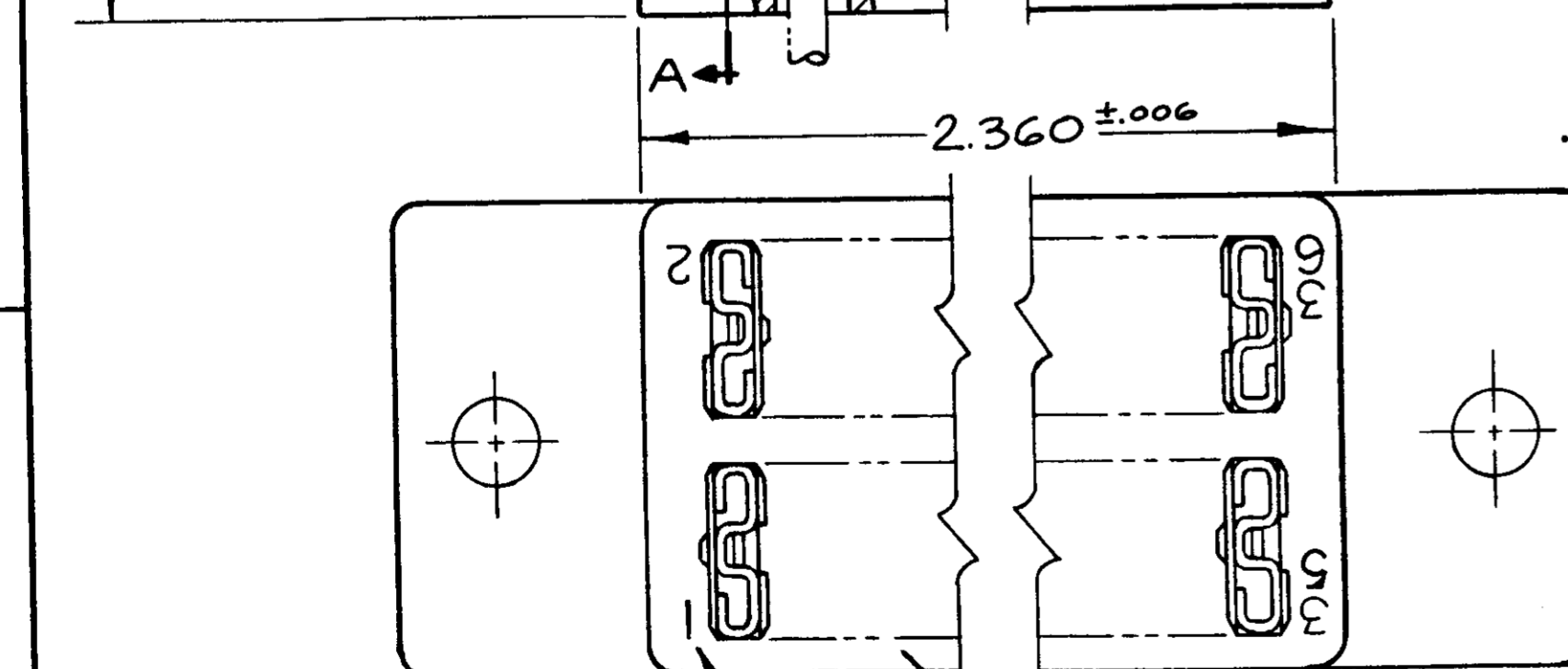
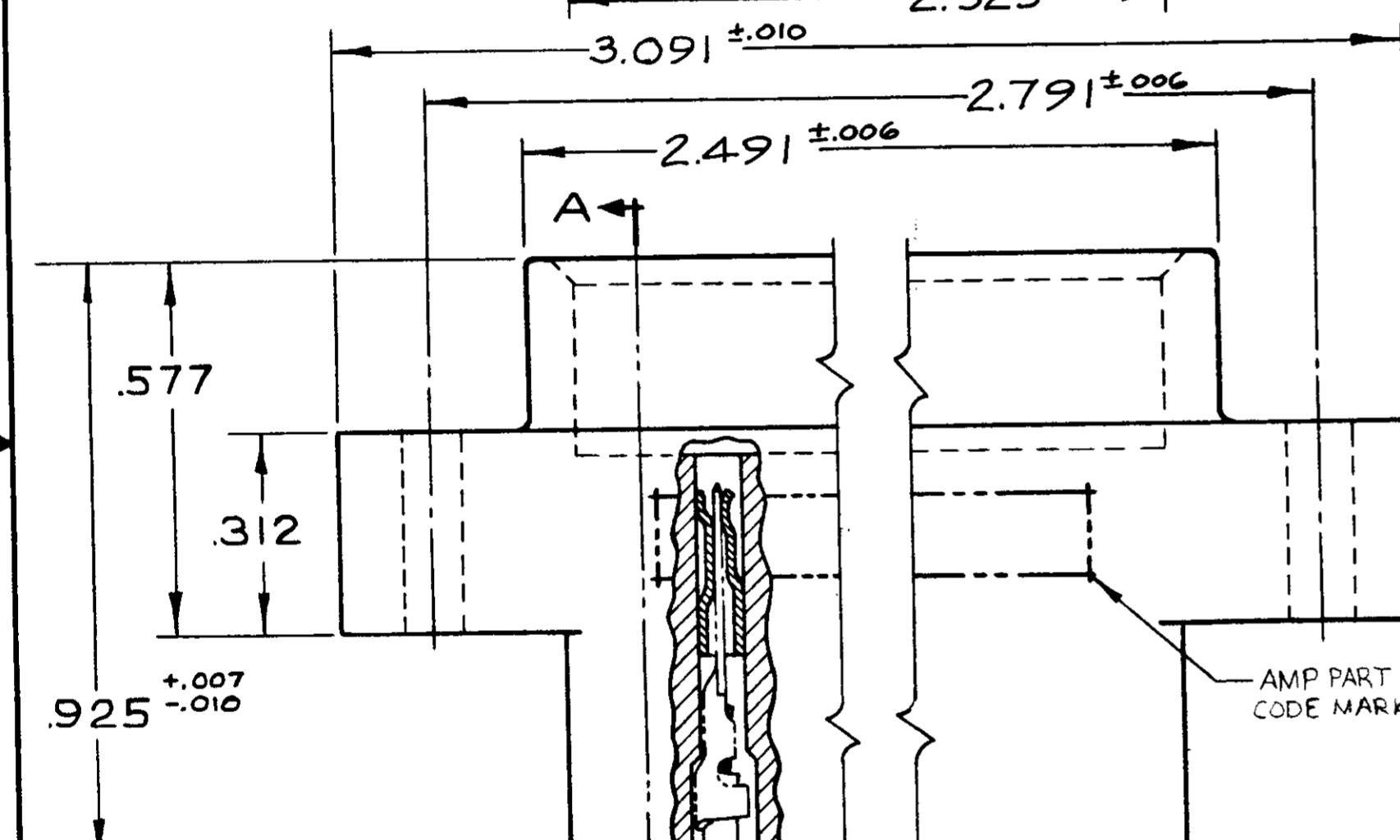
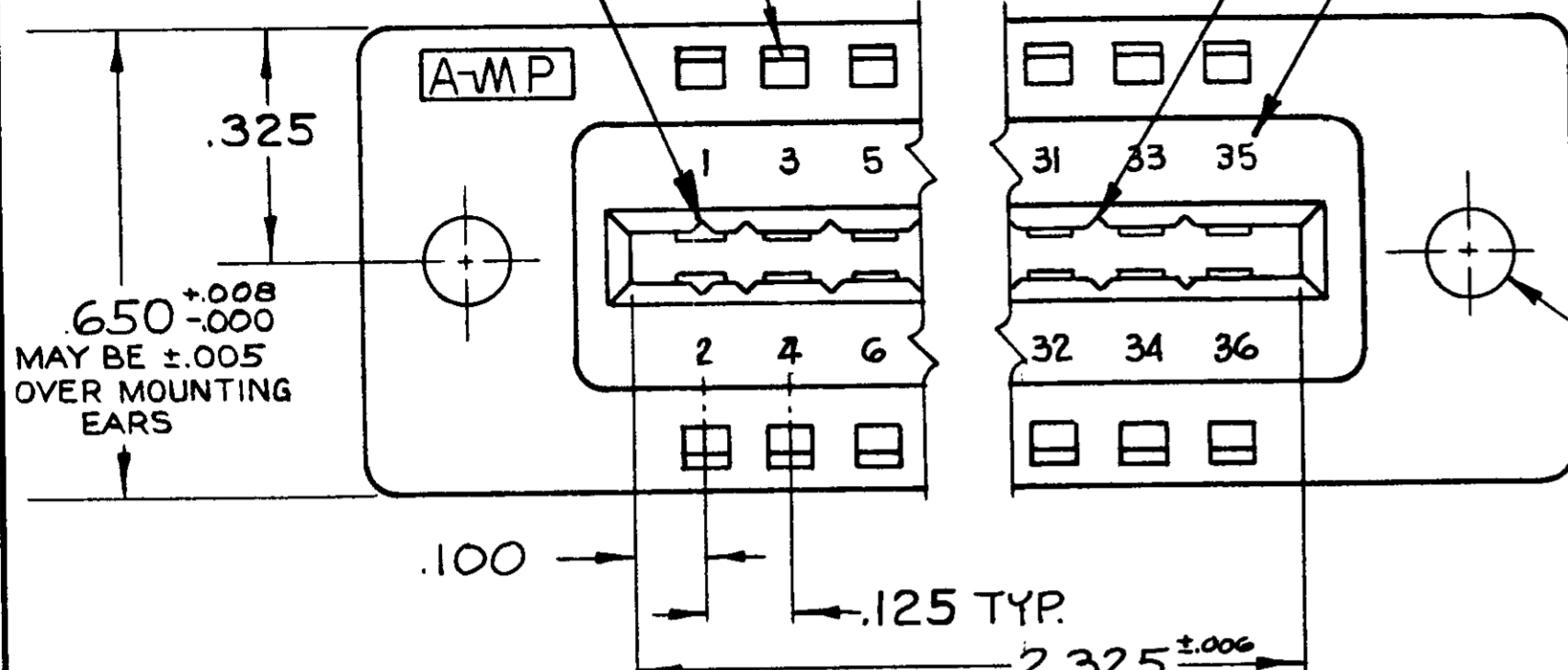

CIRCUIT CAVITY IDENTIFICATION MARKING PER MIL-C-21097B

MARK FIRST 5 POSITIONS, NEXT 5 POSITIONS PLAIN

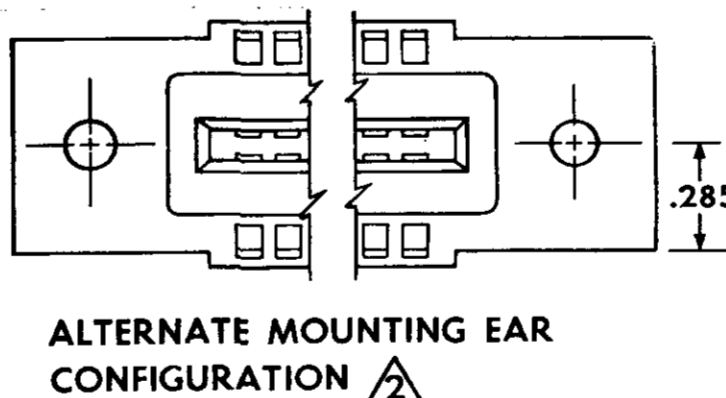
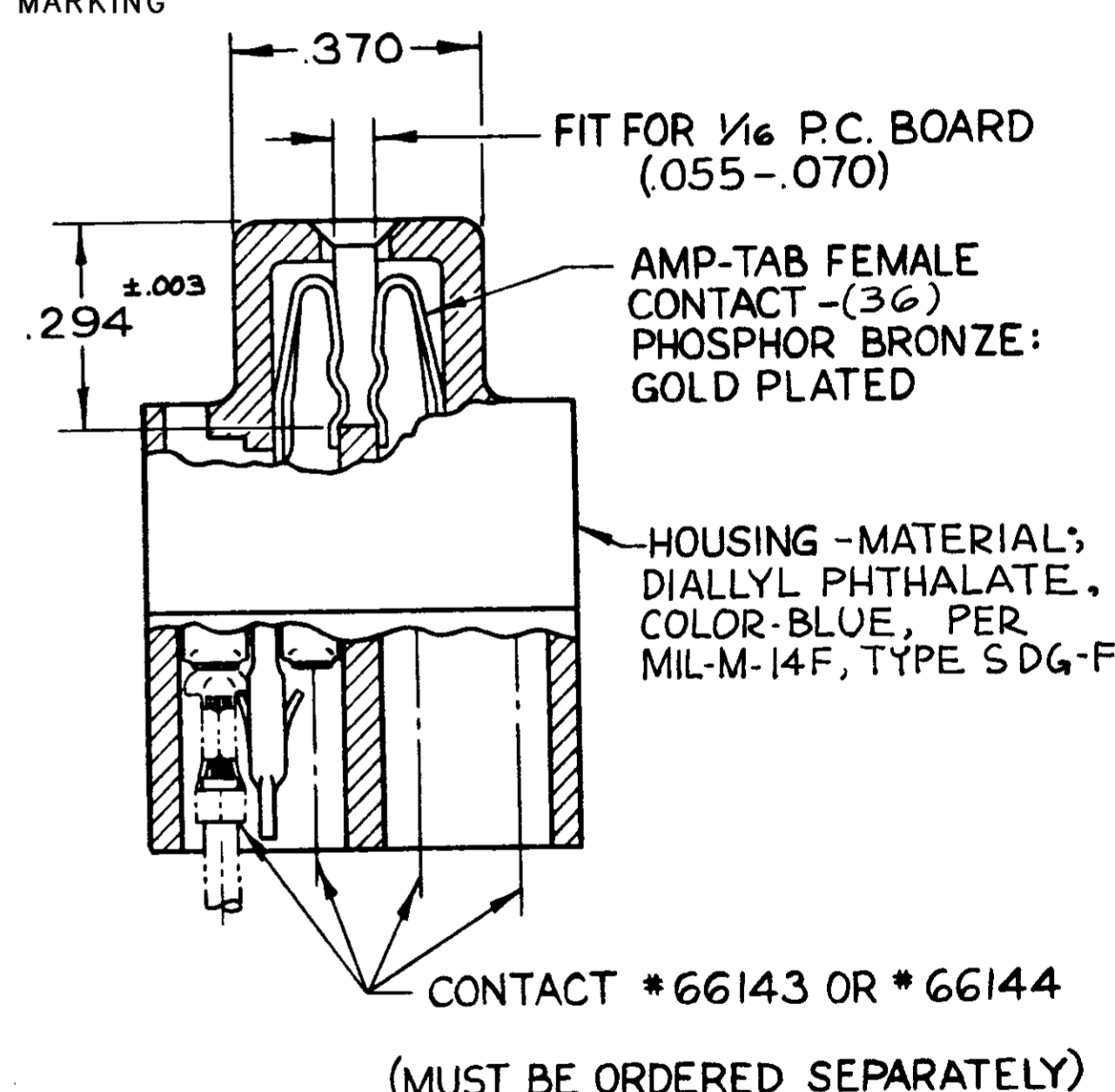
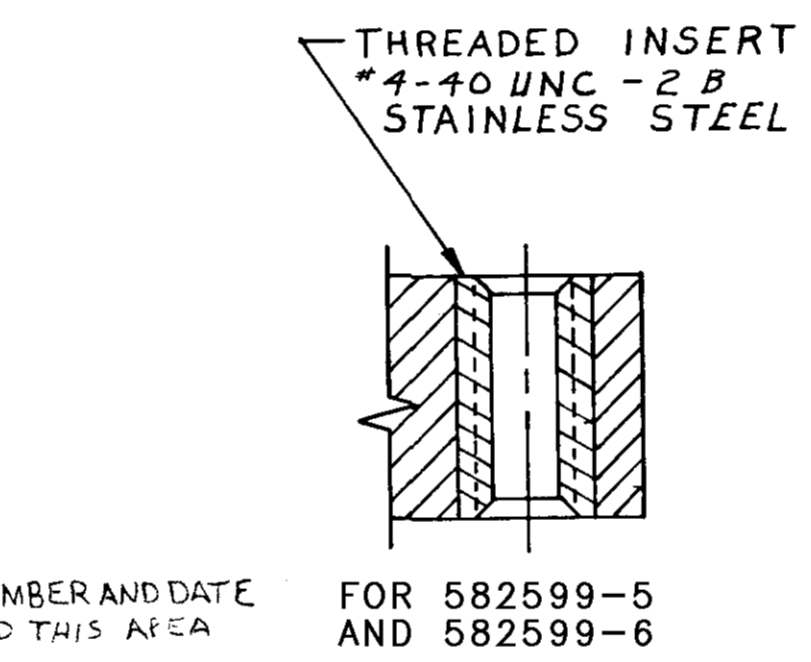

UNLESS OTHERWISE SPECIFIED		CONTRACT NO.	
DIMENSIONS ARE IN INCHES		DR	DATE
FRACTIONS	TOLERANCES ON	J. Asch	4-27-67
DECIMALS	ANGLES	CHK	DATE
± .005	±	S. Herda	7/2/67
MATERIAL		DSGN ENGR	DATE
SEE CALLOUT		APPD	DATE
HEAT TREAT		DSGN APPD	DATE
FINISH		OTHER APPD	
SEE CALLOUT			

AMP INCORPORATED HARRISBURG, PENNSYLVANIA			
NAME: 18 POSITION AMP-TAB CONNECTOR .125 CENTERS QUAD			
SIZE: C	CODE IDENT NO: 00779	NUMBER: 582599	REV: AD
SCALE: 4 -	WT	CALC	ACTUAL
SHEET			

CUSTOMER DRAWING

AMP INFO
LOC PRINT
DF FO

NUMBER CUS. 582599

单击下面可查看定价，库存，交付和生命周期等信息

[>>TE Connectivity\(泰科\)](#)