

THIS DRAWING IS UNPUBLISHED.

RELEASED FOR PUBLICATION

© COPYRIGHT - By -

ALL RIGHTS RESERVED.

LOC GP DIST 00

REVISIONS

P	LTR	DESCRIPTION	DATE	DWN	APVD
	C	REV PER ECO-11-007264	14APR2011	RG	DO

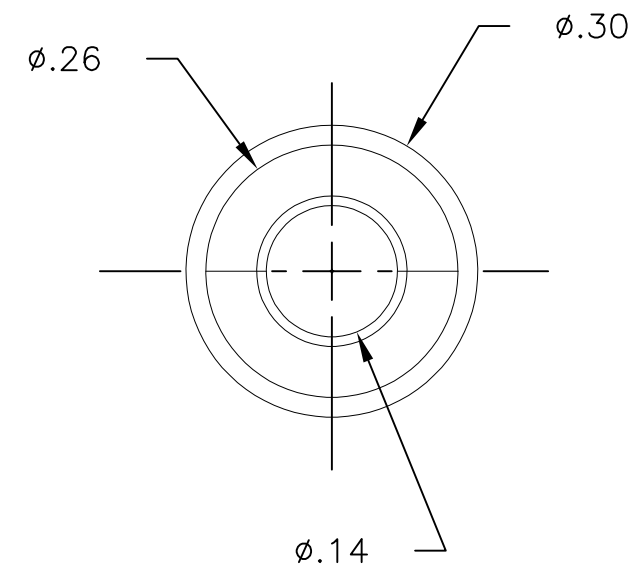
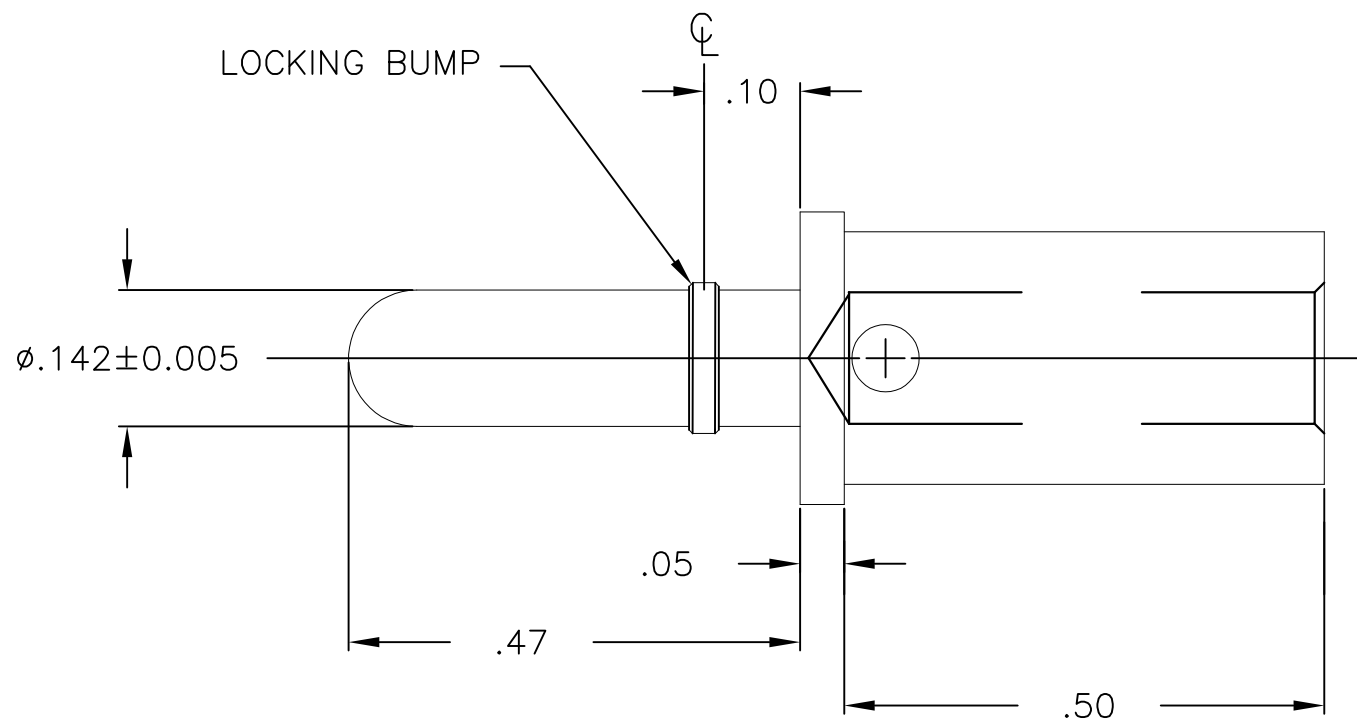

- 5. TOOLING REQUIRED FOR CRIMP CONTACTS SIZE #8 & #10:
 CRIMP TOOL PART No. M22520/23-01
 CRIMP DIE ASSEMBLY PART No. M22520/23-02
 LOCATOR PART No. M22520/23-09

4. FINISH: SILVER PLATE .00200 MIN THK. OVER
 NICKEL .000040 MIN THK.

3. MATERIAL: COPPER ALLOY

2. ITEMS PROVIDED TO THIS SPECIFICATION TO BE IDENTIFIED
 ON THE CONTAINER WITH THE FOLLOWING INFORMATION:
 PART NUMBER AND DATE CODE OF MANUFACTURE.

1. PART NUMBER CHANGES AND/OR DESIGN CHANGES AFFECTING
 ITEM INTERCHANGEABILITY REQUIRE PRIOR ELCON APPROVAL
 AND AUTHORIZATION BY REVISION TO THIS DRAWING.

1766161-1
 PART NUMBER

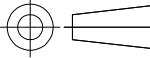
THIS DRAWING IS A CONTROLLED DOCUMENT.		DWN 10JAN2011 LOVATO/GRZYBOWSKI	 TE Connectivity		
DIMENSIONS: INCHES		CHK 10JAN2011 D.ORRIS			
		APVD 10JAN2011 D.ORRIS	PIN CONTACT SIZE No.8 SIZE No.10 CRIMP BARREL LOCKING ICCON		
TOLERANCES UNLESS OTHERWISE SPECIFIED:		PRODUCT SPEC	RESTRICTED TO		
0 PLC ± - 1 PLC ± - 2 PLC ± - 3 PLC ± .020 4 PLC ± - ANGLES ± .5		APPLICATION SPEC	SIZE	CAGE CODE	DRAWING NO
MATERIAL		WEIGHT	A3	00779	C-1766161
FINISH		CUSTOMER DRAWING		SCALE 5:1	SHEET 1 OF 1
				REV C	

单击下面可查看定价，库存，交付和生命周期等信息

[>>TE Connectivity\(泰科\)](#)