

- ① MATERIAL: STAINLESS STEEL.
- ② MATERIAL: BRASS.
- ③ FINISH: PASSIVATE.
- ④ FINISH: 0.00038-0.00102 [.000150-.000400] NICKEL PLATE.
- ⑤ PART NUMBER IS OBSOLETE.

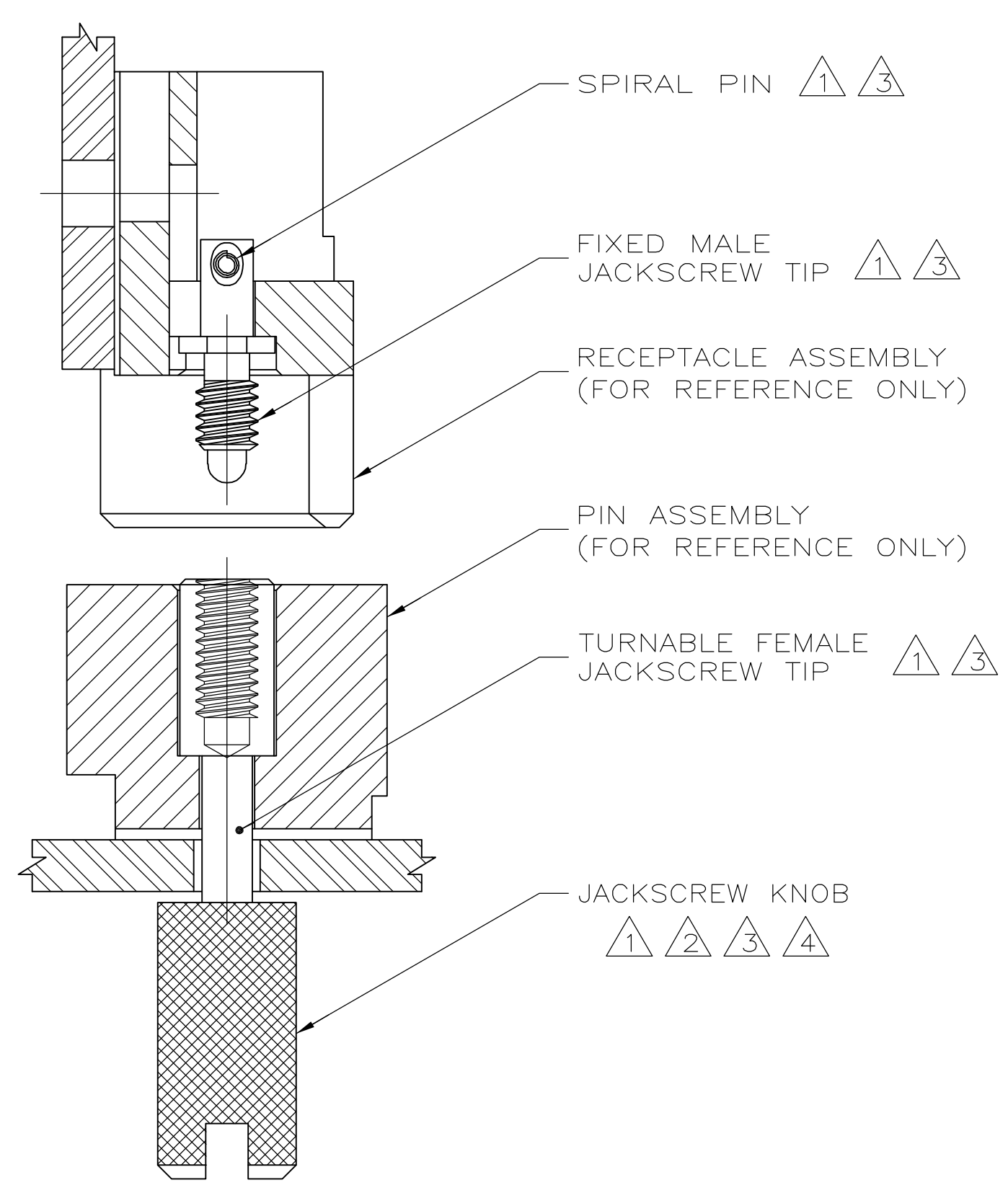
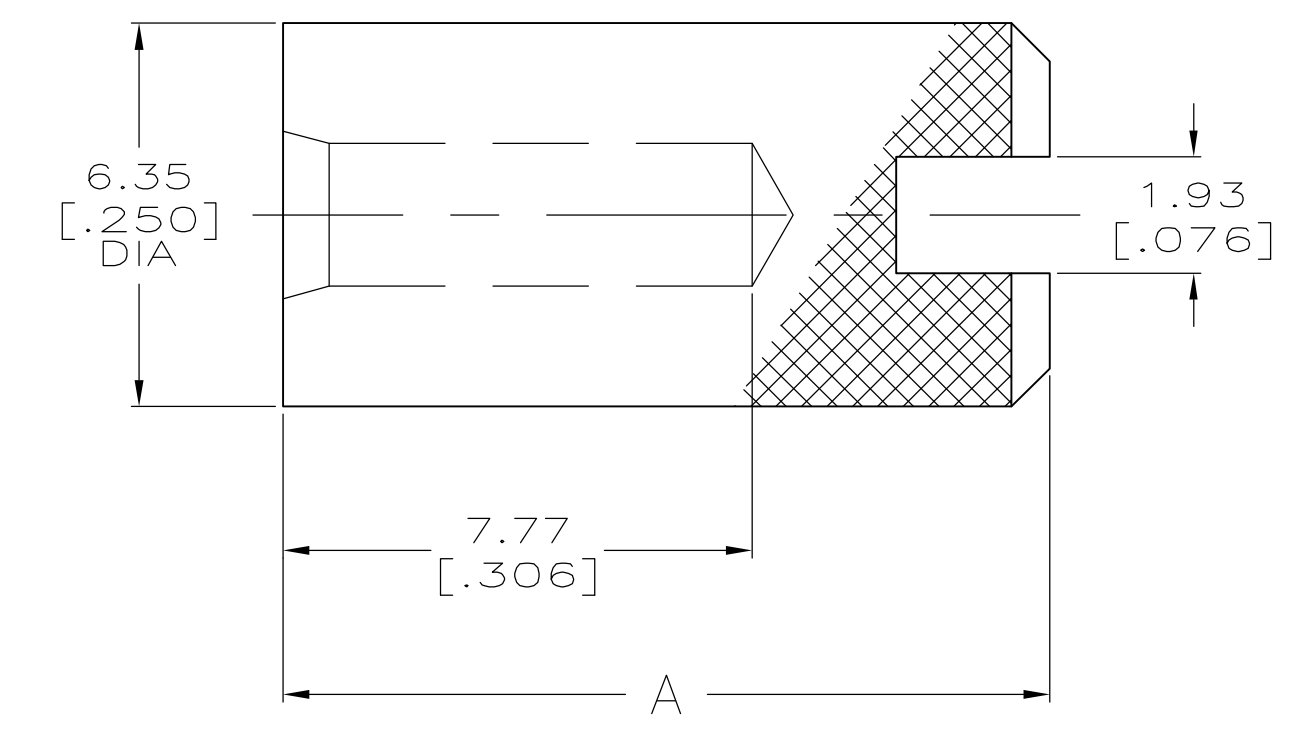
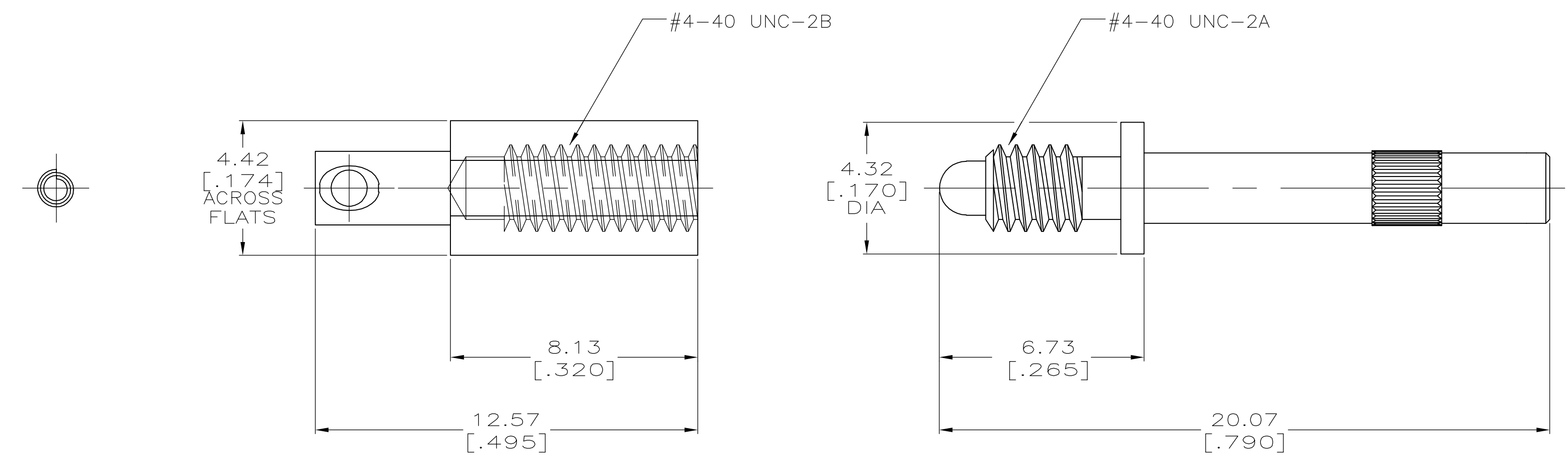

⑤	—	—	—	—	532805-8
⑤	—	—	—	—	532805-7
⑤	—	—	—	—	532805-6
⑤	—	—	—	—	532805-5
⑤	YES	③	①	3.18 [1.250]	532805-4
⑤	YES	③	①	1.27 [.500]	532805-3
⑤	NO	③	①	1.27 [.500]	532805-2
⑤	—	③	①	—	532805-1
	SLOT FOR SCREWDRIVER	FINISH	MATERIAL	A	PART NUMBER

THIS DRAWING IS A CONTROLLED DOCUMENT.		DWN R.K. SEIFRIED 1-31-94	Tyco Electronics Corporation Harrisburg, PA 17105-3608																												
DIMENSIONS: mm [INCHES]		TOLERANCES UNLESS OTHERWISE SPECIFIED:		APVD G. SKIPPER																											
<table border="1"> <tr><td>0</td><td>PLC</td><td>±</td><td>—</td></tr> <tr><td>1</td><td>PLC</td><td>±</td><td>—</td></tr> <tr><td>2</td><td>PLC</td><td>±</td><td>—</td></tr> <tr><td>3</td><td>PLC</td><td>±</td><td>.005</td></tr> <tr><td>4</td><td>PLC</td><td>±</td><td>—</td></tr> <tr><td colspan="2">ANGLES</td><td>±</td><td>—</td></tr> <tr><td colspan="2">FINISH</td><td>±</td><td>—</td></tr> </table>		0	PLC	±	—	1	PLC	±	—	2	PLC	±	—	3	PLC	±	.005	4	PLC	±	—	ANGLES		±	—	FINISH		±	—	NAME HDI, JACKSCREW KIT, FIXED FEMALE, TURNABLE MALE	
0	PLC	±	—																												
1	PLC	±	—																												
2	PLC	±	—																												
3	PLC	±	.005																												
4	PLC	±	—																												
ANGLES		±	—																												
FINISH		±	—																												
MATERIAL ① ②		FINISH ③ ④		SIZE A1																											
CUSTOMER DRAWING		SCALE 8:1		SHEET 1 OF 1 REV J																											

单击下面可查看定价，库存，交付和生命周期等信息

[>>TE Connectivity\(泰科\)](#)