

| LOC | DIST | P | F | ZONE | LTR | DESCRIPTION | DATE | APPD |
|-----|------|---|---|------|-----|---------------------------|---------|------|
| G | 14 | | | | | REVISED PER ECR 06-014478 | 14JUN06 | JR |

METRIC
 DIMENSIONS LISTED IN mm [INCHES]

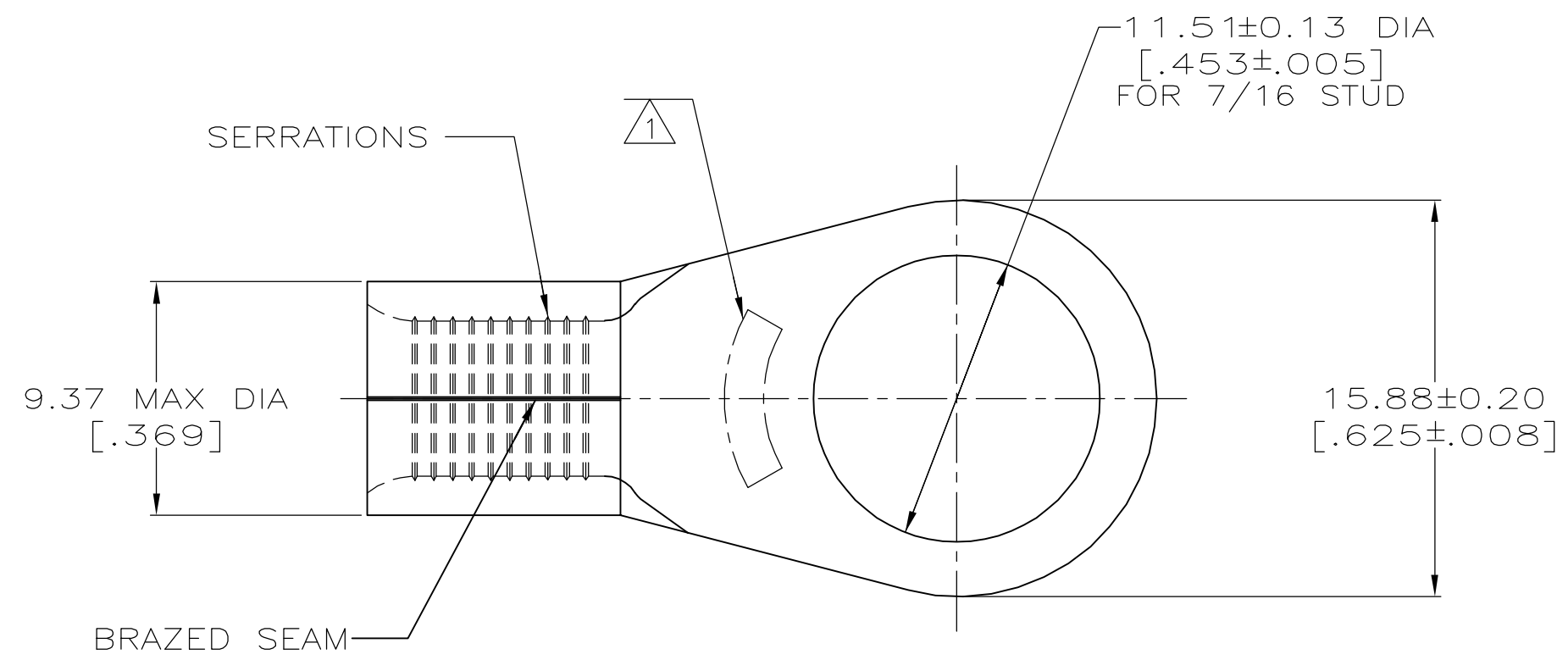

| | |
|----------------------------|---------------------------|
| AMP WIRE RANGE | Listed |
| 6 AWG SOLID OR STRANDED | 6 AWG STRANDED |
| LR7189 Certified | MILITARY P/N AND CLASS |
| 6 AWG SOLID OR STRANDED | NOT APPLICABLE |

STAMP AMP 6* APPROX AS SHOWN

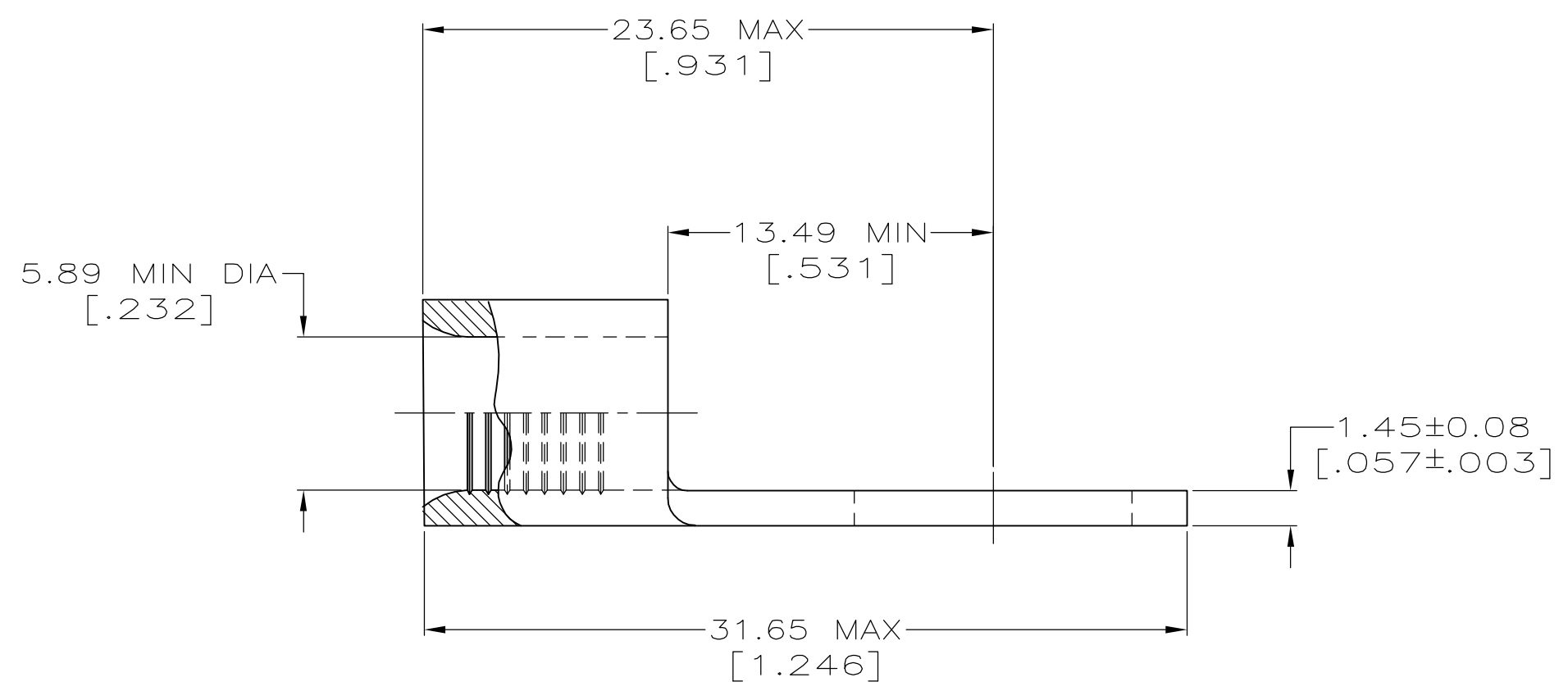

320745
 PART NO

**AMP INCORPORATED
 CUSTOMER SERVICE SYSTEMS**

MAX RECOMMENDED OPERATING TEMPERATURE:
 170° C MAX

DO NOT SCALE PRINT. UNLESS SPECIFIED
 DIMENSIONS IN mm [INCHES]—
 TOLERANCES ON :
 2 PLC DEC ± -
 3 PLC DEC ± -
 ANGLES ± -

DR 3-24-93
 TA BRINKMAN
 CHK 3-24-93
 DA PATTERSON

AMP AMP Incorporated
 Harrisburg, PA 17105-3608

FOR ADDITIONAL PRODUCT INFORMATION OR COPIES OF DRAWINGS AND TECHNICAL DOCUMENTS

PRODUCT INFORMATION CENTER
 1-800-522-6752

VOLTAGE RATING:
 NOT APPLICABLE

MATERIAL
 COPPER PER ASTM B-152 ANNEALED

APPD 3-24-93
 DE MILLER
 APPD 3-24-93
 JL MECKLEY
 PRODUCT SPEC -

NAME
TERMINAL, RING TONGUE, SOLISTRAND™?

FOR APPLICATION TOOLING INFORMATION

TOOLING ASSISTANCE CENTER
 1-800-722-1111

WIRE CROSS SECTIONAL AREA RANGE:
 10.5-16.8MM² [20,800-33,100] CIR MILS
 SOLID OR STRANDED

FINISH
 TIN PLATE 0.00254 [.000100] MIN THK PER MIL-T-10727

APPLICATION SPEC -
 WEIGHT -

SIZE CAGE CODE 00779 DRAWING NO 320745
 SCALE 4:1 SHEET 10F 1

THIS DRAWING IS A CONTROLLED DOCUMENT FOR AMP INCORPORATED. IT IS SUBJECT TO CHANGE AND THE CONTROLLING ENGINEERING ORGANIZATION SHOULD BE CONTACTED FOR THE LATEST REVISION.

单击下面可查看定价，库存，交付和生命周期等信息

[>>TE Connectivity\(泰科\)](#)