

THIS DRAWING IS UNPUBLISHED. RELEASED FOR PUBLICATION 20
 © COPYRIGHT 20 BY - ALL RIGHTS RESERVED.

LOC	DIST	REVISIONS					
GP	00	P	LTR	DESCRIPTION	DATE	DWN	APVD
		A		RELEASE	31OCT2016	JY	SH

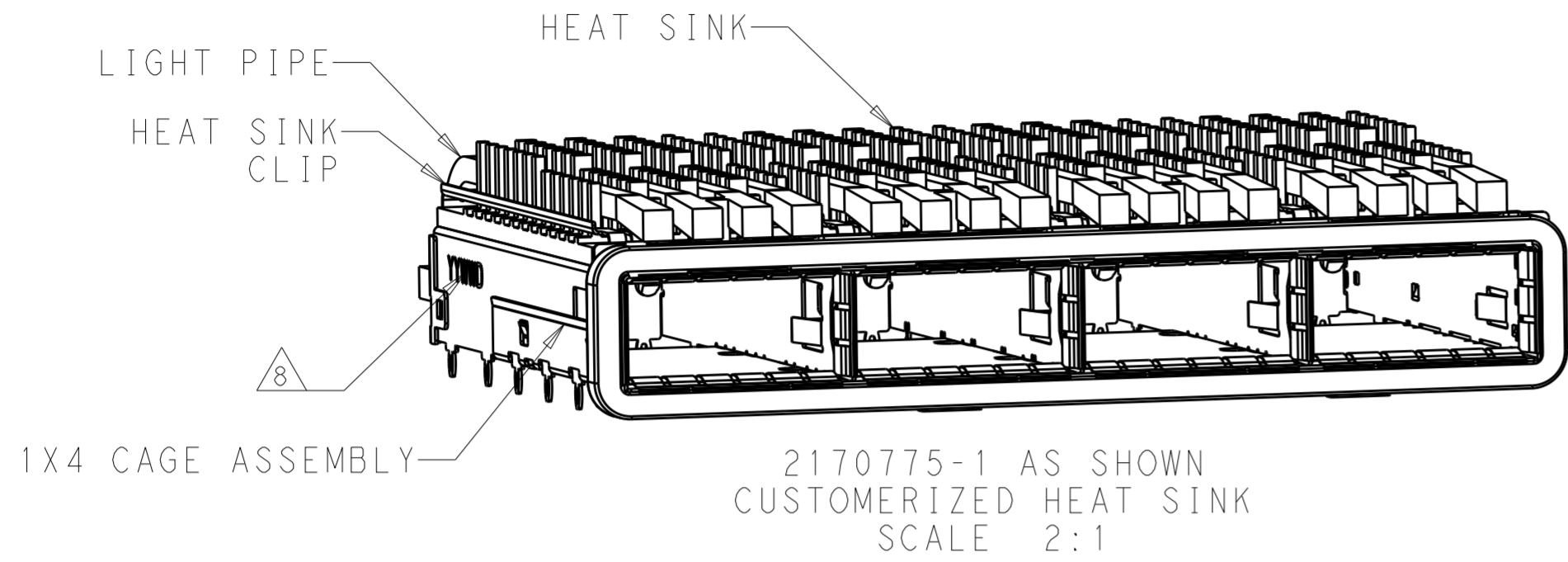

- COMPONENTS
 CAGE ASSEMBLY: NICKEL-SILVER ALLOY
 HEAT SINK: ALUMINUM/BLACK ANODIZE
 HEAT SINK CLIP: STAINLESS STEEL
 EMI SPRING: COPPER ALLOY/NICKEL PLATE
 GASKET: PLATED FILLED SILICONE
 LIGHT PIPE: CLEAR POLYCARBONATE WITH UL 94 V_0
 ORGANIZER: POLYESTER WITH UL 94 V_0
- REFERENCE APPLICATION SPECIFICATION 114-32023 FOR RECOMMENDED DRILL HOLE DIAMETER AND PLATING THICKNESS
- DATUM AND BASIC DIMENSION ESTABLISHED BY CUSTOMER
- DIMENSION APPLIES WITH MODULE INSERTED IN CAGE
- HEAT SINKS, HEAT SINK CLIPS AND LIGHT PIPES ARE SHIPPED ASSEMBLED ON CAGE
- MINIMUM PC BOARD THICKNESS: SINGLE SIDED: 1.57 MIN
DOUBLE SIDED: 3.00 MIN
- MATES WITH QSFP28 MSA COMPATIBLE TRANSCEIVER.
- DATE CODE (YYWWD) MARKED APPROXIMATELY AS SHOWN.

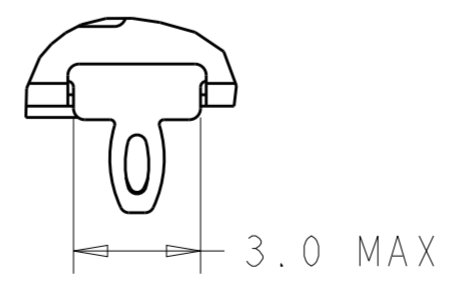
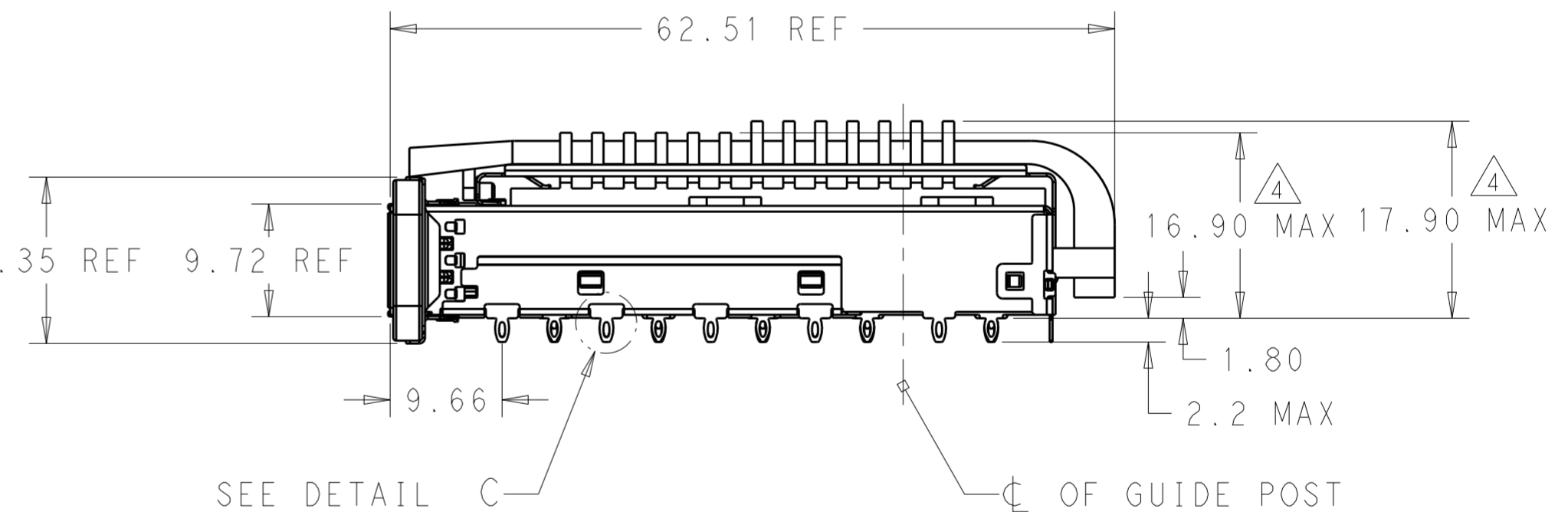
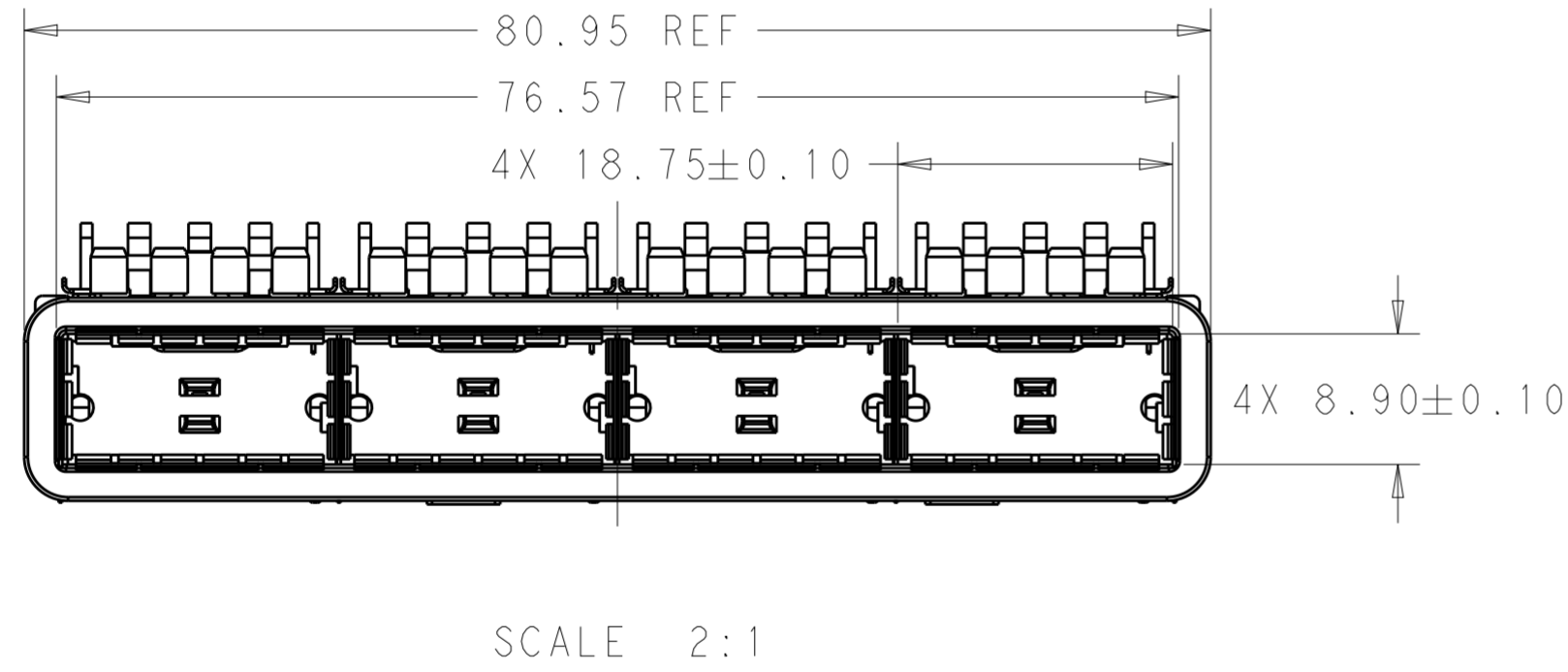

CUSTOMERIZED	2170775-4
CUSTOMERIZED	2170775-3
CUSTOMERIZED	2170775-2
CUSTOMERIZED	2170775-1
HEAT SINK HEIGHT	PART NUMBER

THIS DRAWING IS A CONTROLLED DOCUMENT.		DWN	20AUG2014	STE		TE Connectivity	
DIMENSIONS: mm		CHK	JASON YANG	NAME		CAGE ASSEMBLY, QSFP28, 1X4 WITH HEAT SINKS AND LIGHT PIPES, THRU BEZEL, GASKET	
TOLERANCES UNLESS OTHERWISE SPECIFIED:		APVD	SEAN HAN	SIZE		CAGE CODE	DRAWING NO
0 PLC	±	PRODUCT SPEC		A2	00779	C-2170775	RESTRICTED TO
1 PLC	±0.25	APPLICATION SPEC		SCALE	3:1	SHEET	1 OF 7
2 PLC	±0.2	WEIGHT				REV	A
3 PLC	±	CUSTOMER DRAWING					
4 PLC	±						
ANGLES	±						
FINISH	±						
SEE NOTES	SEE NOTES						

THIS DRAWING IS UNPUBLISHED. RELEASED FOR PUBLICATION 20
 © COPYRIGHT 20 BY - ALL RIGHTS RESERVED.

LOC		DIST		REVISIONS			
P	LTR	DESCRIPTION	DATE	DWN	APVD		
-		SEE SHEET 1	-	-	-		

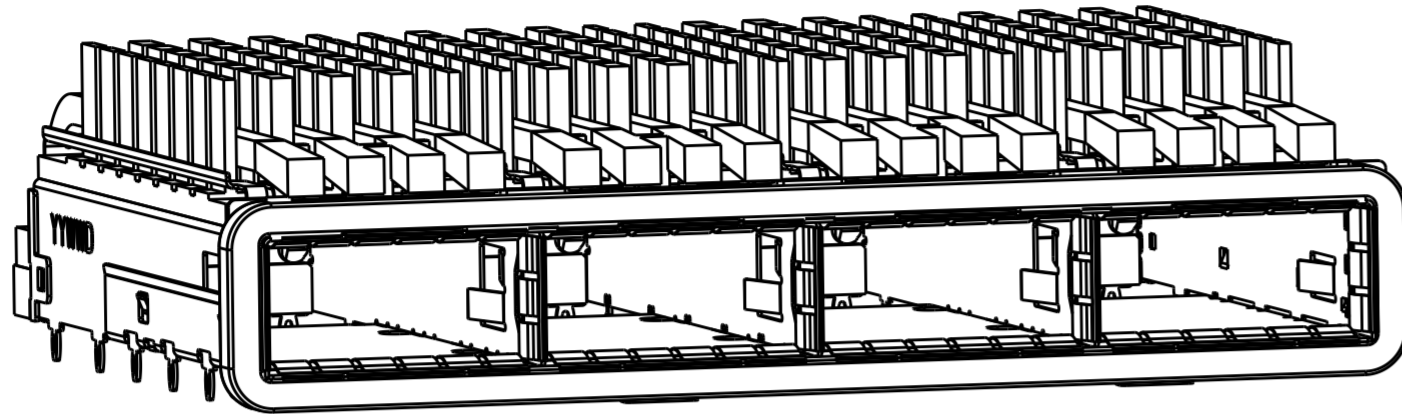

2170775-2 AS SHOWN
 CUSTOMERIZED HEAT SINK
 SCALE 2:1

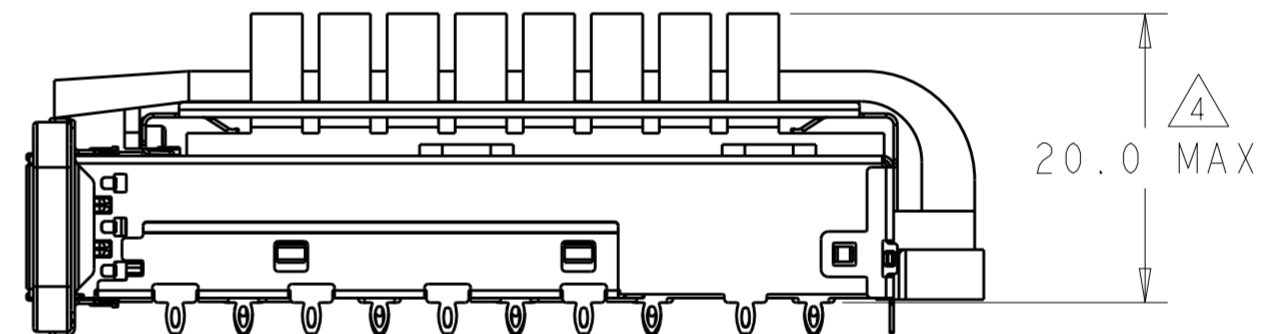
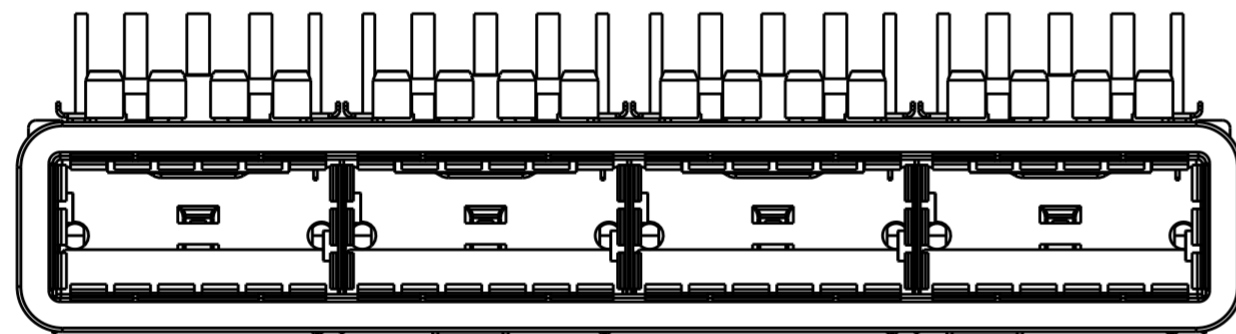

2170775-2
 UNSPECIFIED DIMENSIONS ARE SAME AS 2170775-1
 SCALE 2:1

THIS DRAWING IS A CONTROLLED DOCUMENT.		DWN JASON YANG 20AUG2014	 TE Connectivity	
		CHK SEAN HAN 31OCT2016		
DIMENSIONS:	TOLERANCES UNLESS OTHERWISE SPECIFIED:	APVD -	NAME CAGE ASSEMBLY, QSFP28, 1X4 WITH HEAT SINKS AND LIGHT PIPES, THRU BEZEL, GASKET	
mm	0 PLC ± 1 PLC ±0.25 2 PLC ±0.2 3 PLC ± 4 PLC ±	PRODUCT SPEC -	SIZE A200779	
	ANGLES ±	APPLICATION SPEC -	CAGE CODE C-2170775	DRAWING NO C-2170775
MATERIAL SEE NOTES material_2	FINISH SEE NOTES finish_spec_2	WEIGHT -	RESTRICTED TO -	
CUSTOMER DRAWING		SCALE 3:1	SHEET 2 OF 7	REV A

THIS DRAWING IS UNPUBLISHED. RELEASED FOR PUBLICATION 20
 © COPYRIGHT 20 BY - ALL RIGHTS RESERVED.

LOC		DIST		REVISIONS			
P	LTR	DESCRIPTION	DATE	DWN	APVD		
-		SEE SHEET 1	-	-	-		

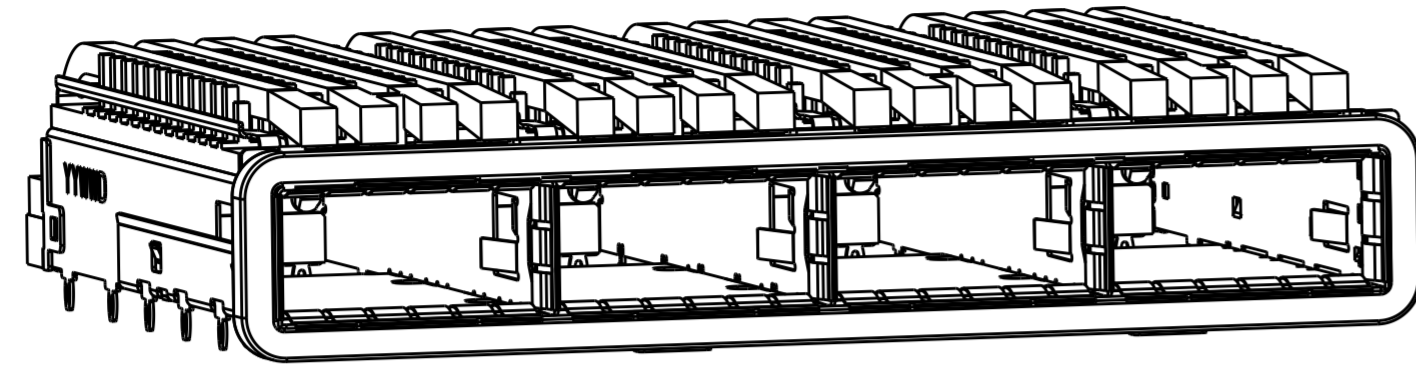

2170775-3 AS SHOWN
 CUSTOMERIZED HEAT SINK
 SCALE 2:1

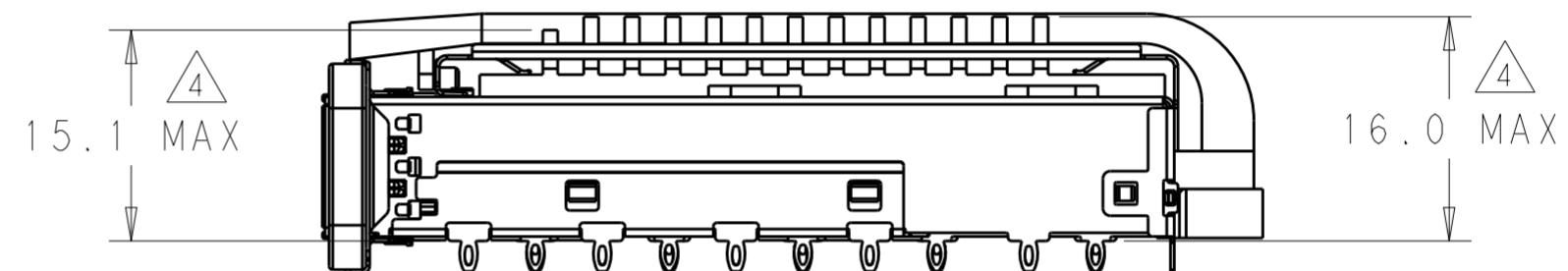
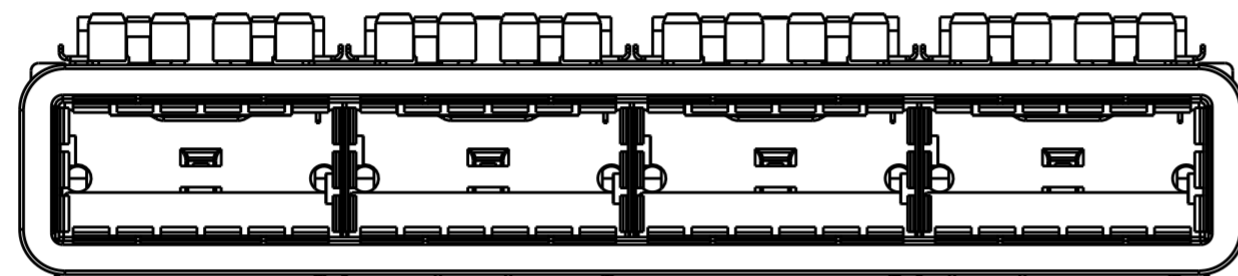

2170775-3
 UNSPECIFIED DIMENSIONS ARE SAME AS 2170775-1
 SCALE 2:1

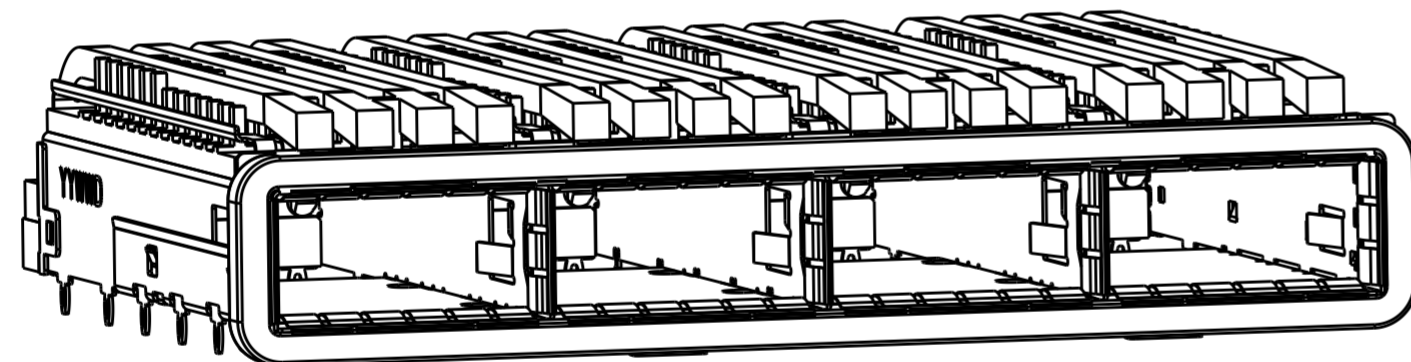

2170775-4 AS SHOWN
 CUSTOMERIZED HEAT SINK
 SCALE 2:1

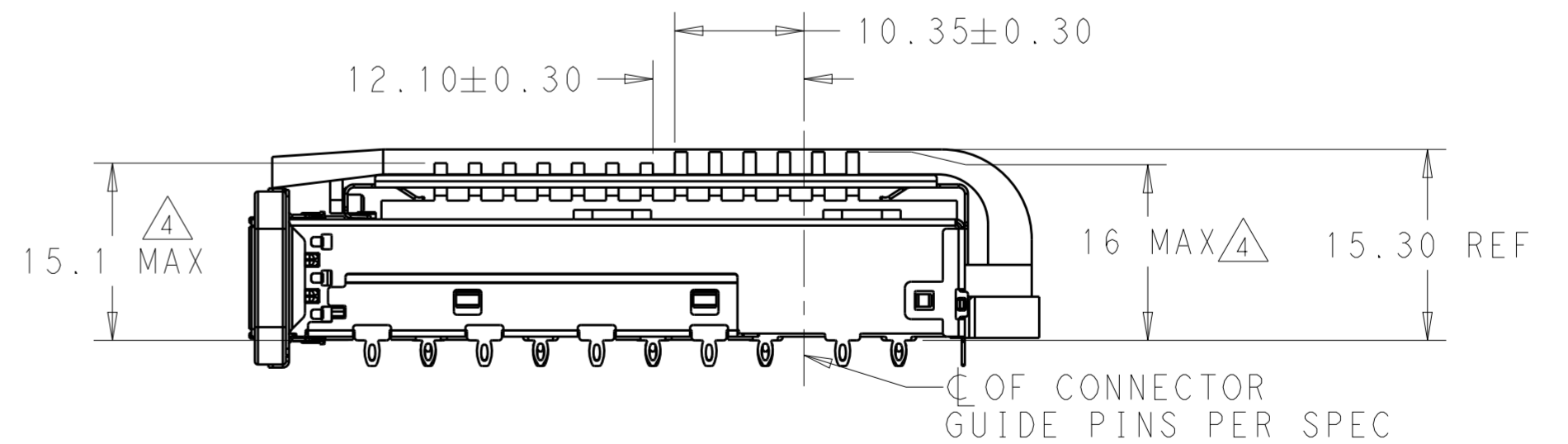
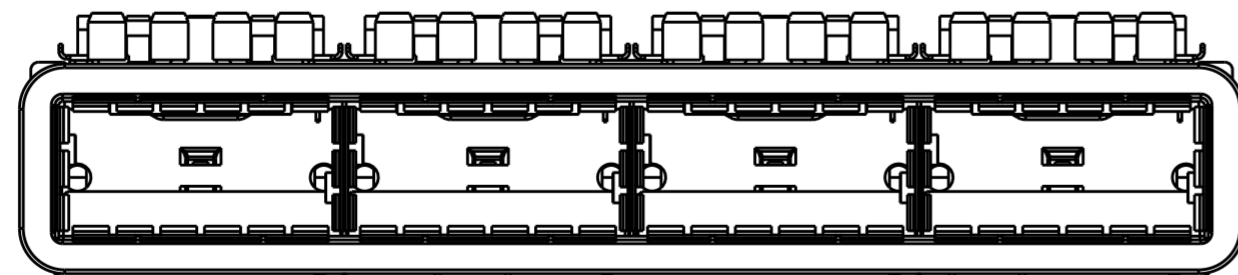

2170775-4
 UNSPECIFIED DIMENSIONS ARE SAME AS 2170775-3
 SCALE 2:1

THIS DRAWING IS A CONTROLLED DOCUMENT.		DWN JASON YANG 20AUG2014	TE Connectivity	
		CHK SEAN HAN 31OCT2016		
DIMENSIONS: mm		TOLERANCES UNLESS OTHERWISE SPECIFIED:		NAME CAGE ASSEMBLY, QSFP28, 1X4 WITH HEAT SINKS AND LIGHT PIPES, THRU BEZEL, GASKET
		0 PLC ± 1 PLC ±0.25 2 PLC ±0.2 3 PLC ± 4 PLC ± ANGLES ± FINISH		SIZE A200779
MATERIAL SEE NOTES material_2		FINISH SEE NOTES finish_spec_2		DRAWING NO C-2170775
		WEIGHT -		RESTRICTED TO -
		CUSTOMER DRAWING		SCALE 3:1 SHEET 3 OF 7 REV A

THIS DRAWING IS UNPUBLISHED. RELEASED FOR PUBLICATION 20
 © COPYRIGHT 20 BY - ALL RIGHTS RESERVED.

LOC		DIST		REVISIONS			
P	LTR	DESCRIPTION	DATE	DWN	APVD		
-	-	SEE SHEET 1	-	-	-		

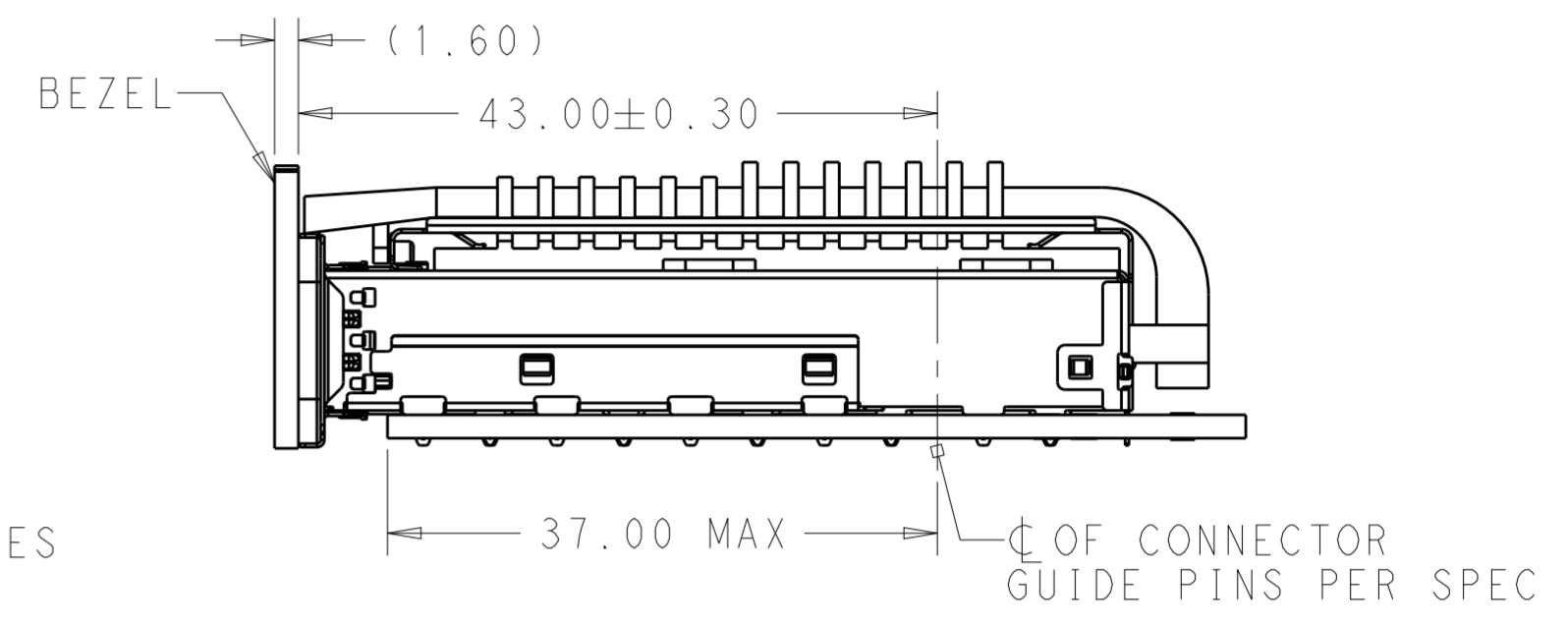
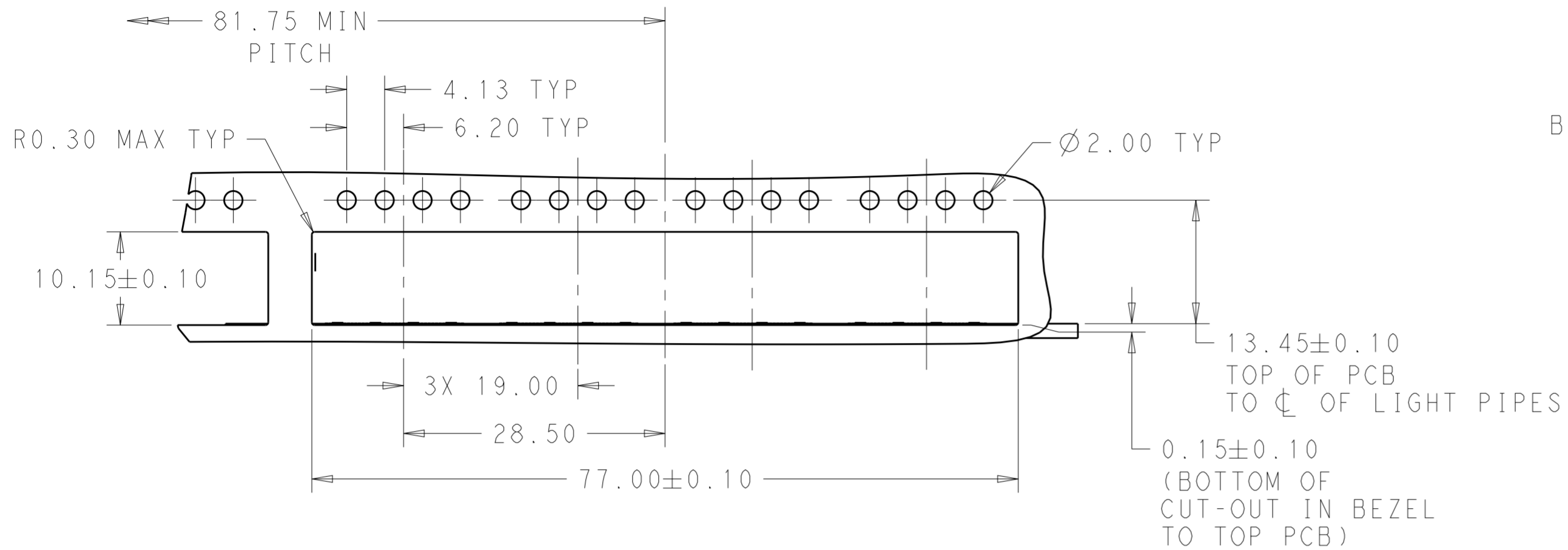

SINGLE SIDE MOUNTING
SCALE 2:1

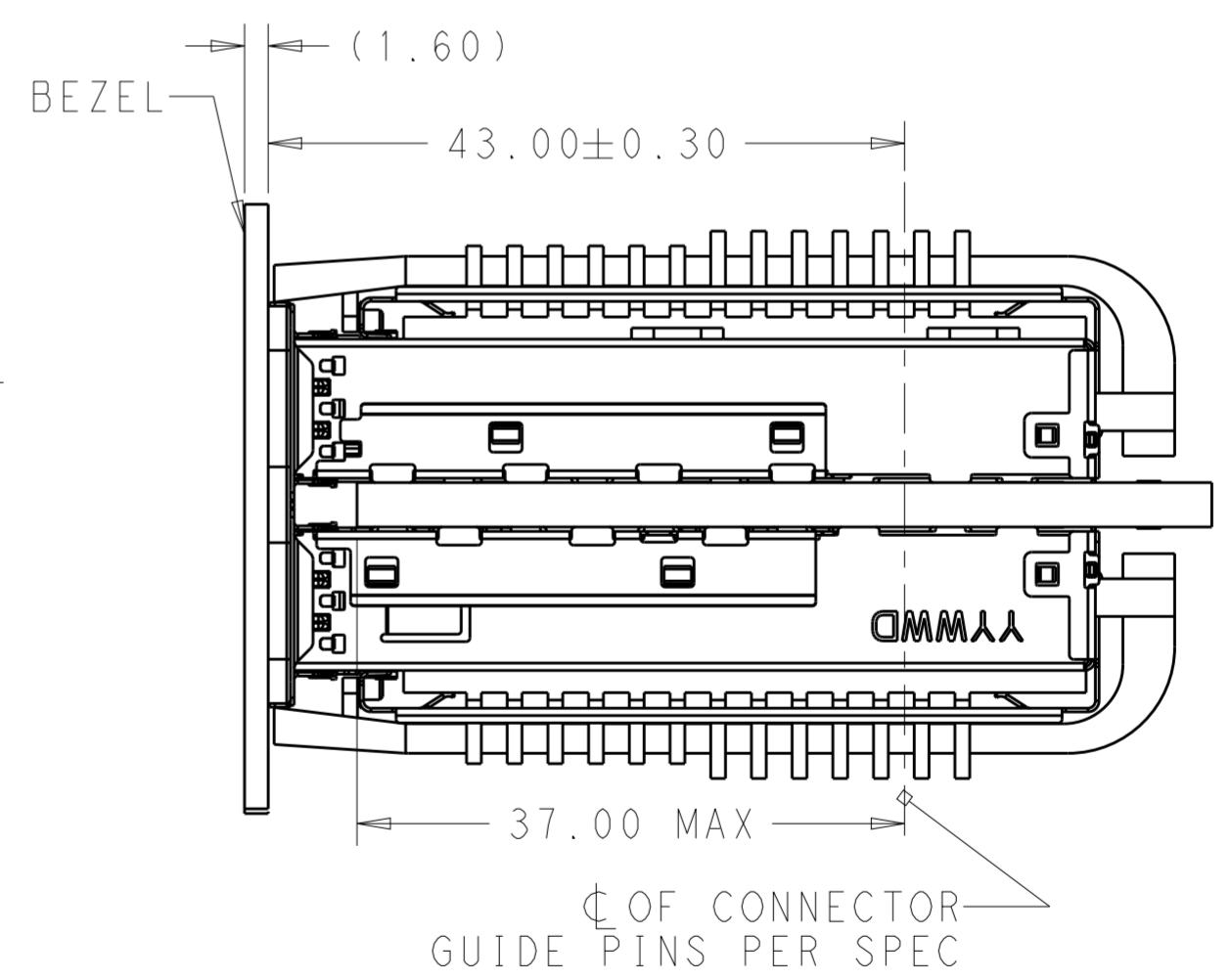
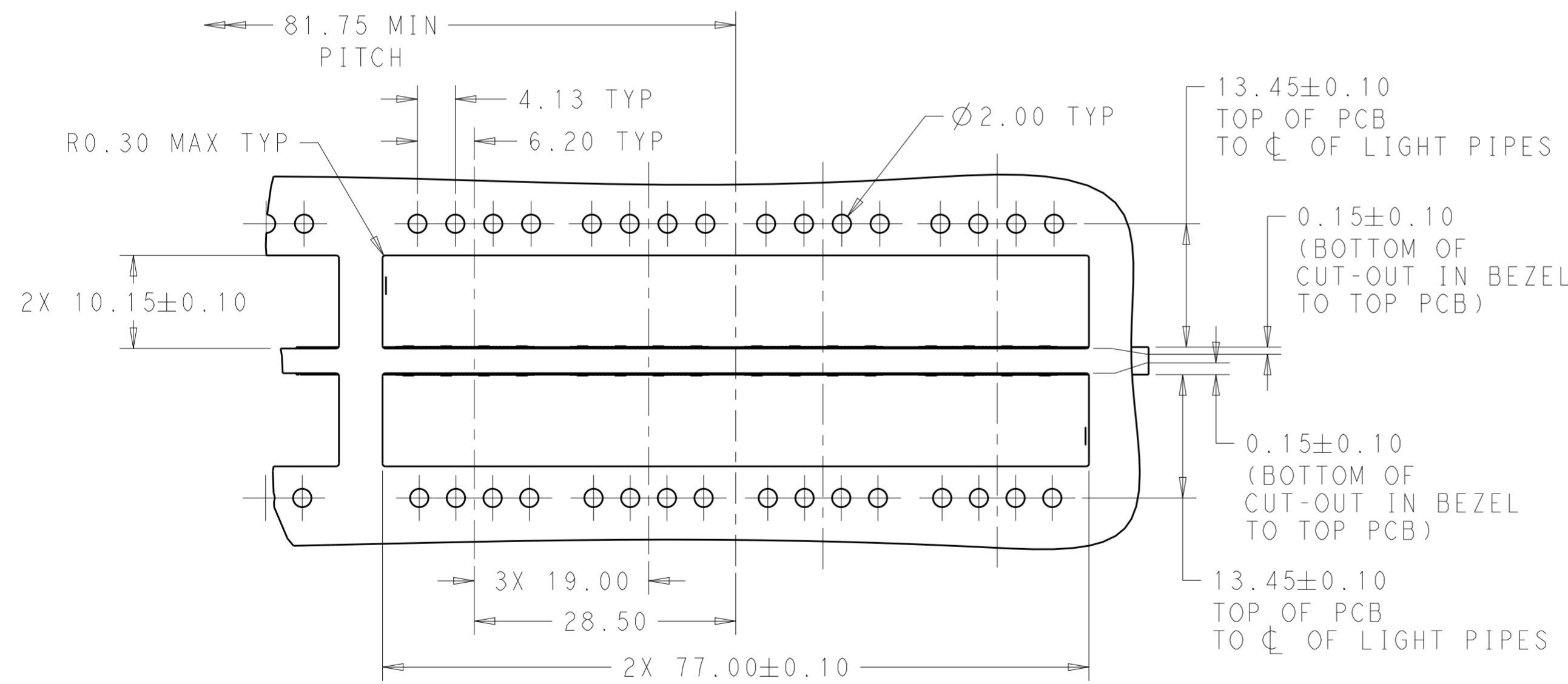

BELLY TO BELLY MOUNTING
SCALE 2:1

THIS DRAWING IS A CONTROLLED DOCUMENT.		DWN JASON YANG 20AUG2014	TE Connectivity	
		CHK SEAN HAN 31OCT2016		
DIMENSIONS:	TOLERANCES UNLESS OTHERWISE SPECIFIED:	APVD	NAME	
mm	0 PLC ± 1 PLC ±0.25 2 PLC ±0.2 3 PLC ± 4 PLC ±	PRODUCT SPEC	CAGE ASSEMBLY, QSFP28, 1X4 WITH HEAT SINKS AND LIGHT PIPES, THRU BEZEL, GASKET	
	ANGLES ±	APPLICATION SPEC	SIZE	CAGE CODE
MATERIAL	FINISH	WEIGHT	A200779	C-2170775
SEE NOTES material_2	SEE NOTES finish_spec_2	CUSTOMER DRAWING	SCALE 3:1	SHEET 4 OF 7

THIS DRAWING IS UNPUBLISHED. RELEASED FOR PUBLICATION 20
 © COPYRIGHT 20 BY - ALL RIGHTS RESERVED.

REVISIONS					
P	LTR	DESCRIPTION	DATE	DWN	APVD
-	-	SEE SHEET 1	-	-	-

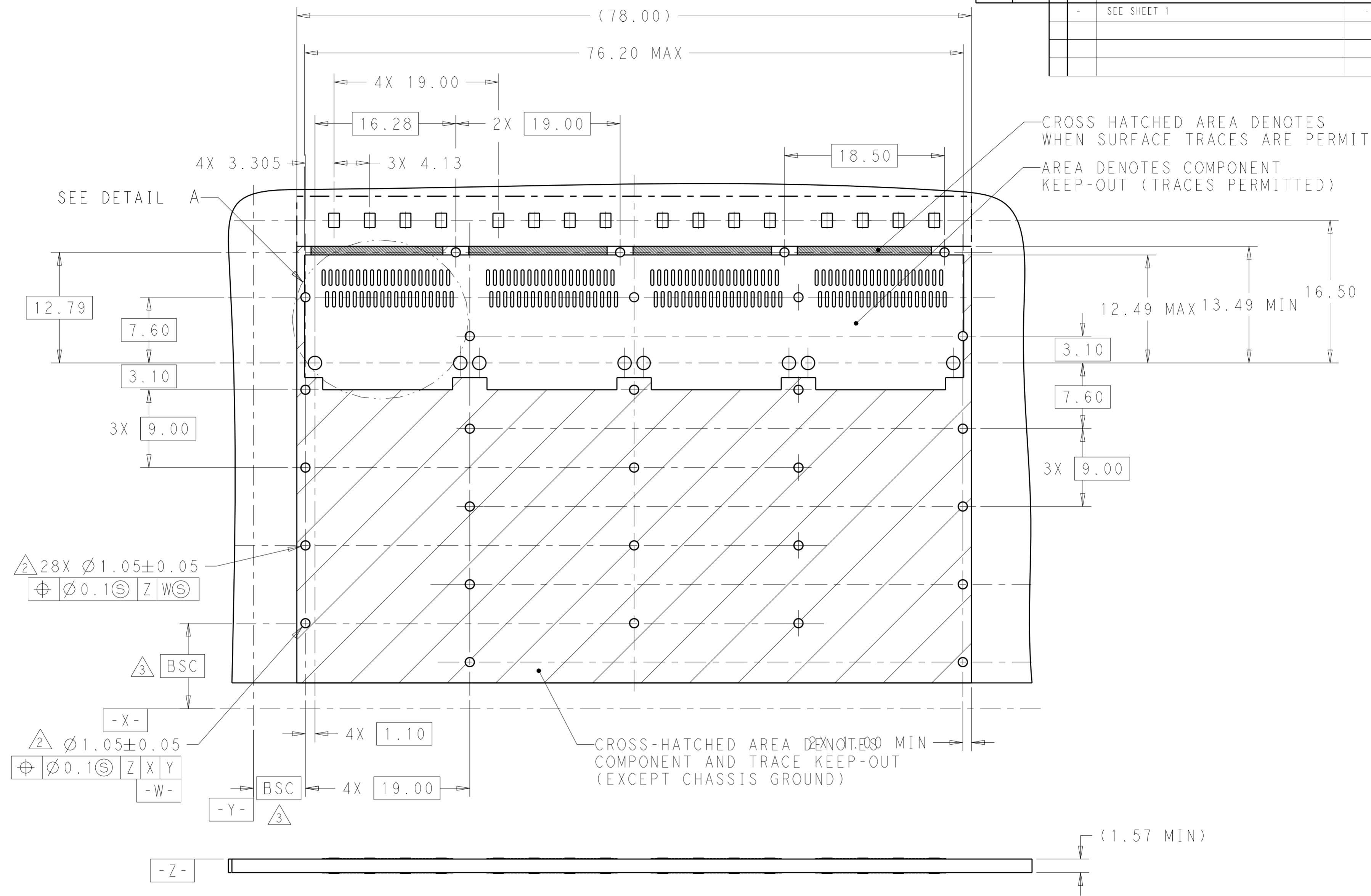

RECOMMENDED PCB LAYOUT
 SINGLE SIDE MOUNTED CONFIGURATION
 PCB TOLERANCE: ±0.05
 SCALE 3:1

THIS DRAWING IS A CONTROLLED DOCUMENT.		DWN JASON YANG 20AUG2014	TE Connectivity	
		CHK SEAN HAN 31OCT2016		
DIMENSIONS: mm		TOLERANCES UNLESS OTHERWISE SPECIFIED:		NAME CAGE ASSEMBLY, QSFP28, 1X4 WITH HEAT SINKS AND LIGHT PIPES, THRU BEZEL, GASKET
		0 PLC ± 1 PLC ±0.25 2 PLC ±0.2 3 PLC ± 4 PLC ± ANGLES ± FINISH SEE NOTES		PRODUCT SPEC APPLICATION SPEC WEIGHT SCALE 1:1 SHEET 5 OF 7 REV A
MATERIAL SEE NOTES material_2		FINISH SEE NOTES finish_spec_2		SIZE A200779
		CUSTOMER DRAWING		DRAWING NO C-2170775 RESTRICTED TO -

THIS DRAWING IS UNPUBLISHED. RELEASED FOR PUBLICATION 20
 © COPYRIGHT 20 BY - ALL RIGHTS RESERVED.

REVISIONS					
P	LTR	DESCRIPTION	DATE	DWN	APVD
-	-	SEE SHEET 1	-	-	-

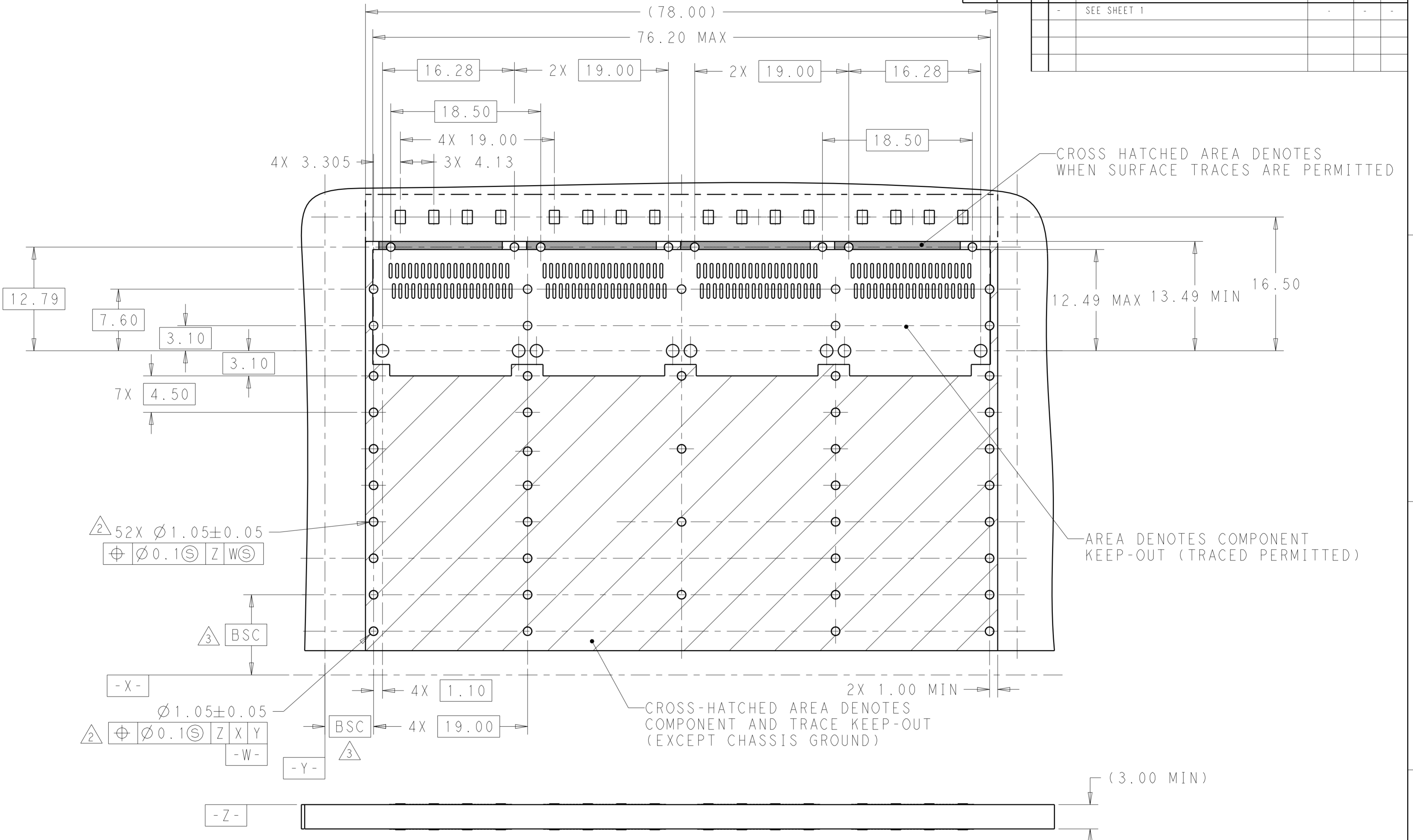

CROSS HATCHED AREA DENOTES WHEN SURFACE TRACES ARE PERMITTED

AREA DENOTES COMPONENT KEEP-OUT (TRACED PERMITTED)

CROSS-HATCHED AREA DENOTES COMPONENT AND TRACE KEEP-OUT (EXCEPT CHASSIS GROUND)

RECOMMENDED PCB LAYOUT
 BELLY TO BELLY MOUNTED CONFIGURATION
 PCB TOLERANCE: ±0.05
 SCALE 3:1

THIS DRAWING IS A CONTROLLED DOCUMENT.		DWN JASON YANG 20AUG2014	TE Connectivity	
		CHK SEAN HAN 31OCT2016		
DIMENSIONS: mm		TOLERANCES UNLESS OTHERWISE SPECIFIED:		NAME CAGE ASSEMBLY, QSFP28, 1X4 WITH HEAT SINKS AND LIGHT PIPES, THRU BEZEL, GASKET
		0 PLC ± 1 PLC ±0.25 2 PLC ±0.2 3 PLC ± 4 PLC ± ANGLES ± FINISH ±		SIZE A200779
MATERIAL SEE NOTES material_2		FINISH SEE NOTES finish_spec_2		DRAWING NO C-2170775
		CUSTOMER DRAWING		RESTRICTED TO -
		SCALE 1:1		SHEET 6 OF 7
				REV A

THIS DRAWING IS UNPUBLISHED. RELEASED FOR PUBLICATION 20
 © COPYRIGHT 20 BY - ALL RIGHTS RESERVED.

LOC	DIST	REVISIONS			
P	LTR	DESCRIPTION	DATE	DWN	APVD
-	-	SEE SHEET 1	-	-	-

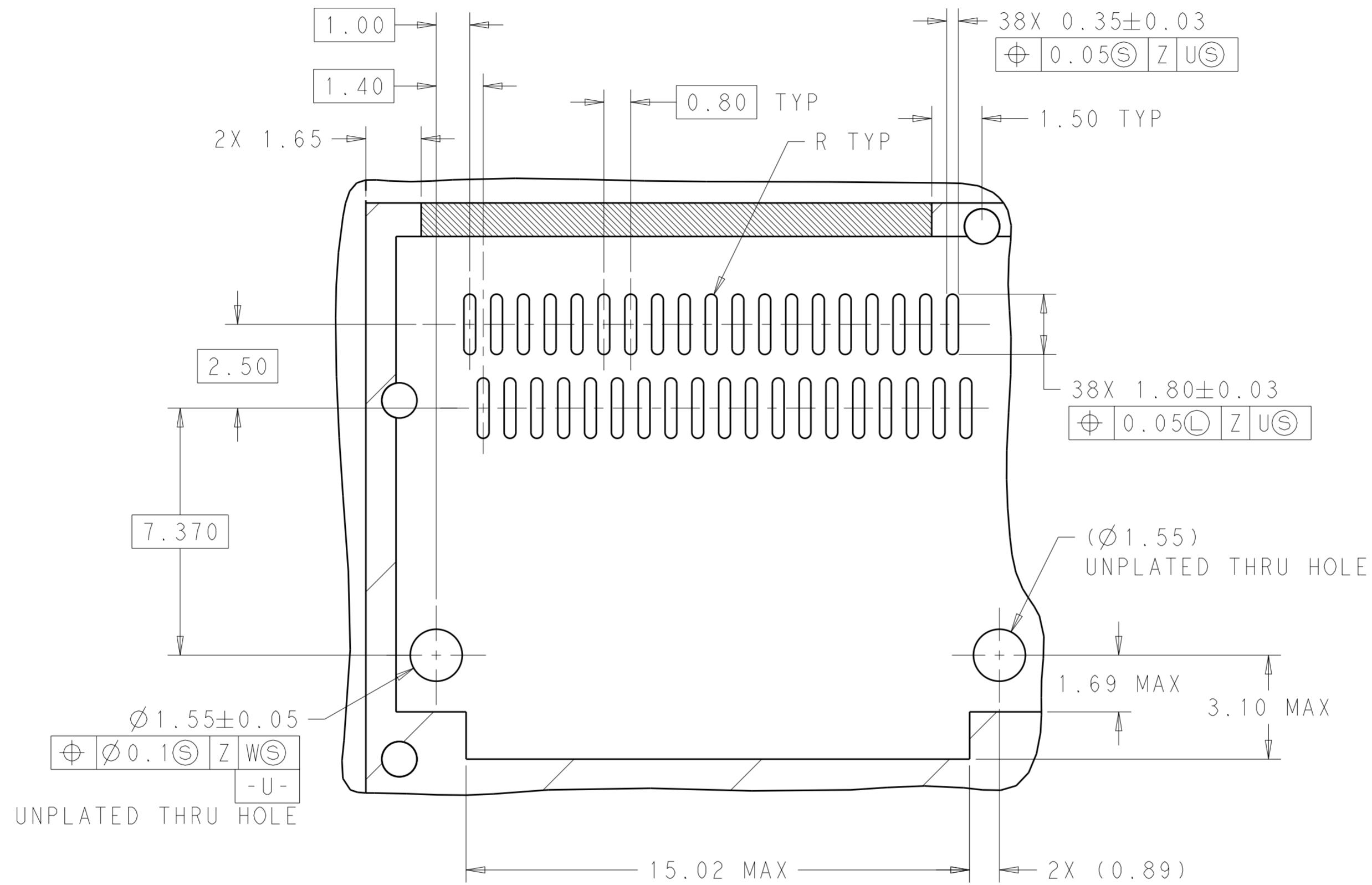

DETAIL A
 RECOMMENDED CONNECTOR LAYOUT
 (APPLIES TO ALL PCB LAYOUTS)
 4X INDIVIDUALLY
 SCALE 8:1

THIS DRAWING IS A CONTROLLED DOCUMENT.		DWN JASON YANG 20AUG2014	TE Connectivity													
		CHK SEAN HAN 31OCT2016														
DIMENSIONS: mm	TOLERANCES UNLESS OTHERWISE SPECIFIED:	APVD -	NAME CAGE ASSEMBLY, QSFP28, 1X4 WITH HEAT SINKS AND LIGHT PIPES, THRU BEZEL, GASKET													
<table border="1"> <tr><td>0 PLC</td><td>±</td></tr> <tr><td>1 PLC</td><td>±0.25</td></tr> <tr><td>2 PLC</td><td>±0.2</td></tr> <tr><td>3 PLC</td><td>±</td></tr> <tr><td>4 PLC</td><td>±</td></tr> <tr><td>ANGLES</td><td>±</td></tr> </table>	0 PLC	±	1 PLC	±0.25	2 PLC	±0.2	3 PLC	±	4 PLC	±	ANGLES	±	FINISH SEE NOTES	PRODUCT SPEC -	SIZE A200779	CAGE CODE C-2170775
0 PLC	±															
1 PLC	±0.25															
2 PLC	±0.2															
3 PLC	±															
4 PLC	±															
ANGLES	±															
MATERIAL SEE NOTES material_2	FINISH SEE NOTES finish_spec_2	APPLICATION SPEC -	WEIGHT -	RESTRICTED TO -												
CUSTOMER DRAWING		SCALE 1:1	SHEET 7 OF 7	REV A												

单击下面可查看定价，库存，交付和生命周期等信息

[>>TE Connectivity\(泰科\)](#)