

LOC	DIST	REVISIONS					
GP	00	P	LTN	DESCRIPTION	DATE	DWN	APVD
		A		PRODUCTION RELEASE	29FEB2016	JW	SH

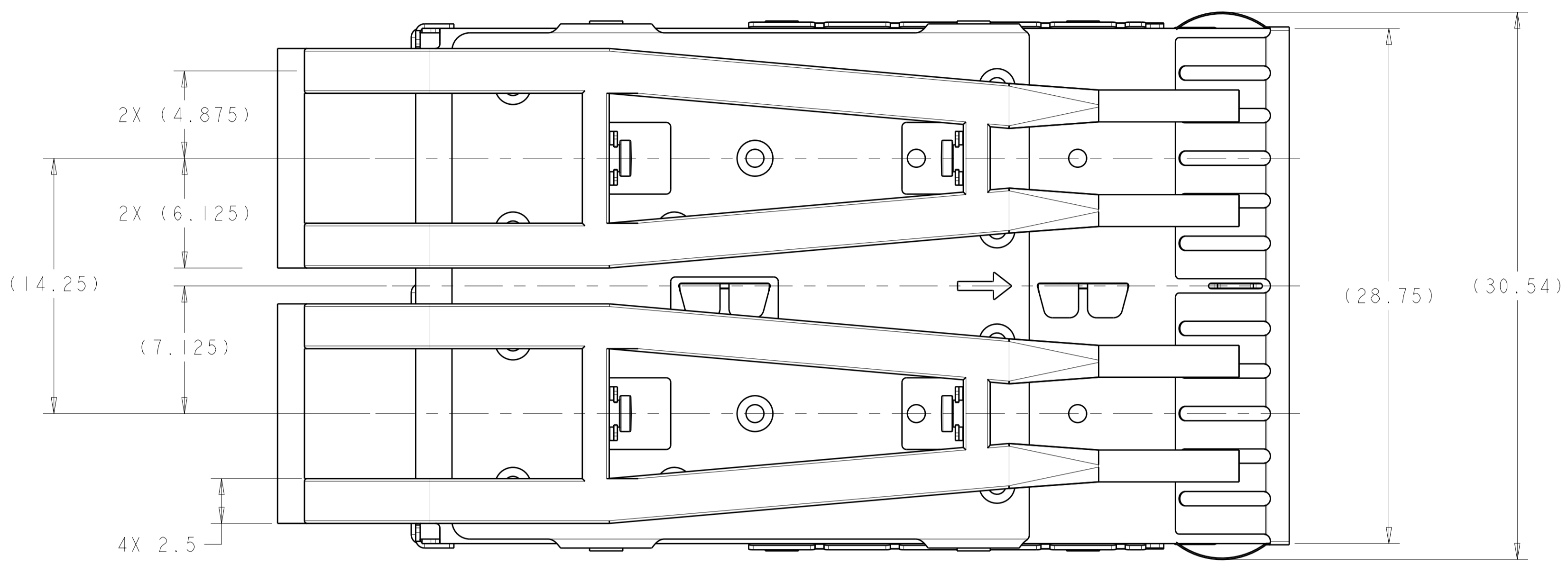

- 1 MATERIAL:  
CAGE ASSEMBLY: NICKEL SILVER ALLOY  
EMI SPRING: PHOSPHOR BRONZE  
LIGHT PIPE BRACKET: STAINLESS STEEL  
LIGHT PIPE: POLYCARBONATE, CLEAR.
- 2 DATUM AND BASIC DIMENSION ESTABLISHED BY CUSTOMER.
- 3. MATES WITH SFP MSA COMPLIANT TRANSCEIVERS.
- 4 PADS AND VIAS CHASSIS GROUND.
- 5. INTERPRETATION OF DATUM REFERENCE FRAME IN ACCORDANCE WITH SECT 4.4.1.1 OF ASME Y14.5M-1994.
- 6 MINIMUM PC BOARD THICKNESS:  
SINGLE SIDED: 1.45mm.
- 7 HOLE PATTERN REPEATS FOR EACH PORT, SPACING BETWEEN PORTS IS 14.25mm.
- 8 REFERENCE APPLICATION SPEC 114-13120, HOLE A, FOR RECOMMENDED DRILL HOLE DIAMETER AND PLATING THICKNESS.
- 9 REFERENCE APPLICATION SPEC 114-13120, HOLE B, FOR RECOMMENDED DRILL HOLE DIAMETER AND PLATING THICKNESS.
- 10 LIGHT PIPE ASSEMBLY SHIPPED UNASSEMBLED TO CAGE ASSEMBLY, CAGE ASSEMBLY TO BE PRESSED INTO THE PC BOARD PRIOR TO ATTACHING THE LIGHT PIPE ASSEMBLY TO THE CAGE ASSEMBLY.

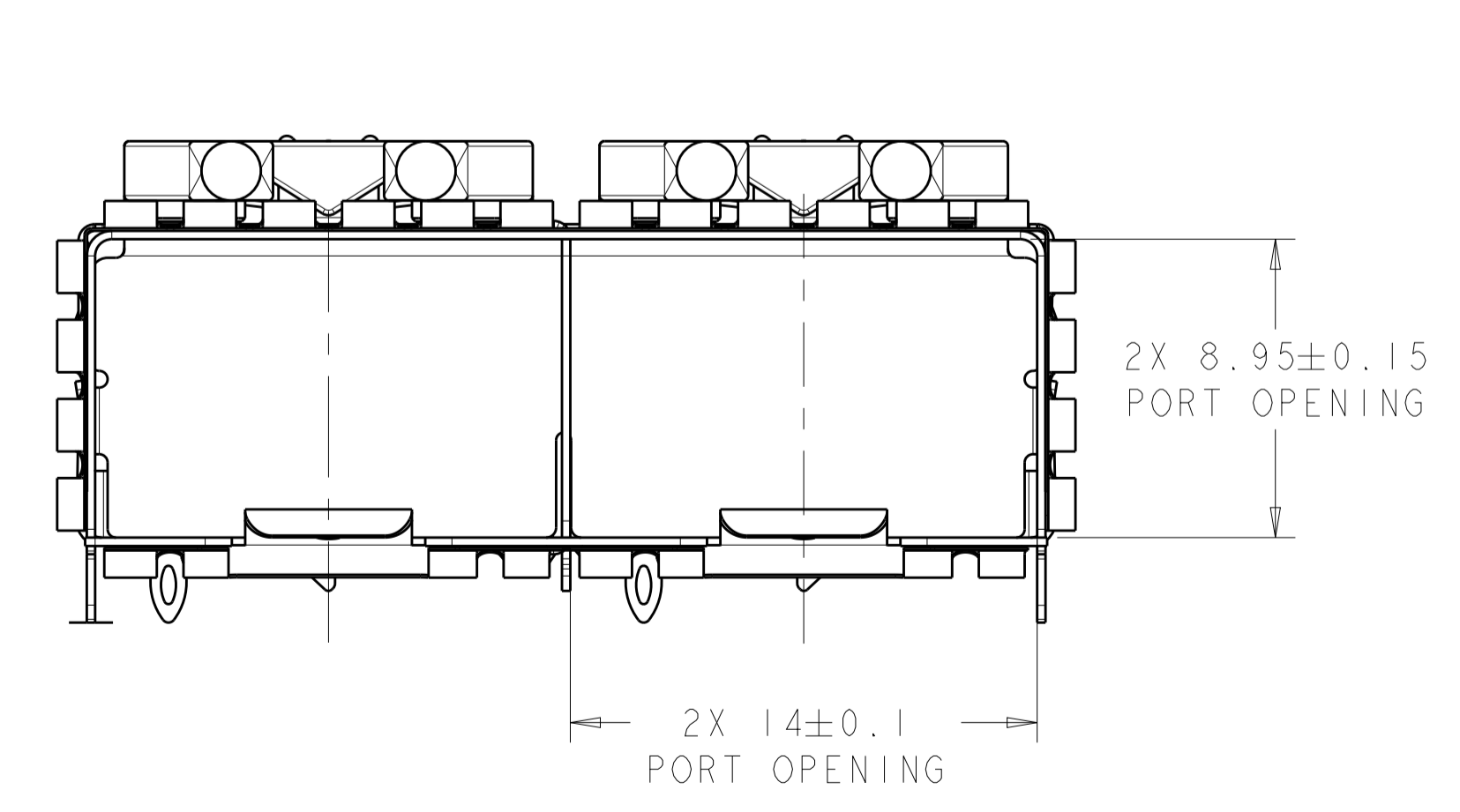
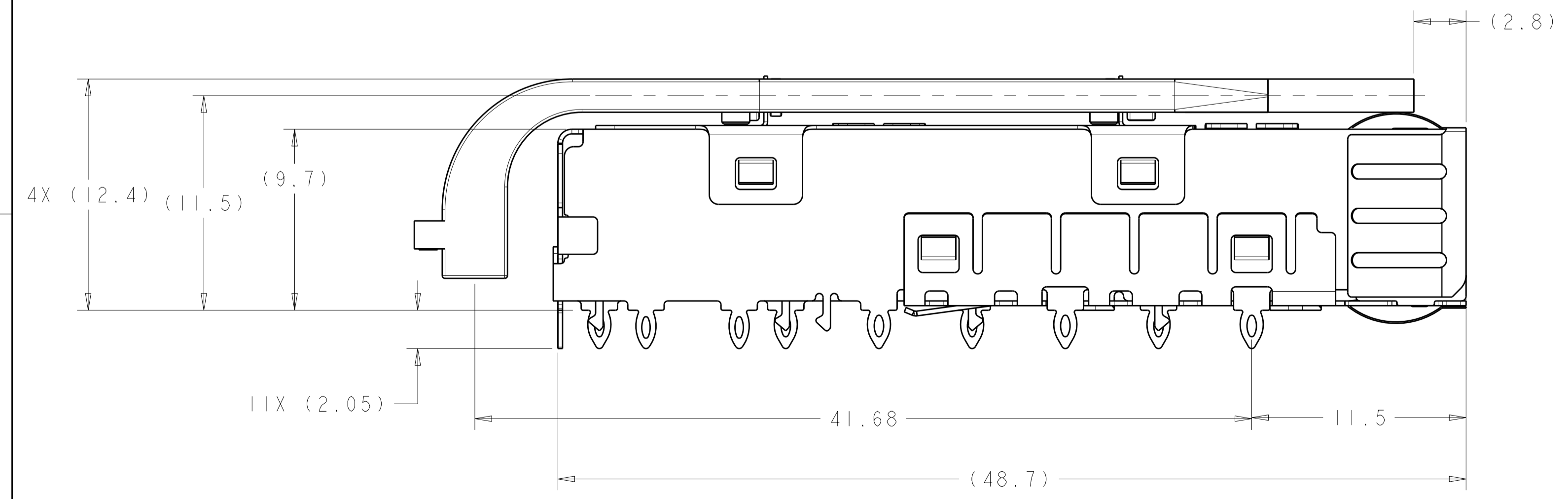
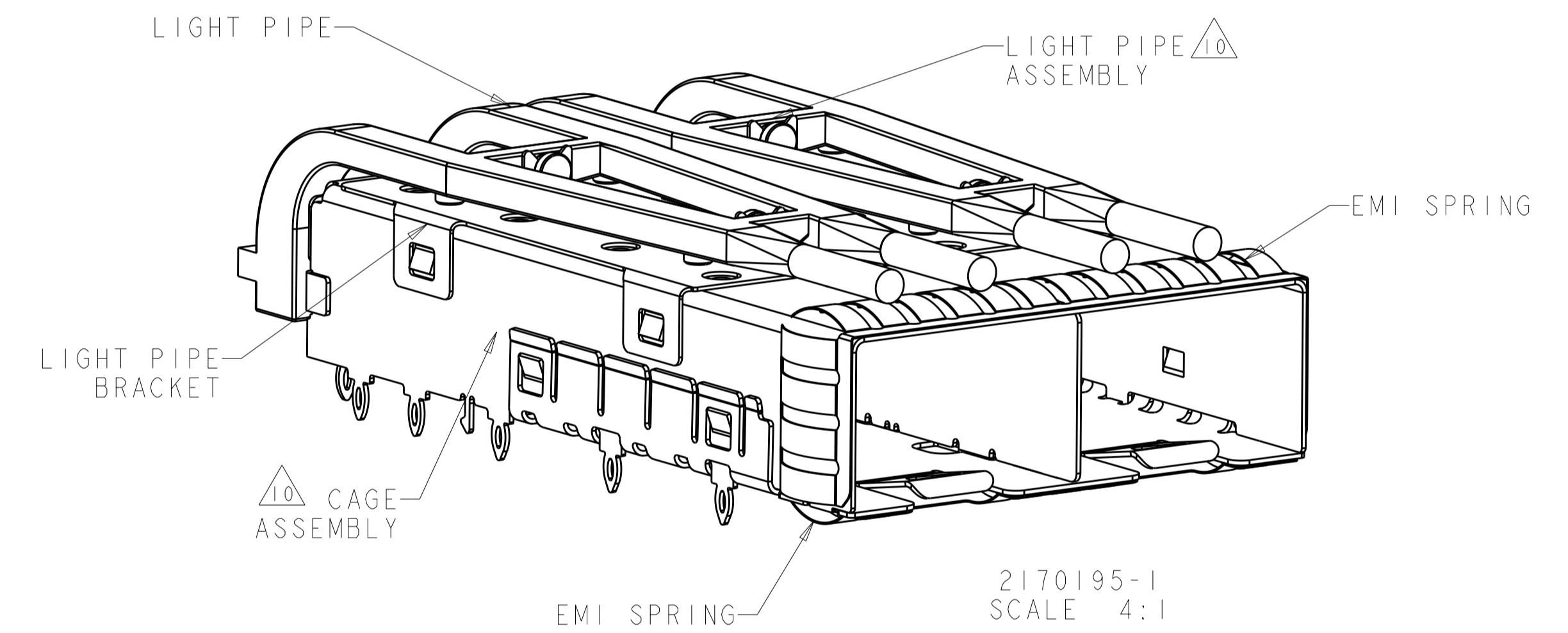

2170195-1  
PART NUMBER

THIS DRAWING IS A CONTROLLED DOCUMENT.		DWN: JASON YANG 23NOV2011	TE Connectivity	
DIMENSIONS: mm		CHK: ALEX CAI 23NOV2011		
TOLERANCES UNLESS OTHERWISE SPECIFIED:		APVD: ALEX CAI 23NOV2011	NAME: SFP+ 1X2 CAGE ASSEMBLY WITH LIGHT PIPES, PRESS FIT, EMI SPRING	
0 PLC	±0.2	PRODUCT SPEC	SIZE: CAGE CODE DRAWING NO. RESTRICTED TO	
1 PLC	±0.2	108-2364	A100779C=2170195	
2 PLC	±0.20	APPLICATION SPEC	SCALE: 5:1 SHEET 1 OF 3 REV A	
3 PLC	±	114-13120		
4 PLC	±	WEIGHT		
ANGLES	±0.3	CUSTOMER DRAWING		
MATERIAL	FINISH			

LOC	DIST	REVISIONS					
GP	00	P.	LTN	DESCRIPTION	DATE	DWN	APVD
-	-	-	-	SEE SHEET 1	-	-	-

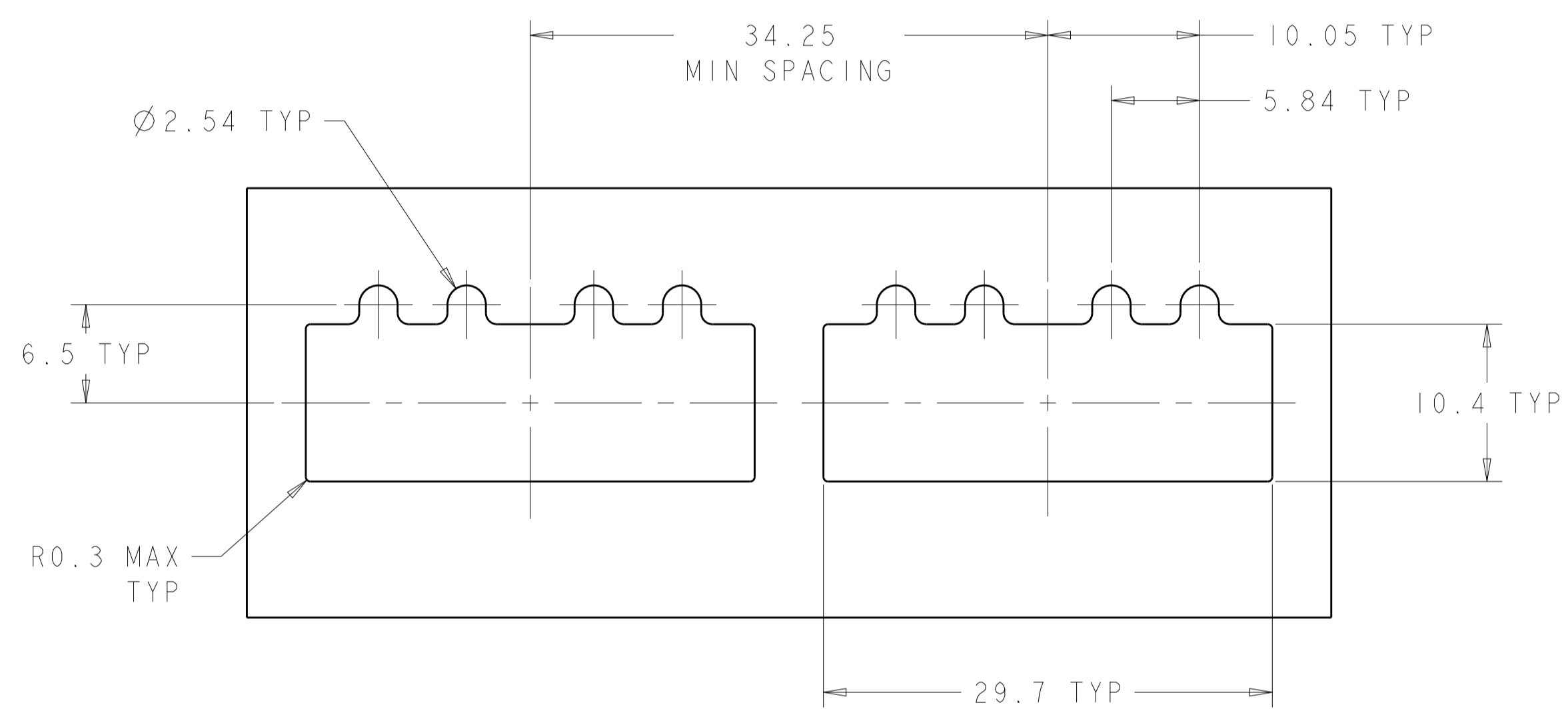

RECOMMENDED BEZEL CUT-OUT  
 PANEL TOLERANCE: ±0.1  
 SCALE 3:1

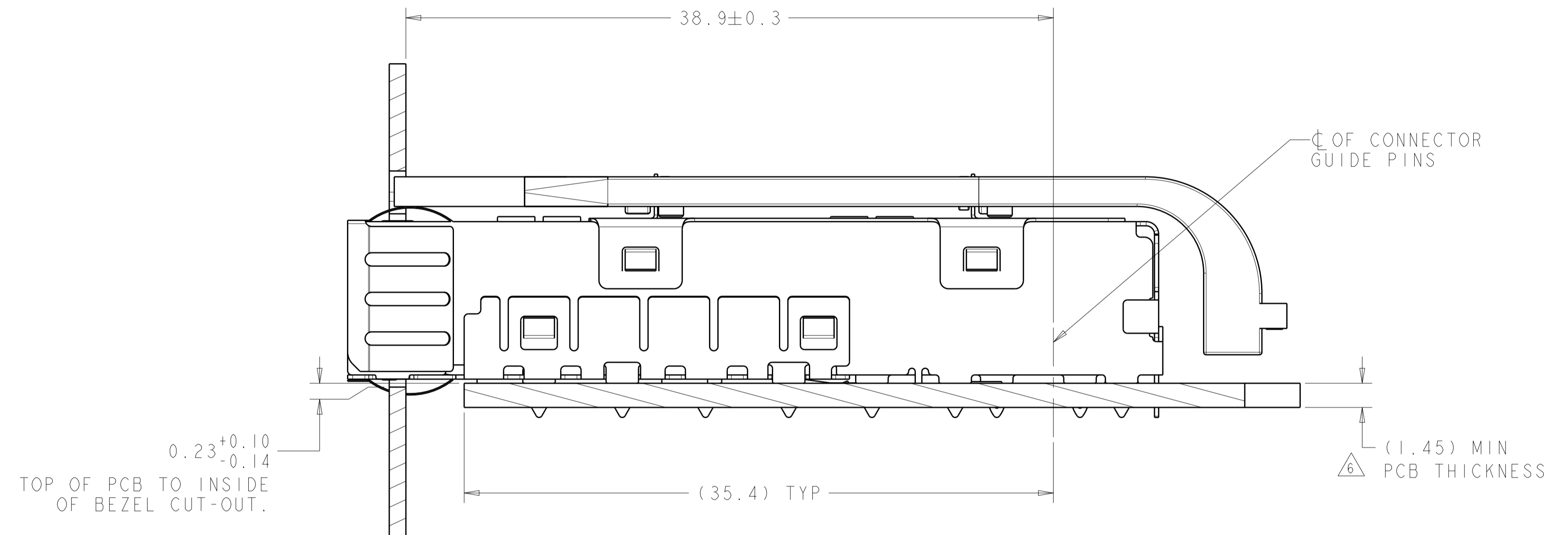

SECTION J-J  
 MOUNTED ON PCB  
 SHOWN THRU RECOMMENDED BEZEL

THIS DRAWING IS A CONTROLLED DOCUMENT.		DWN: JASON YANG 23NOV2011	
DIMENSIONS: mm		CHK: ALEX CAI 23NOV2011	
TOLERANCES UNLESS OTHERWISE SPECIFIED:		APVD: ALEX CAI 23NOV2011	NAME: SFP+ 1X2 CAGE ASSEMBLY WITH LIGHT PIPES, PRESS FIT, EMI SPRING
0 PLC	±0.2	PRODUCT SPEC	108-2364
1 PLC	±0.2	APPLICATION SPEC	114-13120
2 PLC	±0.20	SIZE	A100779
3 PLC	±	CAGE CODE	C=2170195
4 PLC	±	DRAWING NO	2170195
ANGLES	±	RESTRICTED TO	-
FINISH	±	SCALE	5:1
MATERIAL	-	SHEET	2 OF 3
CUSTOMER DRAWING	-	REV	A



单击下面可查看定价，库存，交付和生命周期等信息

[>>TE Connectivity\(泰科\)](#)