

4

3

2

1

THIS DRAWING IS UNPUBLISHED.

RELEASED FOR PUBLICATION

2011

© COPYRIGHT 2011 TE CONNECTIVITY

ALL RIGHTS RESERVED.

LOC B DIST -

REVISIONS

P	LTR	DESCRIPTION	DATE	DWN	APVD
	J	ECR-11-015626	04/08/11	JB	MG

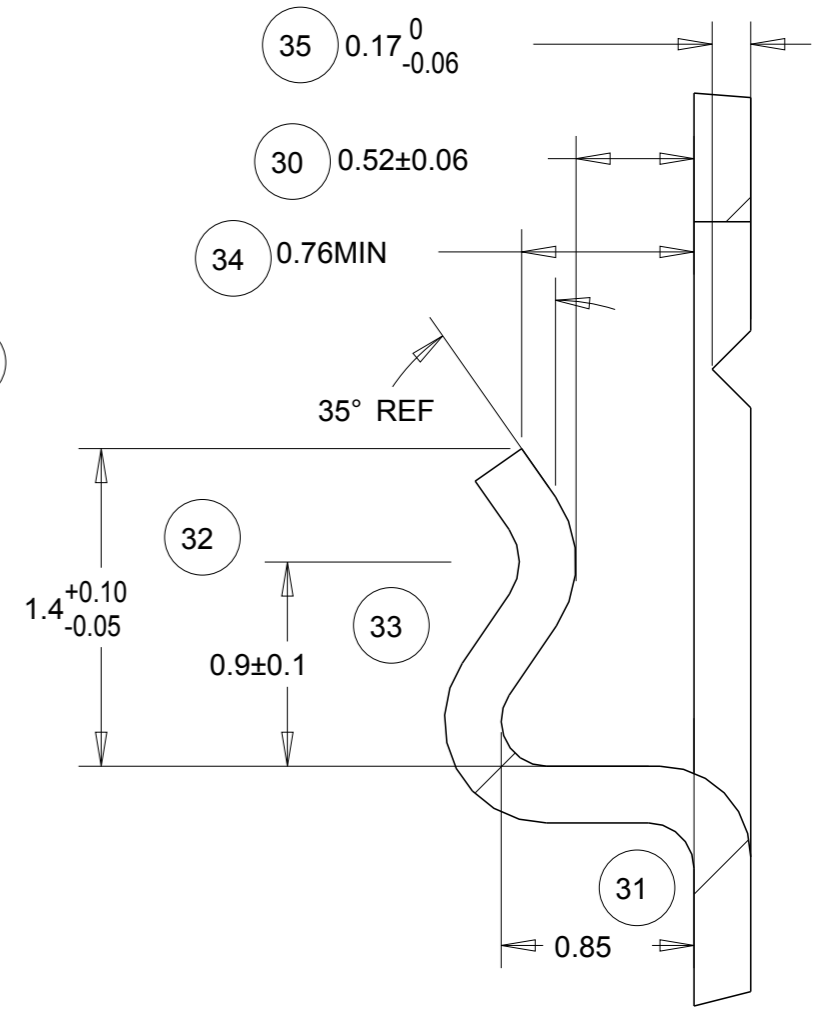
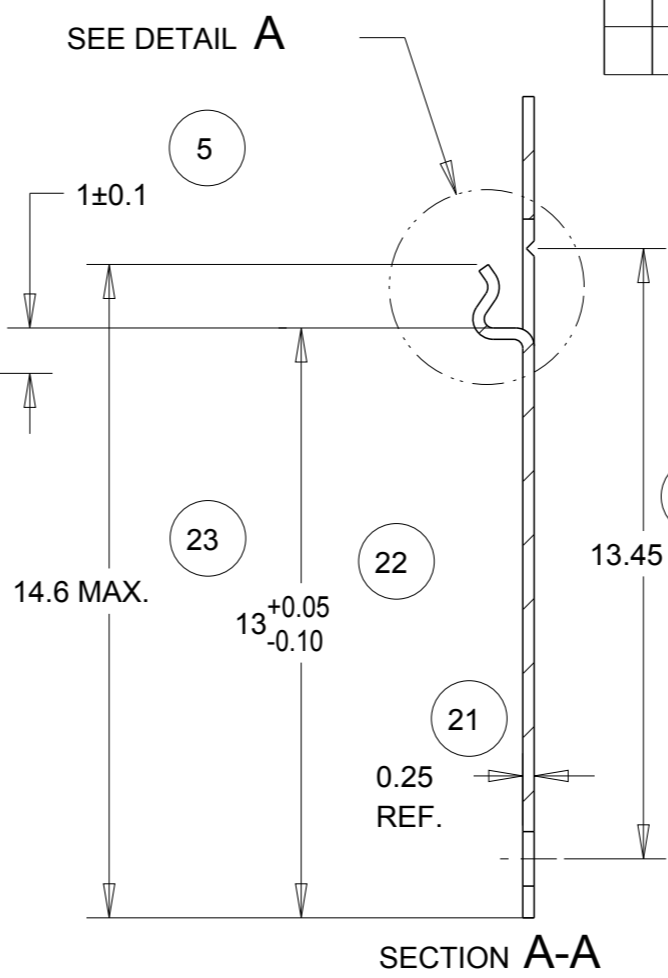
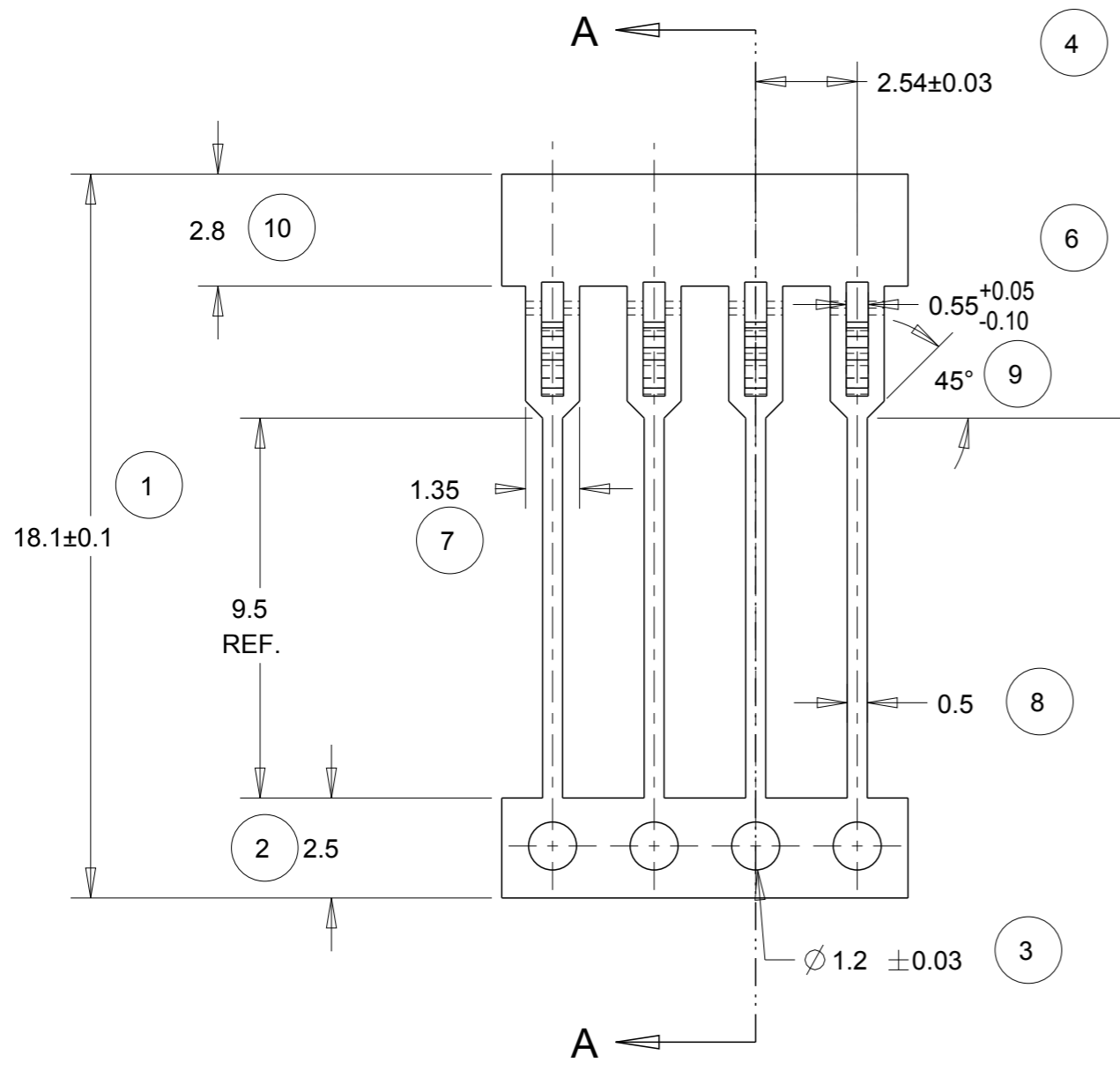

DETAIL A SCALE 30:1

NOTE
 BOWING: AFTER UPPER TIE BAR REMOVAL- 1.5mm MAX. FOR 500mm
 PITCH: AFTER UPPER TIE BAR REMOVAL- 2.54±0.127

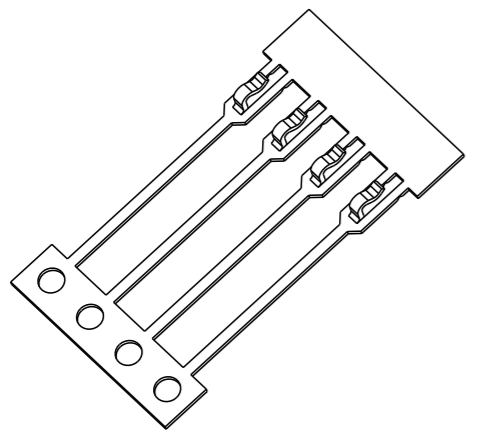

SCALE 3:1

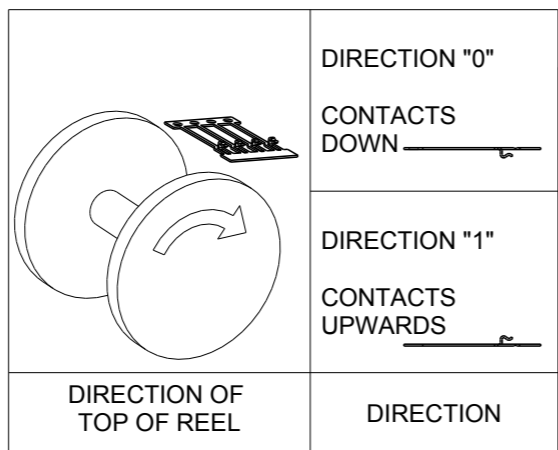

THIS DRAWING IS A CONTROLLED DOCUMENT.

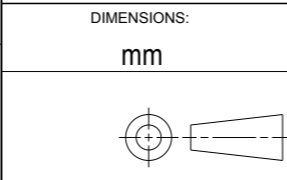

DIMENSIONS:	TOLERANCES UNLESS OTHERWISE SPECIFIED:
mm	
0 PLC	±-
1 PLC	±-
2 PLC	±0.05
3 PLC	±-
4 PLC	±-
ANGLES	±0.5
FINISH	-

MATERIAL SEE ABOVE.

DWN	J.BRIGHT	04/08/11
CHK	M.GREENER	04/08/11
APVD	D.PENNINGTON	04/08/11
PRODUCT SPEC	-	-
APPLICATION SPEC	-	-
WEIGHT	-	-

1	Ni & Sn	1544222-3
0	Ni & Sn	1544222-2
0	Sn	1544222-1
REELING	FINISH	PART NUMBER
STE TE Connectivity		
NAME SIL CONTACT		
SIZE	CAGE CODE	DRAWING NO
A3	00779	C -1544222
RESTRICTED TO		

CUSTOMER DRAWING SCALE NTS SHEET 1 OF 1 REV J

单击下面可查看定价，库存，交付和生命周期等信息

[>>TE Connectivity\(泰科\)](#)