

THIS DRAWING IS UNPUBLISHED. RELEASED FOR PUBLICATION
 © COPYRIGHT - By - ALL RIGHTS RESERVED.

REVISIONS					
P	LTR	DESCRIPTION	DATE	DWN	APVD
S1		REVISED PER ECO-14-001675	05FEB2014	NK	MZ
T		REVISED PER ECO-19-005830	15APR2019	RS	MZ

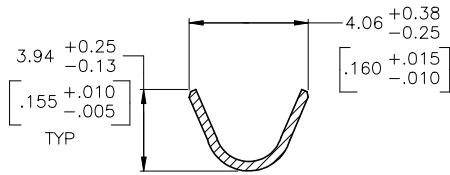

SECTION A-A

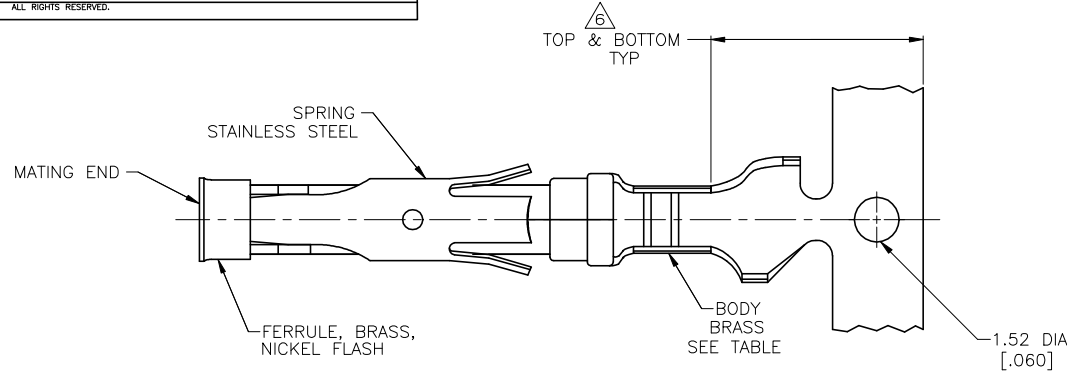
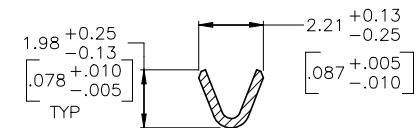
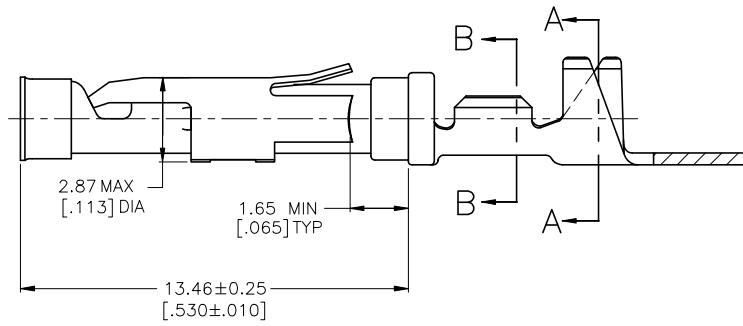
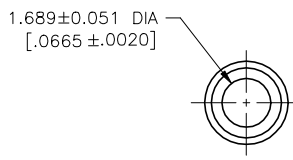

SECTION B-B

- 1 0.76µm [.000030] MIN GOLD PER MIL-G-45204 ON MATING END FOR A LENGTH OF 5.08 [.200] MIN WITH 1.27µm [.000050] MIN MATTE TIN PLATE IN WIRE CRIMP AREA, BOTH OVER 0.76µm [.000030] MIN NICKEL PER QQ-N-290.
- 2 1.27µm [.000050] MIN TIN-LEAD PER MIL-T-10727 OVER 0.76µm [.000030] MIN NICKEL PER QQ-N-290.
- 3 0.76µm [.000030] MIN GOLD PER MIL-G-45204 ON MATING END FOR A LENGTH OF 5.08 [.200] MIN WITH A UNIFORM GRADIENT TO 0.25µm [.000010] MIN GOLD PER MIL-G-45204 ON THE REMAINDER OVER 0.76µm [.000030] MIN NICKEL PER QQ-N-290.
- 4 0.38µm [.000015] MIN GOLD PER MIL-G-45204 ON MATING END FOR A LENGTH OF 5.08 [.200] MIN WITH 1.27µm [.000050] MIN MATTE TIN PLATE IN THE WIRE CRIMP AREA, BOTH OVER 0.76µm [.000030] MIN NICKEL PER QQ-N-290.
- 5 1.27µm [.000050] MIN GOLD PER MIL-G-45204 ON MATING END FOR A LENGTH OF 5.08 [.200] MIN WITH GOLD FLASH ON REMAINDER OVER 3.81µm [.000150] MIN NICKEL PER QQ-N-290.
- 6 GOLD PLATING NEED NOT APPEAR IN THIS AREA.
- 7 REVERSE REELED FOR MINI-APPLICATOR.
- 8 WIRE RANGE 24-20 AWG. INSULATION RANGE 1.52 [.060]-3.05 [.120].
- 9 0.38µm [.000015] MIN GOLD PER MIL-G-45204 ON MATING END FOR A LENGTH OF 5.08 [.200] MIN, 1.27µm [.000050] MIN TIN-LEAD PER MIL-T-10727 FOR A LENGTH OF 5.69 [.224] MIN ON OPPOSITE END, BOTH OVER 1.27µm [.000050] MIN NICKEL PER QQ-N-290 ON ENTIRE CONTACT.

10 1.27µm [.000050] MIN TIN PER MIL-T-10727 OVER 0.76µm [.000030] MIN NICKEL PER QQ-N-290.

	66565-7	7	10	1-66563-1
OBSELETE	66565-5	7	9	1-66563-0
OBSELETE	-	7	5	66563-9
	66565-4	7	1	66563-8
	66565-3	7	4	66563-7
	66565-2	7	2	66563-6
	66565-1	7	3	66563-5
	66565-4	STANDARD	1	66563-4
	66565-1	STANDARD	3	66563-1
	LOOSE PIECE REF	REELING	BODY FINISH	PART NO

THIS DRAWING IS A CONTROLLED DOCUMENT.

DWN: R. SHIREY 8-7-91
 CHK: R. STONE 9-19-91

APVD: J. WESTMAN 9-20-91

NAME: SOCKET ASSEMBLY, .062, TYPE III+

SIZE: A2 CAGE CODE: 00779 DRAWING NO: 66563

RESTRICTED TO: -

MATERIAL: SEE CALLOUTS FINISH: SEE CALLOUTS

WEIGHT: -

CUSTOMER DRAWING

SCALE: 8:1 SHEET: 1 of 1 REV: T

单击下面可查看定价，库存，交付和生命周期等信息

[>>TE Connectivity\(泰科\)](#)