

REVISIONS					
P	LTR	DESCRIPTION	DATE	DWN	APVD
	G	EC 0720-0279-93	6-18-93	SSG	BB
	G1	REVISED PER ECO-17-014333	16OCT2017	RS	DR

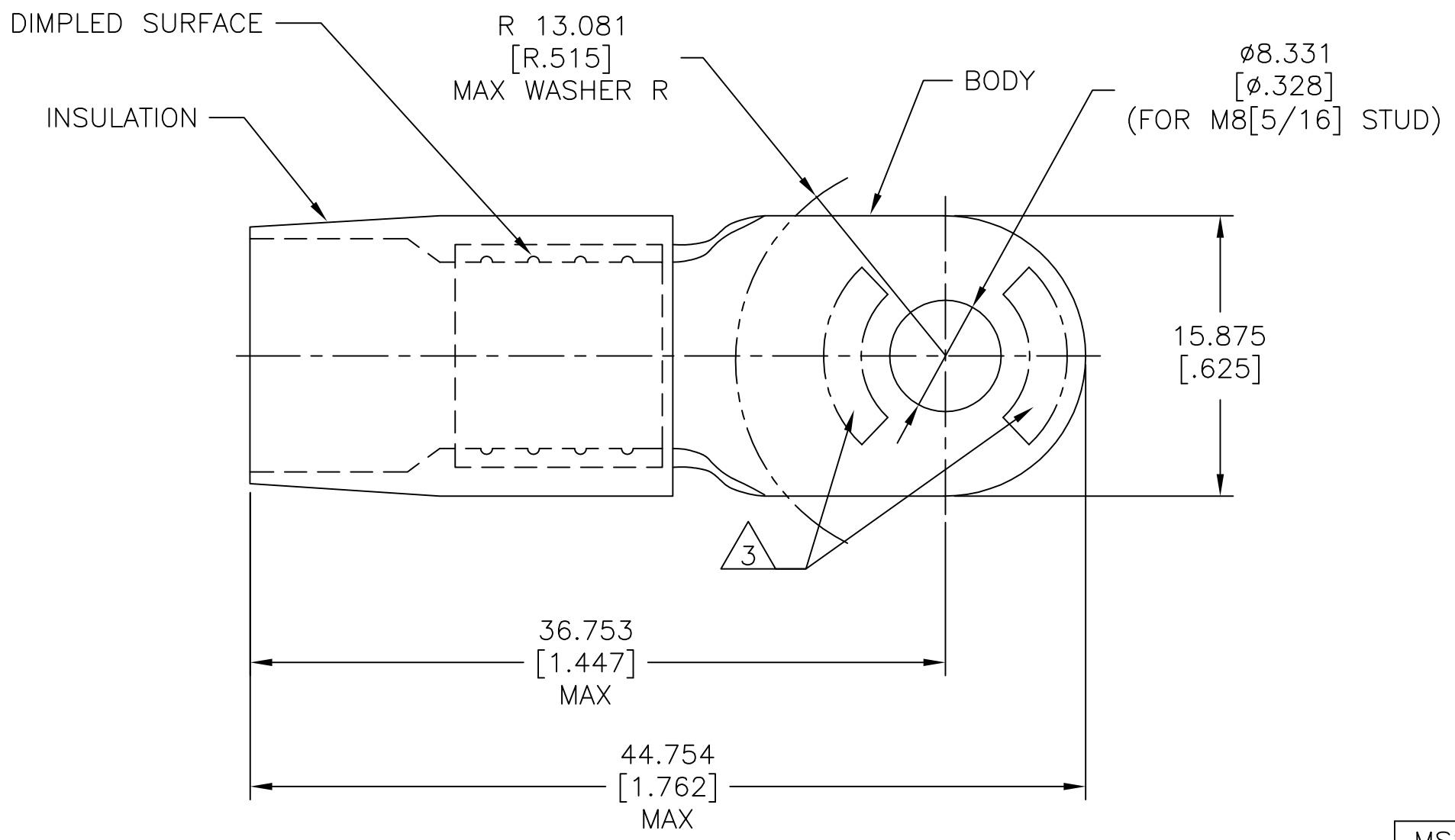
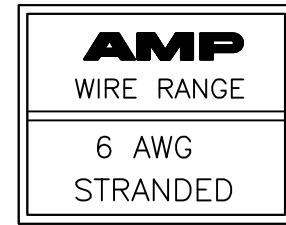

- 1 BODY MATERIAL THK 1.143±0.051[.045±.002]
- 2 FOR Ø7.975[Ø.314] MAX WIRE INS.
- 3 STAMP AMP 6\* 23-30 APPROX AS SHOWN.

MS25036-121 CLASS 2	100	LOOSE PC	324048
MILITARY P/N AND CLASS	QTY	PACKAGE TYPE	PART NO

AMP INCORPORATED CUSTOMER SERVICE SYSTEMS		MAX RECOMMENDED OPERATING TEMPERATURE: 105°C[221°F]	THIS DRAWING IS A CONTROLLED DOCUMENT.		DWN S.S. GOULDEN 6-18-93	TE Connectivity NAME TERMINAL, RING TONGUE, TERMINYL WIRE SIZE: 6 AWG				
FOR ADDITIONAL PRODUCT INFORMATION OR COPIES OF DRAWINGS AND TECHNICAL DOCUMENTS	PRODUCT INFORMATION CENTER 1-800-522-6752	VOLTAGE RATING: -	DIMENSIONS: mm [INCHES]	TOLERANCES UNLESS OTHERWISE SPECIFIED:	CHK R. HERSEY 6-18-93					SAE AS7928
FOR APPLICATION TOOLING INFORMATION	TOOLING ASSISTANCE CENTER 1-800-722-1111	CIRCULAR MIL AREA: 10.5-16.8mm <sup>2</sup> [20,800-33,100] STRANDED		0 PLC ± -	APVD B. BARE 6-18-93	APPLICATION SPEC				
FOR ORDER ENTRY	1-800-526-5142	THIS DRAWING IS A CONTROLLED DOCUMENT FOR AMP INCORPORATED. IT IS SUBJECT TO CHANGE AND THE CONTROLLING ENGINEERING ORGANIZATION SHOULD BE CONTACTED FOR THE LATEST REVISION.		MATERIAL BODY: COPPER PER ASTM B-152 INSULATION: NYLON ASTM D4066 TYPE I	1 PLC ± - 2 PLC ± - 3 PLC ± 0.127[.005] 4 PLC ± - ANGLES ± -	PRODUCT SPEC	SIZE	CAGE CODE	DRAWING NO	RESTRICTED TO
					FINISH BODY: TIN PLATE PER ASTM B545 INSULATION: COLOR-BLUE	WEIGHT	A3 00779		C=324048	
CUSTOMER DRAWING						SCALE	NTS	SHEET	1 OF 1	REV G1

单击下面可查看定价，库存，交付和生命周期等信息

[>>TE Connectivity\(泰科\)](#)