

LOC	DATE	REVISIONS		
AA	22			
REV	DESCRIPTION	DATE	BY	CHK
C1	REVISED PER ECO-11-005140	04APR11	RK	HMR
D	ECO-11-013930	30MAY2011	EL	LR

MECHANICAL:

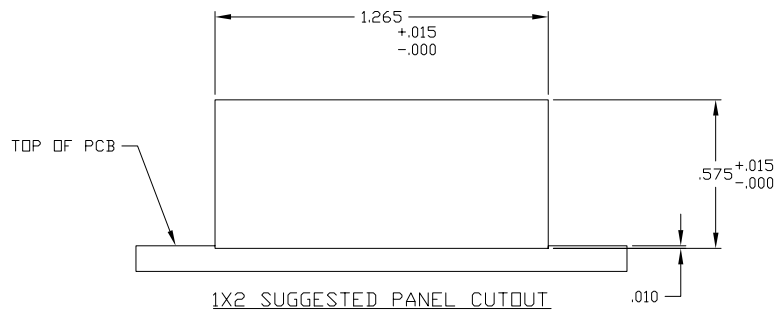
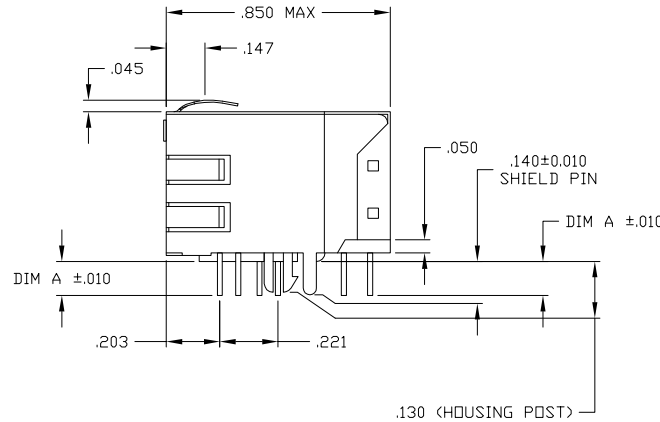
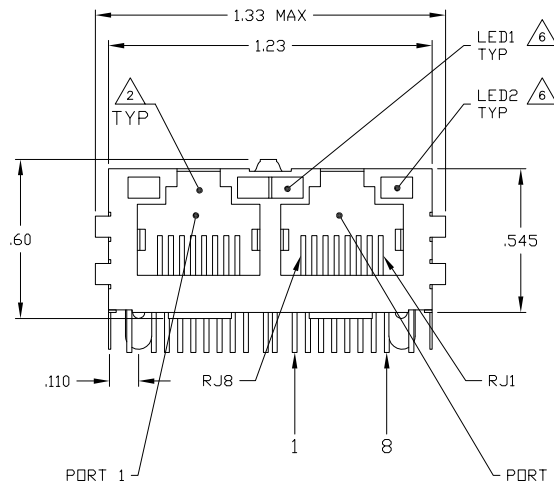
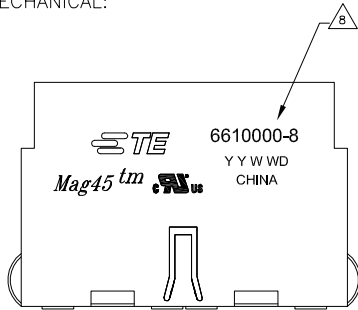

- 1 MATERIALS:
 -HOUSING - THERMOPLASTIC PET POLYESTER FLAMMABILITY RATING UL 94V-0
 -SHIELD - .010" THICK, C26800 BRASS PREPLATED WITH 30μINCH MIN SEMI-BRIGHT NICKEL.
 -SOLDER TABS THICK DIPPED WITH 100μINCH MIN SAC SOLDER.
 -MOD JACK CONTACTS - 0.0157 X 0.018" PHOSPHOR BRONZE, 50μINCH MIN OVERALL NICKEL UNDERPLATE WITH SELECT 50μINCH MIN HARD GOLD FINISH PLATE. SOLDER TAILS WITH 100μINCH MIN MATTE TIN AND/OR SAC SOLDER DIP.
 -LIGHT EMITTING DIODE(LED) - DIFFUSED EPOXY LENS, .020" X .020" CARBON STEEL WIREFRAME LEADS PRE-PLATED WITH 80μINCH SILVER OVER 40μINCH NICKEL UNDERPLATE OVER 40μINCH COPPER UNDERPLATE. POST-PLATED WITH 100μINCH MATTE TIN AND/OR SAC SOLDER DIP OR PURE TIN SOLDER DIP.
- 2 RJ45 JACK CAVITY CONFORMS TO FCC RULES AND REGULATIONS PART 68, SUB PART F.
- 3 MAGNETICS
 -IMPEDANCE: 100 OHMS
 -TURNS RATIO (CHIP-CABLE): TX = 11, RX = 11
 -OPEN CIRCUIT INDUCTANCE (OCL): 350μH MIN @100kHz, 0.1VRMS, 8mADC BIAS FROM 0°C TO 70°C, TX AND RX
 -PERFORMANCE @ 25°C:
 INSERTION LOSS (IL): 1.1dB MAX FROM 0.5MHz TO 100MHz
 RETURN LOSS (RL): 18dB MIN FROM 0.5MHz TO 30MHz
 18-20LOG(f/30)dB MIN FROM 30.1MHz TO 60MHz
 12dB MIN FROM 60.1MHz TO 80MHz
 CROSSTALK ATTENUATION: 35dB MIN FROM 0.5MHz TO 40MHz
 33-20xLOG(f/50)dB MIN FROM 40.1MHz TO 100MHz
 COMMON MODE REJECTION RATIO (CMRR): 30dB MIN FROM 0.5MHz TO 100MHz
 -ISOLATION VOLTAGE: 2250VDC (MAX) FOR 60 SECONDS WITH A RISE TIME OF 500V/SEC AND WITH ALL PORTS CONNECTED.
- 4 C1 IS AN OPTIONAL. IF NO CAPACITOR, TRACE IS CONTINUOUS. SEE TABLE FOR PRESENCE OF CAPACITOR IN DIFFERENT CONFIGURATIONS.
- 5 OPERATING TEMPERATURE FROM 0° TO +70°C
- 6 THE 250 OHM LED RESISTORS ARE OPTIONAL, PLEASE SEE CHART FOR PRESENCE OR ABSENCE OF LED RESISTORS. IF THE LED WITHOUT 250 OHM RESISTORS, LED IS DRIVEN WITH CONSTANT CURRENT AT APPROX 20mA
 LED COLOR: DOMINANT WAVELENGTH (λD): GREEN 568 nm TYP. @ IF=20mA
 FORWARD VOLTAGE (VF): GREEN 2.2V TYP. @ IF=20mA
 DOMINANT WAVELENGTH (λD): YELLOW 588 nm TYP. @ IF=20mA
 FORWARD VOLTAGE (VF): YELLOW 2.1V TYP. @ IF=20mA
 DOMINANT WAVELENGTH (λD): ORANGE 605 nm TYP. @ IF=20mA
 FORWARD VOLTAGE (VF): ORANGE 2.05V TYP. @ IF=20mA
 IF THE LED WITH 250 OHM RESISTORS, LED IS DRIVEN WITH 5V VOLTAGE AND THE MAX OPERATING CURRENT IS 20mA.
 LED COLOR: DOMINANT WAVELENGTH (λD): GREEN 568 nm TYP. @ VF=5V
 FORWARD CURRENT (IF): GREEN 12 mA TYP. @ VF=5V
 DOMINANT WAVELENGTH (λD): YELLOW 588 nm TYP. @ VF=5V
 FORWARD CURRENT (IF): YELLOW 13 mA TYP. @ VF=5V
- 7 INDICATED CONNECTIONS ARE FOR NIC CONFIGURATION. THE MAGNETICS ARE SYMMETRICAL AND SUPPORT AUTO-MDI/MDX.
- 8 TE CONNECTIVITY LOGO, TE CONNECTIVITY PART NUMBER, DATE CODE, COUNTRY OF ORIGIN AND AGENCY APPROVAL MARKING IN APPROXIMATE LOCATION SHOWN.
9. THESE PARTS ARE RECOMMENDED FOR WAVE SOLDERING PROCESS, PEAK WAVE SOLDERING TEMPERATURE IS 265°C, 10SECONDS MAX.

0.087	YES	YES	GREEN	YELLOW	7-6610000-1
0.145	YES	YES	GREEN	GREEN	6-6610000-1
0.145	YES	YES	GREEN	YELLOW	5-6610000-1
0.145	NO	NO	GREEN	YELLOW	6610000-8
DIM A	LED RESISTOR	DECOUPLING CAPACITOR	LED1	LED2	PART NUMBER

THIS DRAWING IS A CONTROLLED DOCUMENT.

REV: VARELA - 10MAR2003
 CHK: FAROLE - 10MAR2003
 D: FAROLE - 10MAR2003

TE Connectivity

1X2 MAC45(TM) MODULAR JACK, 7N2 SCHEMATIC, 26 SERIES CIRCUIT, SHIELDED, WITH LEDs

108-2100

SIZE: A1 | DATE CODE: 00779 | DRAWING NO: C-6610000 | RESTRICTED TO: CUSTOMER DRAWING

SCALE: 4:1 | SHEET: 1 of 2 | REV: D

726 SERIES MAGNETIC CIRCUIT $\triangle 3/7$

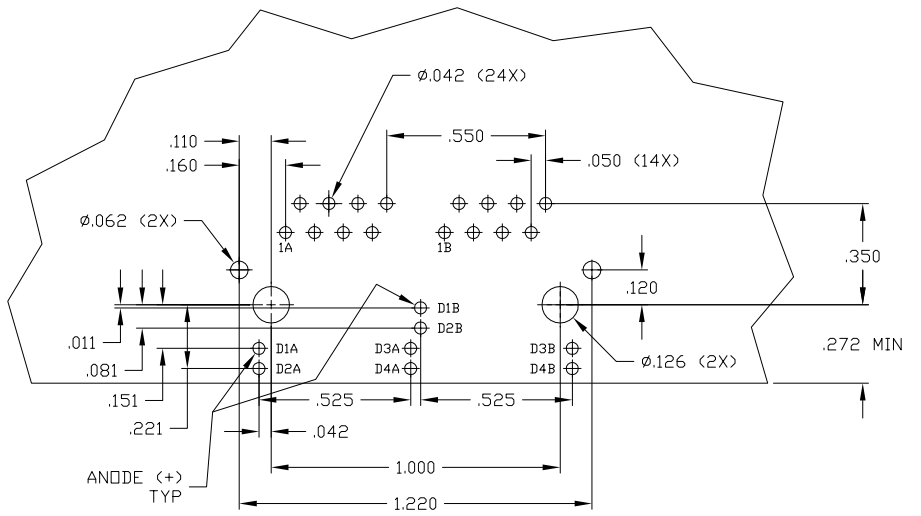
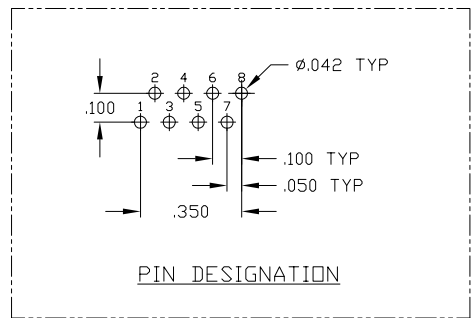
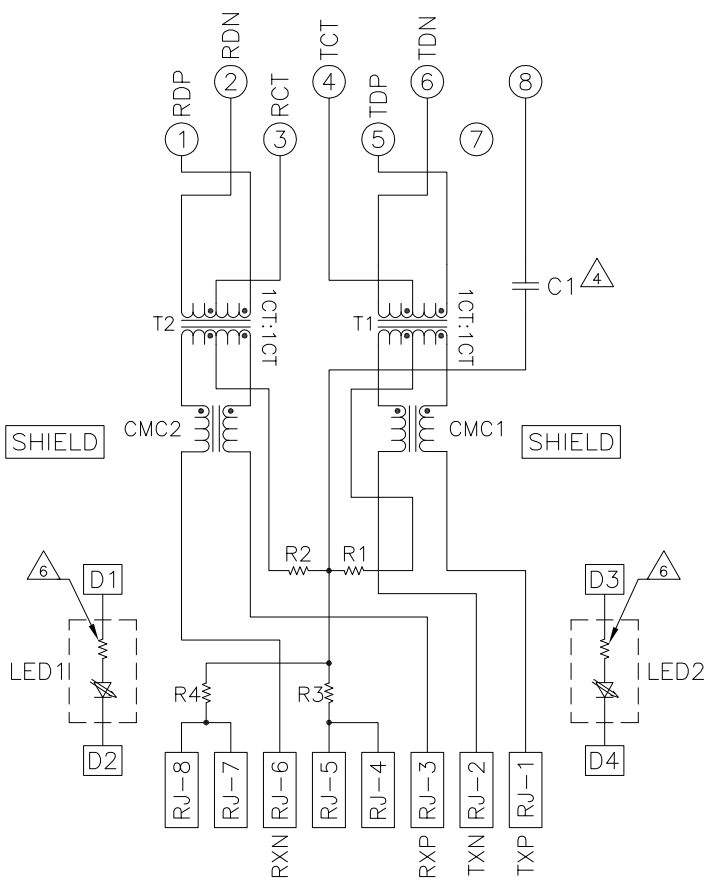

SUGGESTED PCB LAYOUT
(Component Side)

THIS DRAWING IS A CONTROLLED DOCUMENT.		REV	1	VARELA	10MMR2008	NAME	1X2 MCA45(TM) MODULAR JACK,
DIMENSIONS:		CHK	2	FAROLE	10MMR2008	PRODUCT SPEC	7N2 SCHEMATIC, 26 SERIES CIRCUIT, SHIELDED,
INCHES	0.125	APP	3	FAROLE	10MMR2008	APPLICATION SPEC	WITH LEADS
	0.250	MATERIAL				SIZE	A1
	0.500	FINISH				CAGE CODE	00779
	1.000					DRAWING NO	C=6610000
	2.000					RESTRICTED TO	
	4.000					SCALE	4:1
	MILLIMETERS					SHEET	2 of 2
						REV	D

单击下面可查看定价，库存，交付和生命周期等信息

[>>TE Connectivity\(泰科\)](#)