

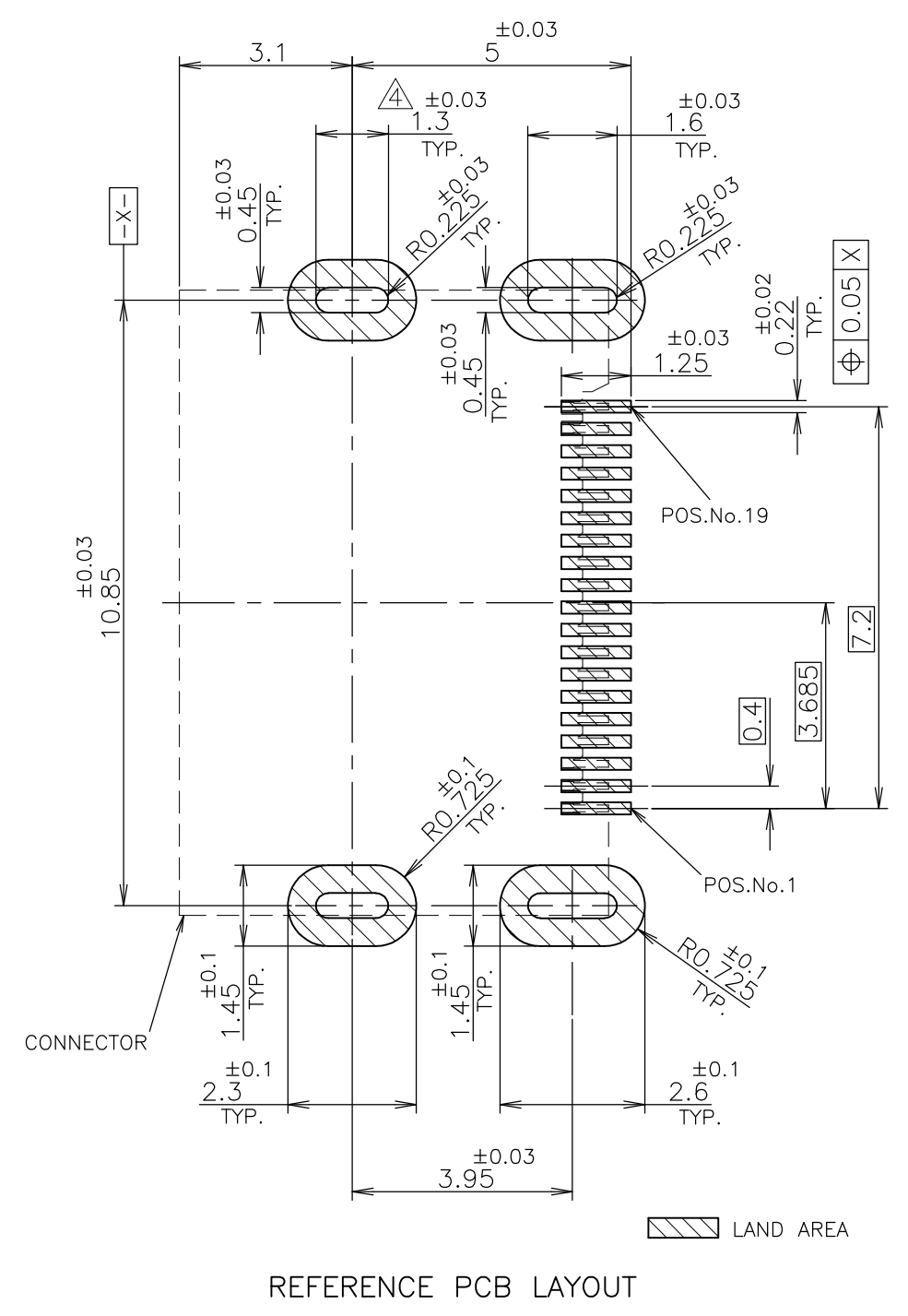

THIS DRAWING IS UNPUBLISHED. RELEASED FOR PUBLICATION  
 © COPYRIGHT - By - ALL RIGHTS RESERVED.

LOC	DIST	REVISIONS		
J		P	LTR	DESCRIPTION
		-		SEE SHEET 1
				DATE
				DWN
				APVD

2013978-2;AS SHOWN

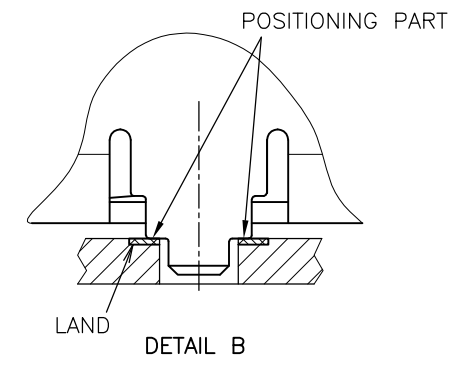
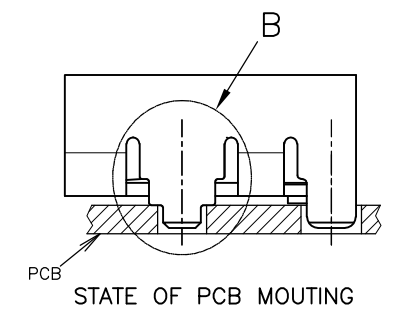
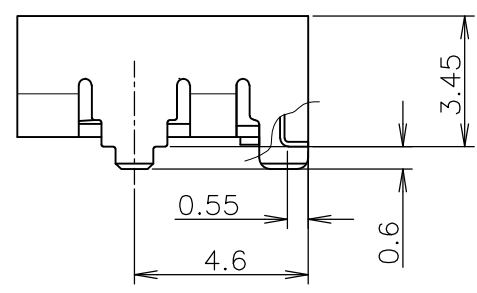
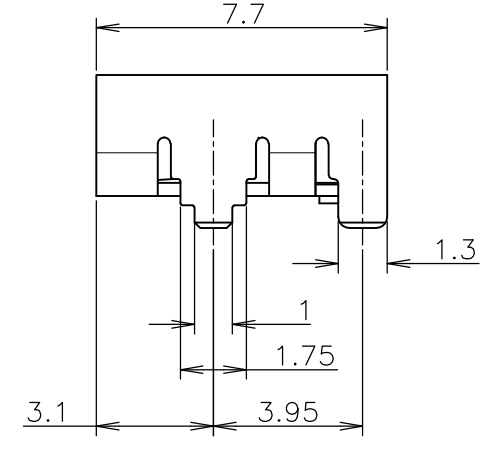
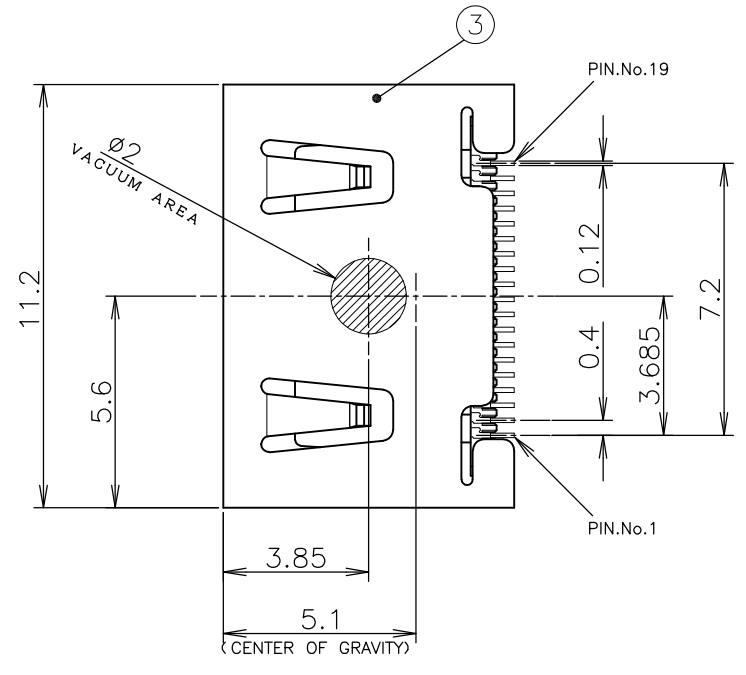
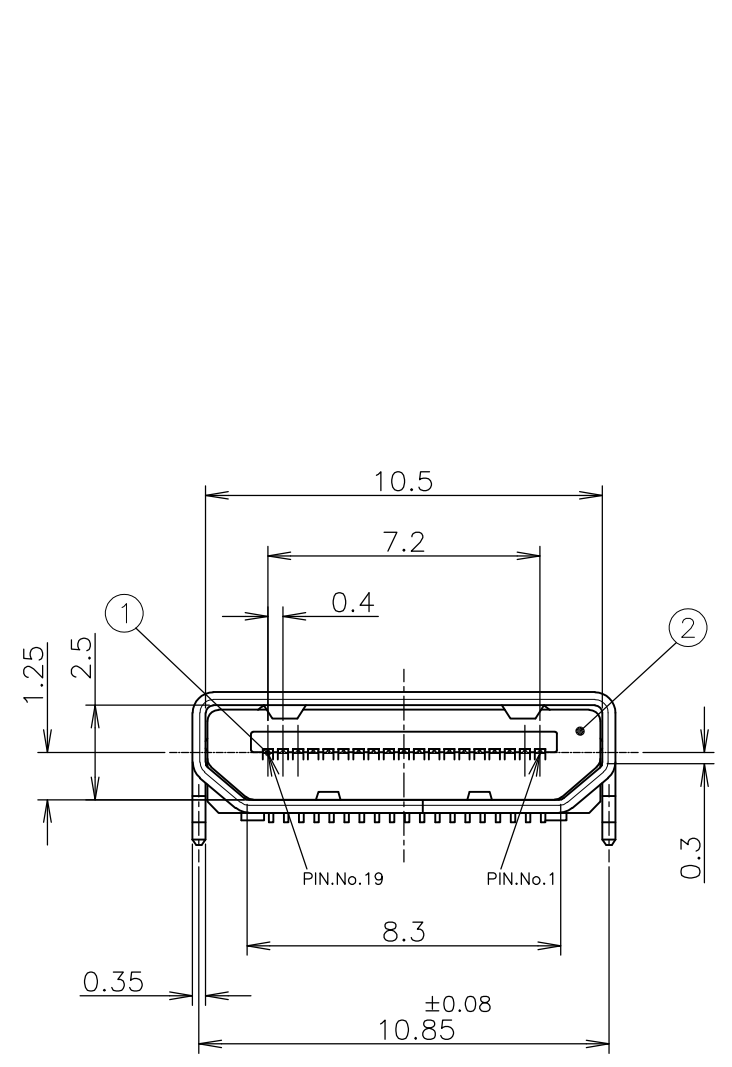

NOTE  
 1 GENERAL TOLERANCE : ±0.3  
 2 CONTACT TINE COPLANALITY ; 0.1mmMAX  
 3 FINISH  
 CONTACT ; Ni UNDER PLATING ALL OVER  
 1.3um MIN.  
 Au PLATING ON SOLDERING AREA  
 0.05um MIN.  
 Au PLATING ON CONTACT AREA  
 0.1um MIN.  
 SHELL ; Ni UNDER PLATING ALL OVER  
 0.8um MIN.  
 Sn PLATING ALL OVER  
 0.75um MIN.  
 4 PLEASE OBSERVE THE TOLERANCE SO THAT  
 THIS DIMENSION INFLUENCE POSITIONING  
 THE PRODUCT(REFER TO DETAIL A,B).

注記  
 1 一般公差 : ±0.3  
 2 コプラナリティ : 0.1mmMAX.  
 3 仕上げ  
 コンタクト : 全面ニッケル下地 1.3um 以上  
 はんだ付け部 金フラッシュメッキ  
 0.05um 以上  
 接点部 金メッキ 0.1um 以上  
 シェル : 全面ニッケル下地 0.8um 以上  
 全面スズメッキ 0.75um 以上  
 4 本寸法は製品の位置決めに影響する寸法  
 ですので、公差を厳守してください  
 (DETAIL A,Bを参照ください)

SMT TERMINAL

THIS DRAWING IS A CONTROLLED DOCUMENT.		DWN	TE Connectivity		
DIMENSIONS: 単位: 耗 mm		CHK			
TOLERANCES UNLESS OTHERWISE SPECIFIED: 一般公差		APVD	NAME 名称		
0 PLC ±		PRODUCT SPEC 製品規格	HDMI TYPE C RECEPTACLE CONNECTOR		
1 PLC ±		APPLICATION SPEC 取付適用規格	SIZE	CAGE CODE	DRAWING NO 番号
2 PLC ±		WEIGHT 0.62g	A3	00779	C-2013978
3 PLC ±		CUSTOMER DRAWING	RESTRICTED TO		
4 PLC ±		SCALE 尺度 5:1	SHEET 2 OF 5		REV B1
ANGLES ±					
FINISH 仕上					
MATERIAL 材料					

THIS DRAWING IS UNPUBLISHED.

RELEASED FOR PUBLICATION

© COPYRIGHT - By -

ALL RIGHTS RESERVED.

LOC J DIST

REVISIONS

変更

DESCRIPTION

DATE

DWN

APVD

SEE SHEET 1

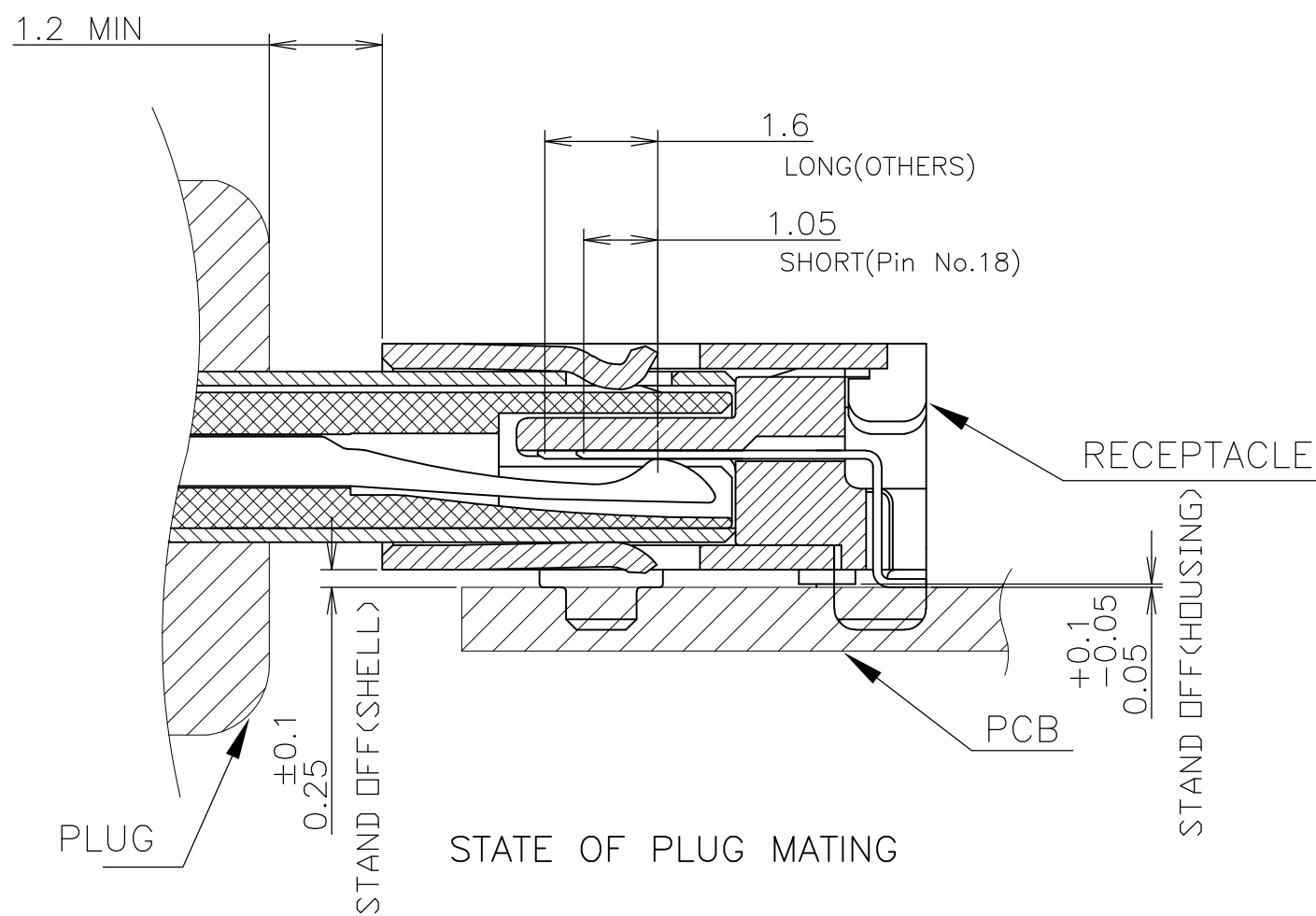

STATE OF PLUG MATING

THIS DRAWING IS A CONTROLLED DOCUMENT.

DIMENSIONS: 单位: 耗 mm

TOLERANCES UNLESS OTHERWISE SPECIFIED: 一般公差

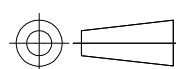

- 0 PLC ±
- 1 PLC ±
- 2 PLC ±
- 3 PLC ±
- 4 PLC ±
- ANGLES ±
- FINISH 仕上

MATERIAL 材料



DWN  
CHK  
APVD  
PRODUCT SPEC 製品規格  
APPLICATION SPEC 取付適用規格  
WEIGHT



NAME 名称  
HDMI TYPE C RECEPTACLE CONNECTOR

SIZE A3 CAGE CODE 00779 DRAWING NO 番号 G-2013978 RESTRICTED TO

CUSTOMER DRAWING

SCALE 尺度 5:1 SHEET 3 OF 5 REV B1

THIS DRAWING IS UNPUBLISHED. RELEASED FOR PUBLICATION  
 © COPYRIGHT - By - ALL RIGHTS RESERVED.

LOC	DIST	REVISIONS		
J		变更	DATE	DWN
		DESCRIPTION		APVD
		SEE SHEET 1	-	-

2013978-1;AS SHOWN

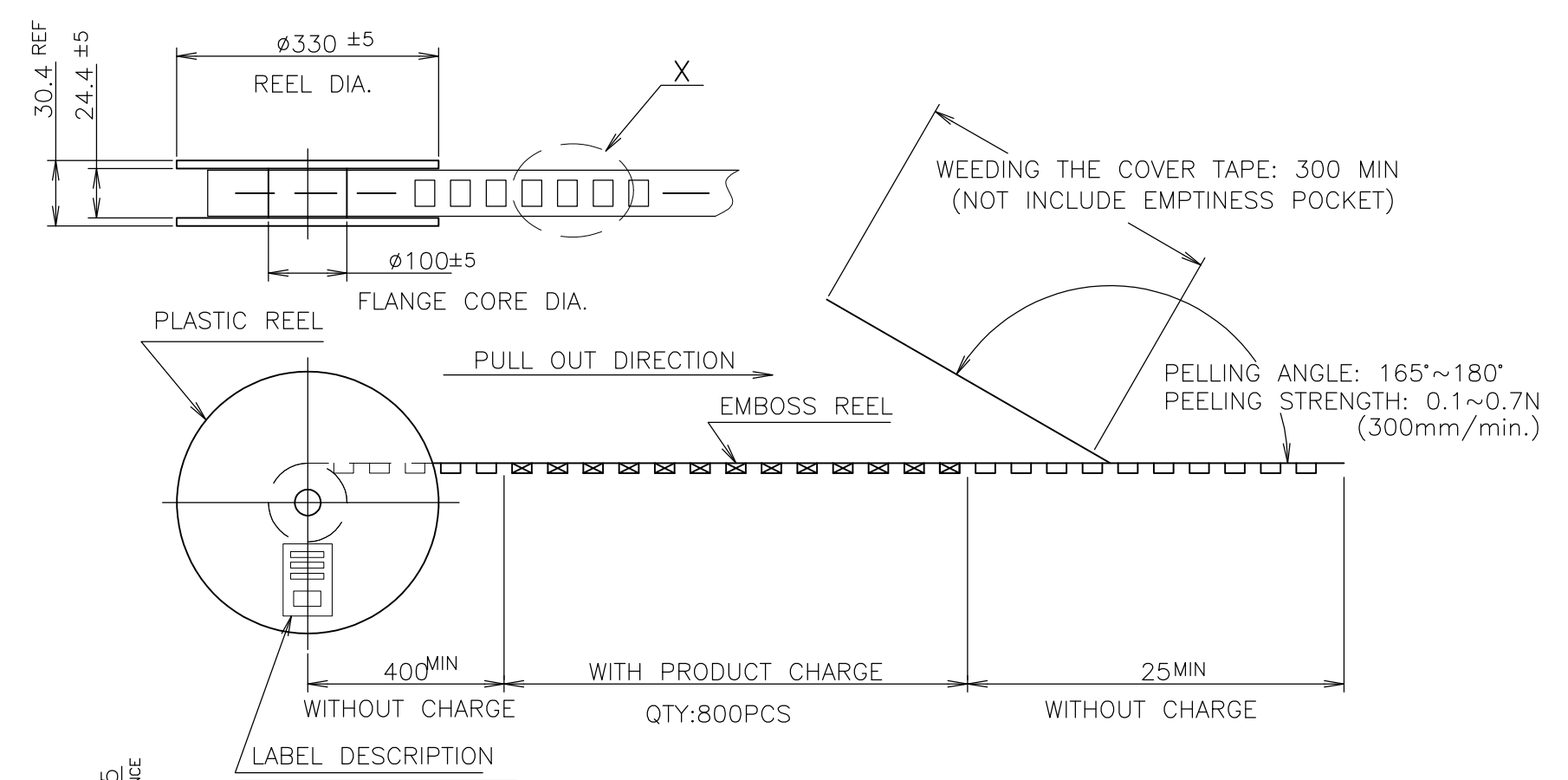

LABEL DESCRIPTION  
 TYCO P/N:  
 QTY:  
 D/C:  
 MADE IN CHINA

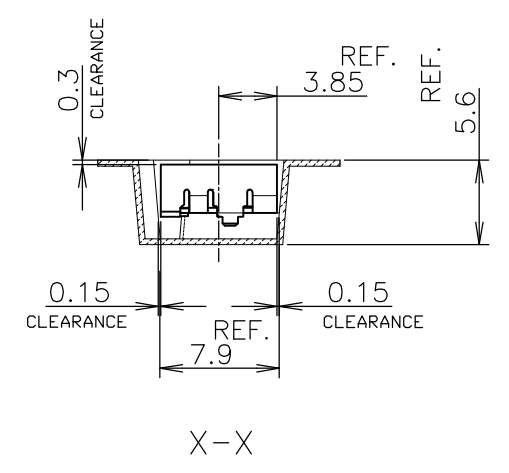
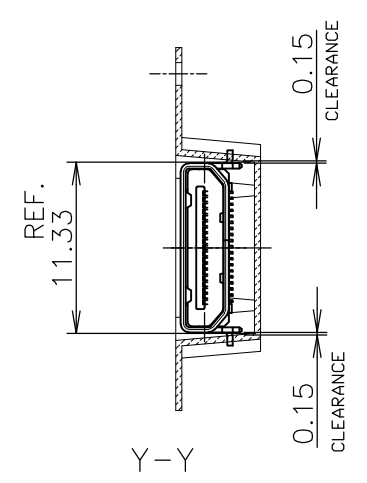
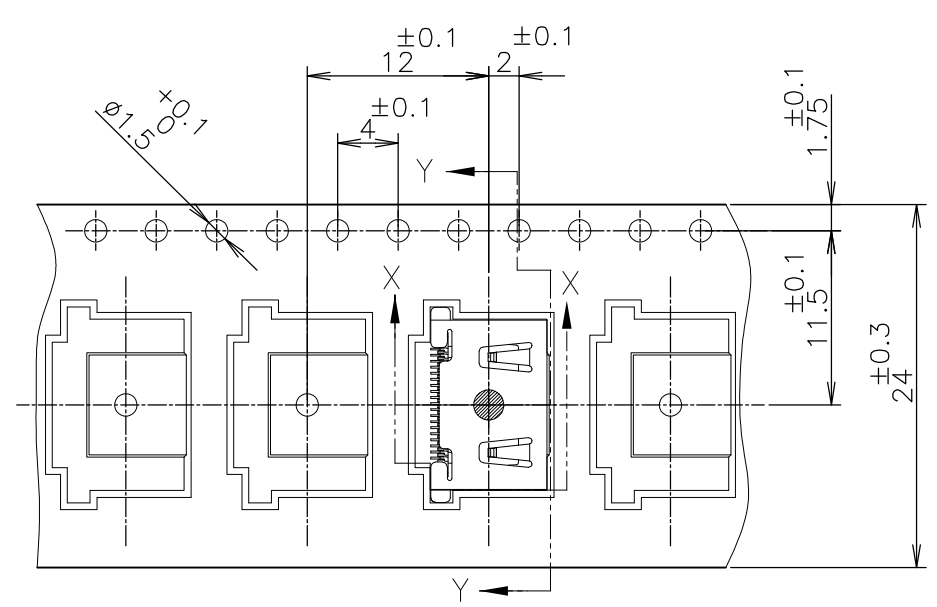

THIS DRAWING IS A CONTROLLED DOCUMENT.		DWN	<b>STE</b> TE Connectivity	
DIMENSIONS: 单位: 耗 mm		CHK		
TOLERANCES UNLESS OTHERWISE SPECIFIED: 一般公差		APVD	NAME 名称	
0 PLC ±		PRODUCT SPEC 製品規格	HDMI TYPE C RECEPTACLE CONNECTOR	
1 PLC ±		APPLICATION SPEC 取付適用規格	SIZE	CAGE CODE
2 PLC ±		MATERIAL 材料	A3	00779
3 PLC ±			DRAWING NO 番号	G-2013978
4 PLC ±		WEIGHT	RESTRICTED TO	
ANGLES ±		CUSTOMER DRAWING		SCALE 尺度 5:1
FINISH 仕上		SHEET 4 OF 5		REV B1

THIS DRAWING IS UNPUBLISHED. RELEASED FOR PUBLICATION  
 © COPYRIGHT - By - ALL RIGHTS RESERVED.

LOC	DIST	REVISIONS		
J		P	LTR	DESCRIPTION
		-		SEE SHEET 1
				DATE
				DWN
				APVD

2013978-2;AS SHOWN

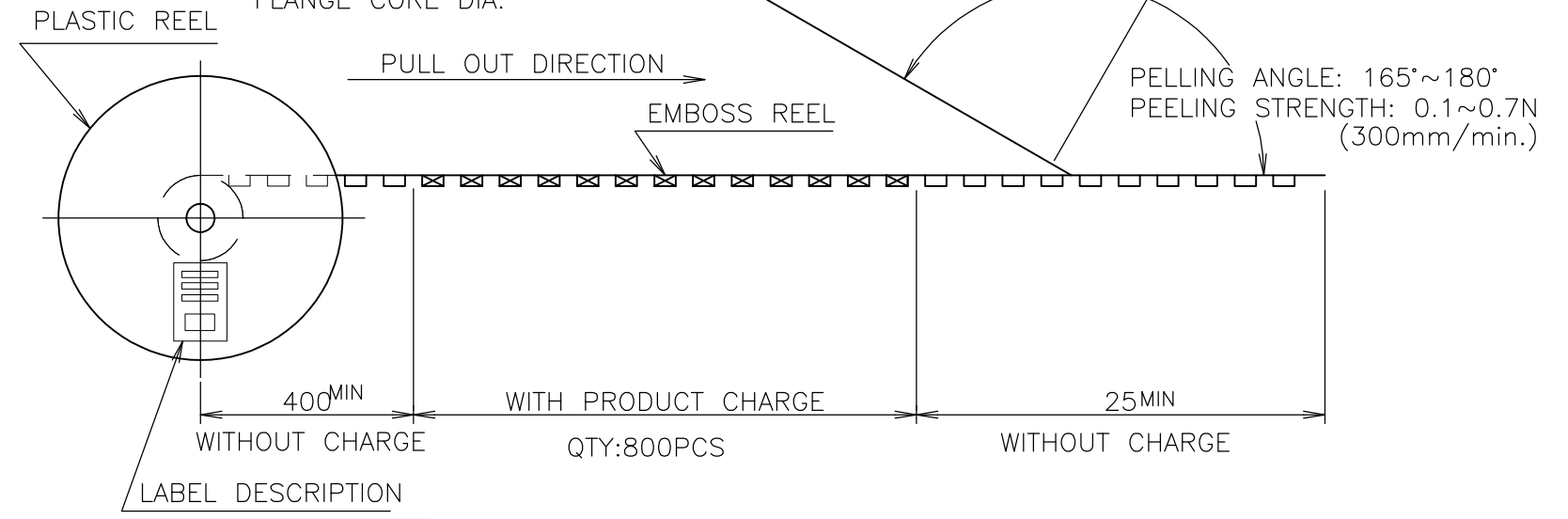
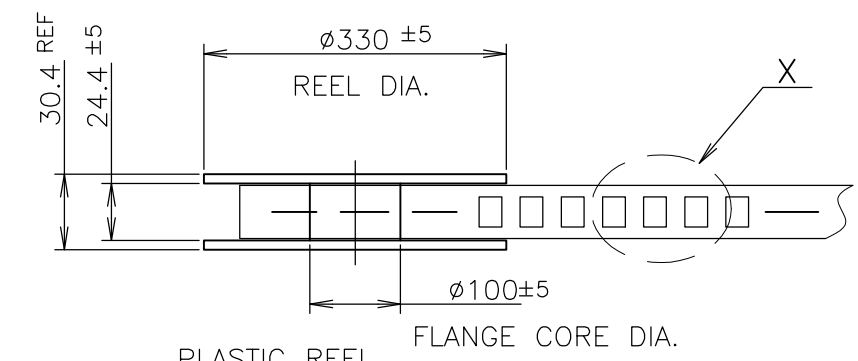
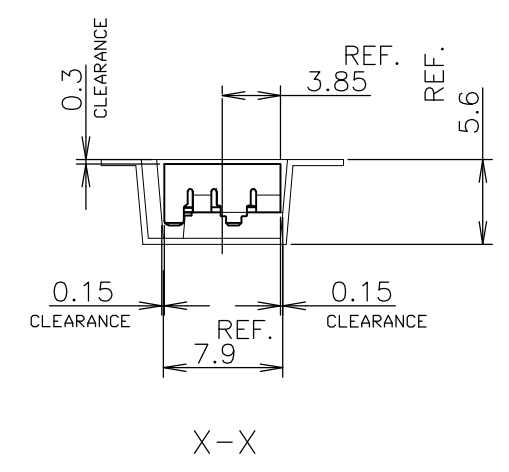
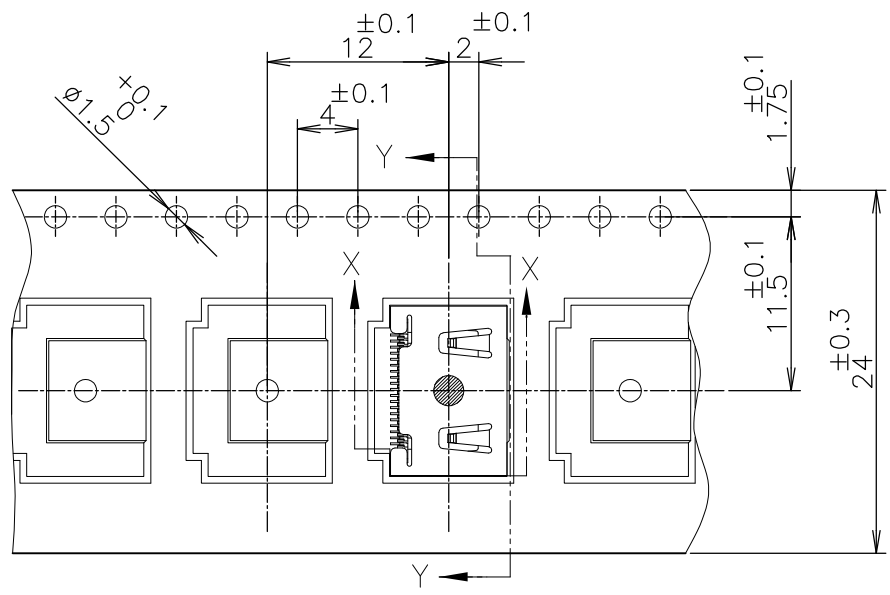

LABEL DESCRIPTION  
 TYCO P/N:  
 QTY:  
 D/C:  
 MADE IN CHINA

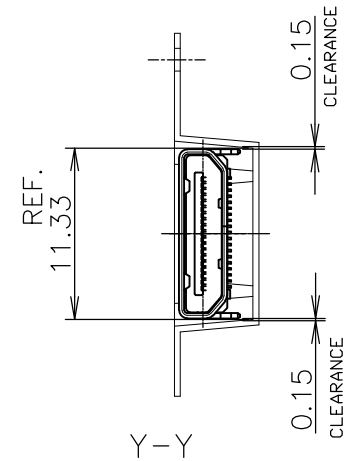

THIS DRAWING IS A CONTROLLED DOCUMENT.		DWN	<b>STE</b> TE Connectivity	
DIMENSIONS: 单位: 耗 mm		CHK		
TOLERANCES UNLESS OTHERWISE SPECIFIED: 一般公差		APVD	NAME 名称	
0 PLC ±		PRODUCT SPEC 製品規格	HDMI TYPE C RECEPTACLE CONNECTOR	
1 PLC ±		APPLICATION SPEC 取付適用規格	SIZE	CAGE CODE
2 PLC ±		WEIGHT	A3	00779
3 PLC ±		CUSTOMER DRAWING	DRAWING NO 番号	
4 PLC ±			G-2013978	
ANGLES ±			RESTRICTED TO	
FINISH 仕上			SCALE 尺度	5:1
			SHEET	5 OF 5
			REV	B1

单击下面可查看定价，库存，交付和生命周期等信息

[>>TE Connectivity\(泰科\)](#)