

PCA-116 Series Gage Heads



- Economy gage head
- AC operation
- 0.0001 inch [2.5 micron] repeatability
- Stroke ranges up to ± 0.30 inch [7.6mm]
- Replaceable hardened tool steel contact tip
- Compatible with all our signal conditioners

DESCRIPTION

The **PCA-116 Series** gage heads were developed to serve less demanding applications, where the balance between price and performance is paramount. Incorporating a standard LVDT (Linear Variable Differential Transformer), low friction nylon sleeve bearings and an externally spring loaded shaft, the PCA-116 affords the most cost effective gaging solution available. Other features include industry standard outer diameter for easy installation, and a replaceable hardened tool steel contact tip using the 4-48 UNF-2 threads.

Measurement Specialties, Inc. (NASDAQ MEAS) offers many other types of sensors and signal conditioners. Data sheets can be downloaded from our web site at: <http://www.meas-spec.com/datasheets.aspx>

MEAS acquired Schaevitz Sensors and the **Schaevitz®** trademark in 2000.

FEATURES

- Stainless steel housing
- Three ranges, ± 0.10 , ± 0.20 and ± 0.30 inch
- Very good reliability
- Low friction Nylon sleeve bearings
- Replacement and other special tips available

APPLICATIONS

- Less demanding applications where cost effective performance is paramount
- Honing machines
- Factory automation in mild environments
- Elevator ride controls

PCA-116 Series Gage Heads

PERFORMANCE SPECIFICATIONS

ELECTRICAL SPECIFICATIONS			
Parameter	PCA-116-100	PCA-116-200	PCA-116-300
Stroke/gaging range	±0.10 [2.5]	±0.20 [5.1]	±0.30 [7.6]
Sensitivity	2.4 mV/V/.001in	1.57 mV/V/.001in	1.2 mV/V/.001in
Output at stroke ends (*)	240 mV/V	314 mV/V	360 mV/V
Phase Shift	-3°	-5°	1.2°
Primary impedance @2.5kHz	660 Ω	970 Ω	960 Ω
Secondary impedance @ 2.5kHz	960 Ω	1010 Ω	1005 Ω
Input voltage	3Vrms		
Input frequency range	50Hz to 10kHz		
Test input frequency	2.5KHz		
Linearity (maximum band)	±0.50% FS (% of Full Scale)		
Repeatability	0.0001 inch [2.5 microns]		
Null voltage (maximum)	1% FSO (% of Full Scale Output)		

MECHANICAL SPECIFICATIONS			
Parameter	PCA-116-100	PCA-116-200	PCA-116-300
Pre-travel	0.10 [2.5]	0.08 [2.0]	0.02 [0.5]
Over-travel (minimum)	0.03 [0.76]	0.09 [2.3]	0.08 [2.0]
Main body length "A"	1.75 [44.4]	2.25 [57.1]	2.75 [69.8]
Plunger length "B" (fully extended)	2.54 [64.5]	3.30 [83.8]	4.10 [104.1]
Rear plunger length "C" (fully compressed)	0.44 [11.2]	0.69 [17.5]	0.88 [22.4]
Spring force	8 ounces [227 grams]		
Weight	1.5oz (43g)	1.7oz (48g)	2.01 oz (57g)

ENVIRONMENTAL SPECIFICATIONS	
Operating temperature	-65°F to +200°F [-55°C to 95°C]
Housing material	AISI 400 Series stainless steel
Lead type/length	Six lead-wires, AWG 28, PTFE insulated, 1 foot [0.3m] long

Notes:

All values are nominal unless otherwise noted

Dimensions are in inch [mm] unless otherwise noted

(*): Unit for output at stroke ends is millivolt per volt of excitation

FS: Full Scale is 2X for ±X stroke

FSO: Full Scale Output is the output at X position for ±X stroke

PCA-116 Series Gage Heads

DIMENSIONS

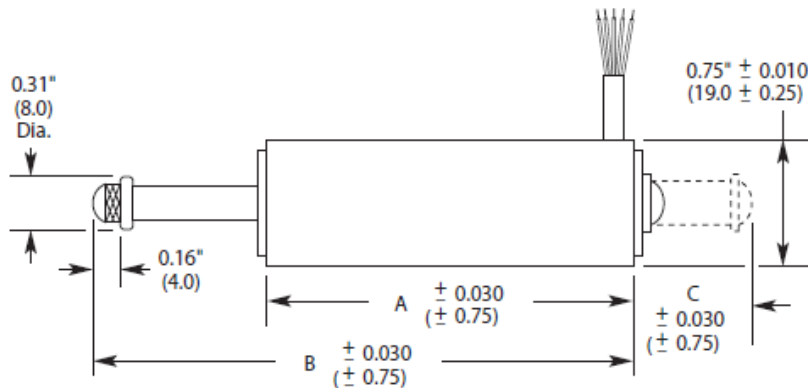

Dimensions are in inches (mm)
(Refer to mechanical specifications for dimensions "A", "B" and "C")

WIRING SCHEMATICS & BLOCK DIAGRAM

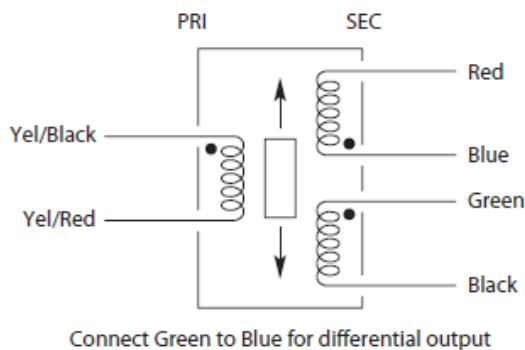

REPLACEMENT/OPTIONAL CONTACT TIPS

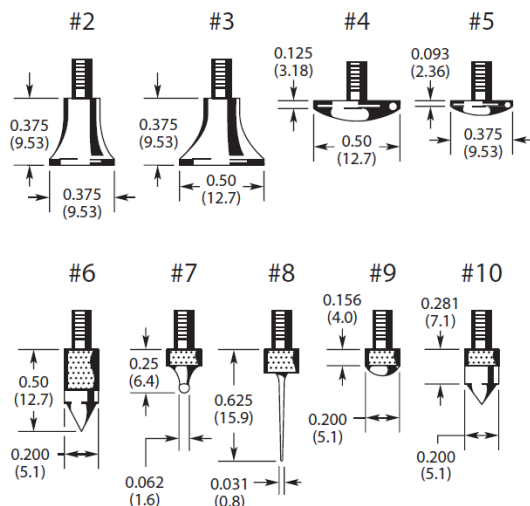

PCA-116 Series Gage Heads

ORDERING INFORMATION

Description	Model	Part Number
±0.10 inch gage head	PCA-116-100	02350531-000
±0.20 inch gage head	PCA-116-200	02350532-000
±0.30 inch gage head	PCA-116-300	02350533-000
Also refer to our " Options and Accessories for Gage Heads " brochure.	Contact Tip 2	67010005-000
	Contact Tip 3	67010006-000
	Contact Tip 4	67010002-000
	Contact Tip 5	67010007-000
	Contact Tip 6	67010008-000
	Contact Tip 7	67010009-000
	Contact Tip 8	67010010-000
	Contact Tip 9	67010001-000
	Contact Tip 10	67010011-000

TECHNICAL CONTACT INFORMATION

NORTH AMERICA	EUROPE	ASIA
Measurement Specialties, Inc. 1000 Lucas Way Hampton, VA 23666 United States Phone: +1-800-745-8008 Fax: +1-757-766-4297 Email: sales@meas-spec.com Web: www.meas-spec.com	MEAS Deutschland GmbH Hauert 13 D-44227 Dortmund Germany Phone: +49-(0)231-9740-0 Fax: +49-(0)231-9740-20 Email: info.de@meas-spec.com Web: www.meas-spec.com	Measurement Specialties China Ltd. No. 26, Langshan Road High-tech Park (North) Nanshan District, Shenzhen 518057 China Phone: +86-755-33305088 Fax: +86-755-33305099 Email: info.cn@meas-spec.com Web: www.meas-spec.com

The information in this sheet has been carefully reviewed and is believed to be accurate; however, no responsibility is assumed for inaccuracies. Furthermore, this information does not convey to the purchaser of such devices any license under the patent rights to the manufacturer. Measurement Specialties, Inc. reserves the right to make changes without further notice to any product herein. Measurement Specialties, Inc. makes no warranty, representation or guarantee regarding the suitability of its product for any particular purpose, nor does Measurement Specialties, Inc. assume any liability arising out of the application or use of any product or circuit and specifically disclaims any and all liability, including without limitation consequential or incidental damages. Typical parameters can and do vary in different applications. All operating parameters must be validated for each customer application by customer's technical experts. Measurement Specialties, Inc. does not convey any license under its patent rights nor the rights of others.

单击下面可查看定价，库存，交付和生命周期等信息

[>>TE Connectivity\(泰科\)](#)