

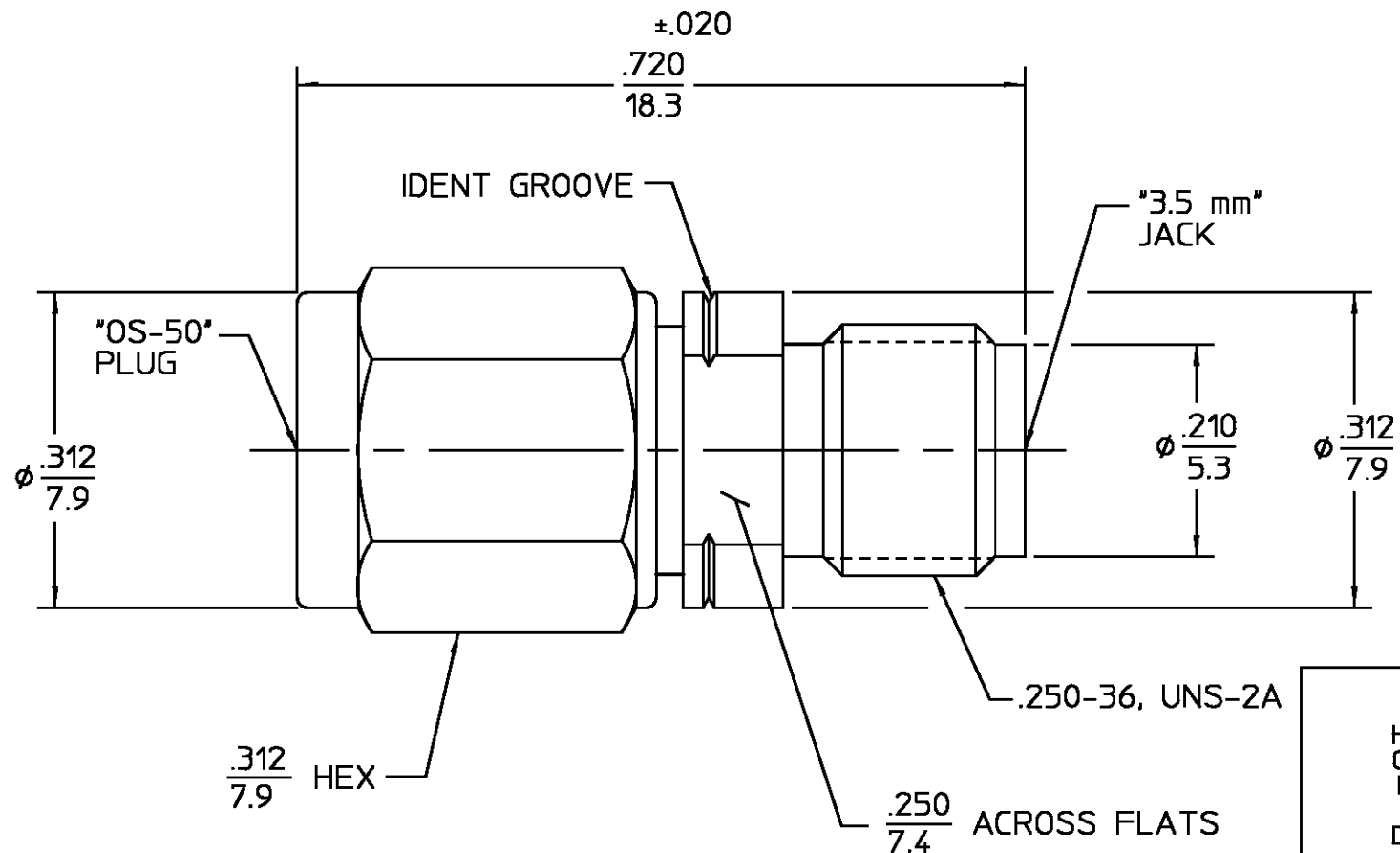

REVISIONS			
REV	DESCRIPTION	DATE	APPROVED
01 ₁	REVISED	KYLE 9-29-97	 10/21/97



HOUSING	STAINLESS STEEL PER ASTM-A484 AND ASTM-A582, TYPE 303	PASSIVATE PER QQ-P-35
COUPLING NUT		
INNER SLEEVE		
DIELECTRIC	PTFE FLUOROCARBON PER ASTM-D-1457	N/A
CENTER CONTACT	BERYLLIUM COPPER PER ASTM-B-196 OR ASTM-B-197, ALLOY C17300, CONDITION H	GOLD PLATE PER MIL-G-45204
RETAINING RING	BERYLLIUM COPPER PER ASTM-B-194, ALLOY C17200, CONDITION H	N/A
GASKET	SILICONE RUBBER PER ZZ-R-765	N/A

COMPONENT	MATERIAL	FINISH
-----------	----------	--------

UNLESS OTHERWISE SPECIFIED DIMENSIONS ARE IN INCHES	DRAWN BY	DAC	DATE	01-05-89	 AMP Incorporated 140 Fourth Avenue Waltham, MA 02451-7599
	CHECKED BY	DAC	DATE	01-05-89	
	APPD BY	S.M	DATE	01-05-89	

These drawings and specifications are the property of M/A COM Interconnect Div. and shall not be reproduced or copied or used in whole or in part as the basis for the manufacture or sale of item(s) without written permission.	USE ASSY PROCEDURE	TITLE		
	NO. A.P. <u>N/A</u>	'OS-50' PLUG TO '3.5 mm' JACK ADAPTER		
		SIZE	CODE IDENT NO.	REV
	B	26805	8582-2352-02	01 ₁
	SCALE	6:1		SHEET 1 OF 1

NOTES:
1. CAPTURED CENTER CONTACT

.XXX = in
XX.X = mm (REF)

CUSTOMER DRAWING

AMP PART # 1063398-1
SHEET 1 OF 1 REV A

单击下面可查看定价，库存，交付和生命周期等信息

[>>TE Connectivity\(泰科\)](#)