

THIS DRAWING IS UNPUBLISHED. RELEASED FOR PUBLICATION  
 © COPYRIGHT - By - ALL RIGHTS RESERVED.

REVISIONS				
P	LTR	DESCRIPTION	DATE	APVD
L		REVISED PER ECO-15-012503	02MAR2016	NK JO

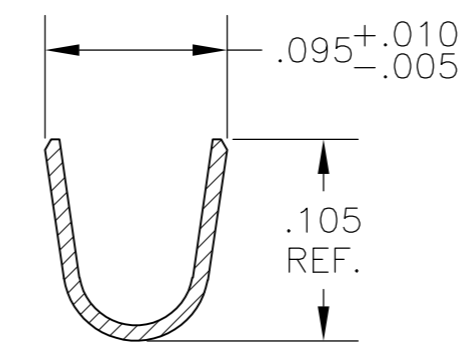
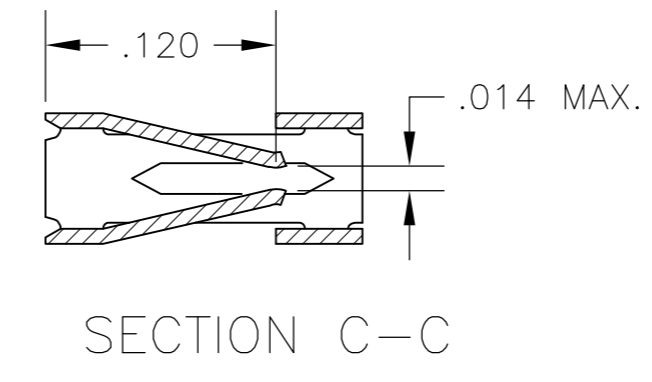
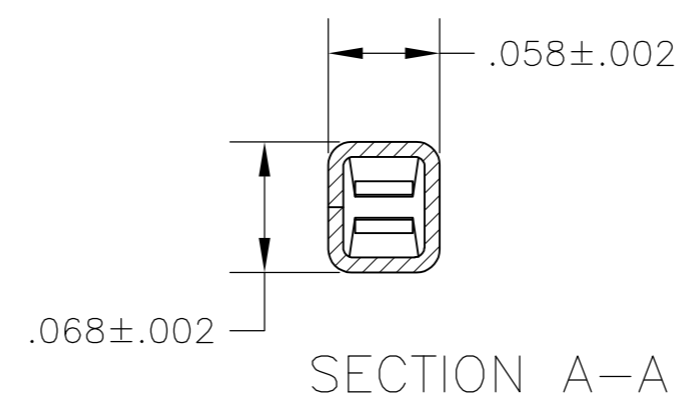
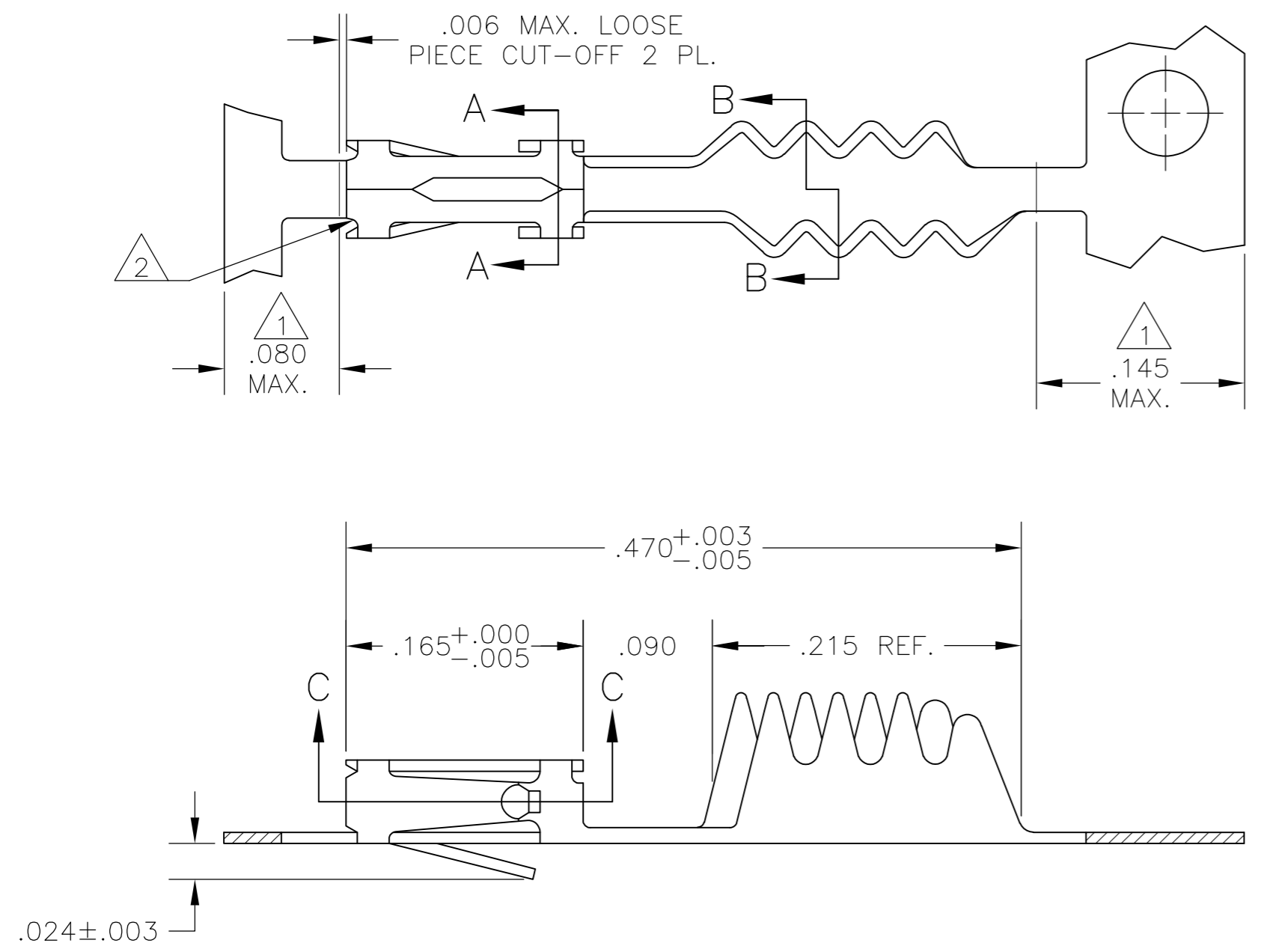

INSULATION RANGE .055 MAX.

- 1 GOLD PLATING IS NOT REQUIRED IN THIS AREA.
- 2 CUT-OUTS ON THE BOX ARE AT MANUFACTURERS OPTION.
- 3 THIS TERMINAL IS REELED FOR THE STANDARD APPLICATOR.
- 4 THIS TERMINAL IS REELED FOR THE MINI APPLICATOR.
- 5 .000030 GOLD OVER .000050 NICKEL.
- 6 .000030 GOLD ON THE CONTACT AREA, GOLD FLASH ON THE REMAINDER ALL OVER .000050 NICKEL.
- 7 PREPLATED:(HALT).000078-.000158 BRIGHT TIN
- 8 POINT OF MEASUREMENT FOR PLATING THICKNESS (INSIDE BEAMS).
- 9 OBSOLETE PART NO.

87107-3	4	7	102348-3	87107-6
87107-8	4	6	102348-2	87107-5
87107-8	3	6	102348-2	
9 87107-7	4	5	102348-1	9 87107-2
9 87107-7	3	5	102348-1	
IN-PROCESS PART NUMBER	REMARKS	FINISH	LOOSE PIECE PART NUMBER	PART NUMBER

THIS DRAWING IS A CONTROLLED DOCUMENT.

DWN	L D RINGLY	12-10-85
CHK	J L GESFORD	12-16-85
APVD	J L GESFORD	12-16-85
PRODUCT SPEC	108-25,020	
APPLICATION SPEC	114-25,003	
WEIGHT	-	
CUSTOMER DRAWING	SCALE	10:1

**TE** TE Connectivity

CONTACT, MOD IV, RECEPTACLE, CRIMP SNAP-IN

SIZE	A2	CAGE CODE	00779	DRAWING NO	C=87107	RESTRICTED TO	-
SHEET	1	OF 1	REV	L			

单击下面可查看定价，库存，交付和生命周期等信息

[>>TE Connectivity\(泰科\)](#)