

THIS DRAWING IS UNPUBLISHED. RELEASED FOR PUBLICATION  
 © COPYRIGHT - By - ALL RIGHTS RESERVED.

REVISIONS				
P	LTR	DESCRIPTION	DATE	APVD
J2		REVISED PER ECO-16-004223	20JUL2016	NK MZ

- 1 WIRE RANGE 18-16 AWG.
- 2 COLOR CODED BLUE IN SPRING DIMPLE AREA.
- 3 0.76µm [.000030] MIN GOLD PER MIL-G-45204 ON MATING END FOR A LENGTH OF 5.08 [.200] MIN WITH A UNIFORM GRADIENT TO 0.25µm [.000010] MIN GOLD PER MIL-G-45204 ON INSULATION SUPPORT BARREL OVER 0.76 NICKEL PER QQ-N-290.

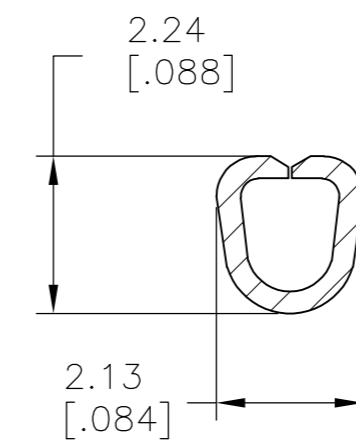
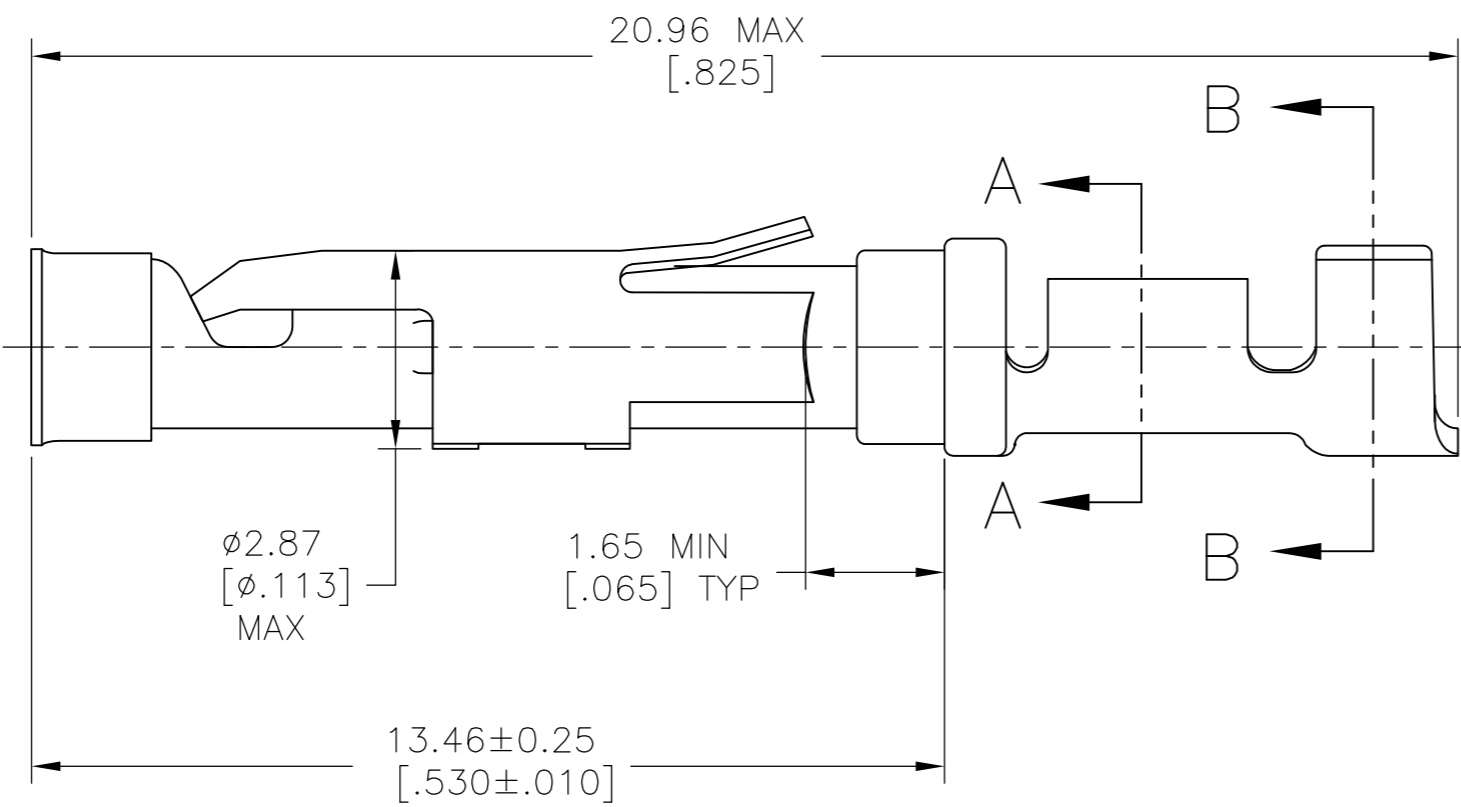
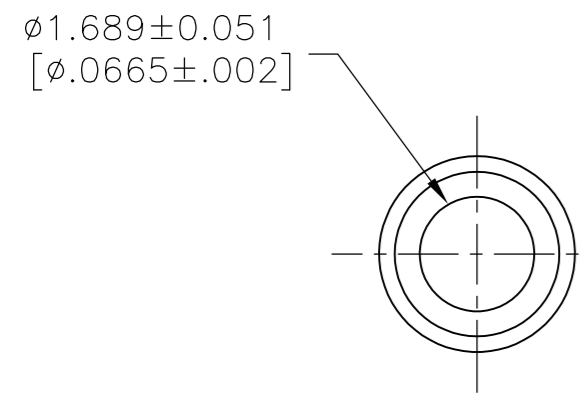
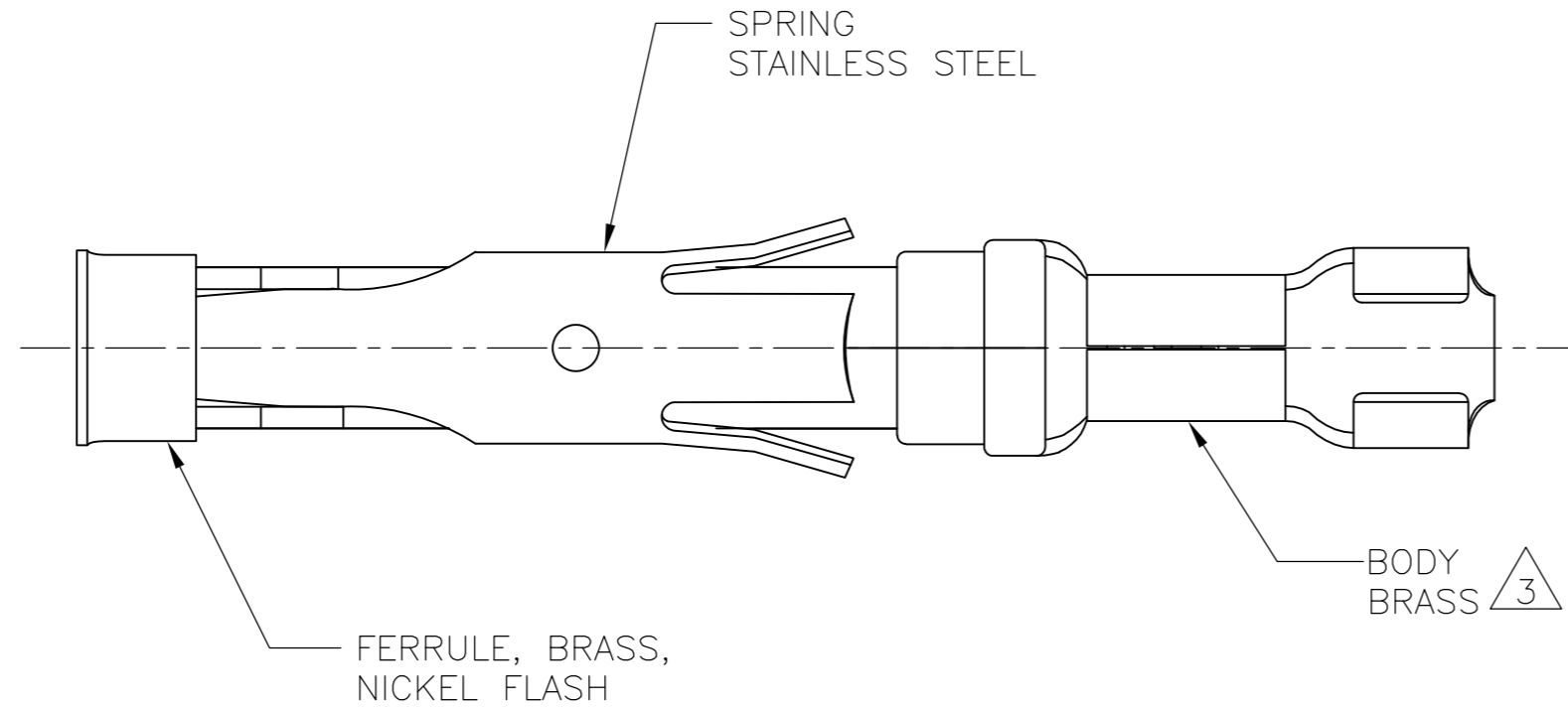

SECTION A-A

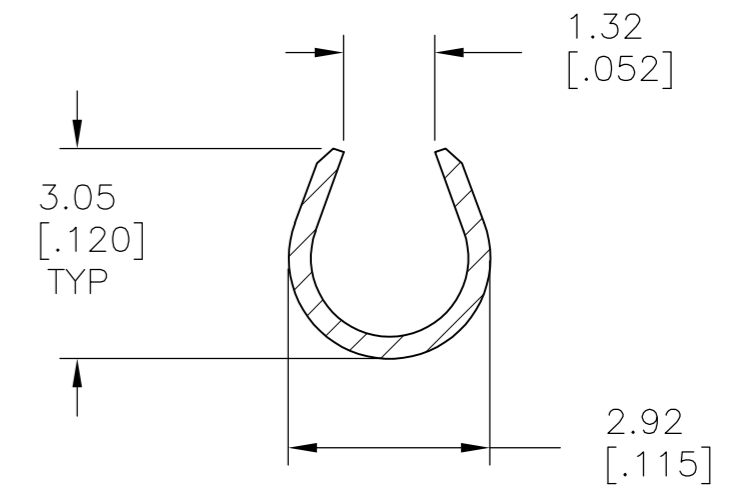

SECTION B-B

OBSOLETE	SMALL PACK	<del>66181-3</del>
	STANDARD	66181-1
	PACKAGING TYPE	PART NO

THIS DRAWING IS A CONTROLLED DOCUMENT.		DWN	R.SHIREY	7-29-91		TE Connectivity				
DIMENSIONS: mm [INCHES]		CHK	R.STONE	9-19-91		NAME				
TOLERANCES UNLESS OTHERWISE SPECIFIED:		APVD	J.WESTMAN	9-20-91		SOCKET ASSEMBLY, LOOSE PIECE, TYPE III+				
0 PLC ± - 1 PLC ± - 2 PLC ± 0.13[.005] 3 PLC ± - 4 PLC ± - ANGLES ± -		PRODUCT SPEC				SIZE	CAGE CODE	DRAWING NO	RESTRICTED TO	
MATERIAL SEE CALLOUTS		FINISH	SEE CALLOUTS		WEIGHT	A2	00779	C=66181	—	
CUSTOMER DRAWING					SCALE	8:1	SHEET	1 OF 1	REV	J2

单击下面可查看定价，库存，交付和生命周期等信息

[>>TE Connectivity\(泰科\)](#)