

THIS DRAWING IS UNPUBLISHED. RELEASED FOR PUBLICATION

© COPYRIGHT BY TYCO ELECTRONICS CORPORATION. ALL RIGHTS RESERVED.

LOC DS DIST

REVISIONS

P	LTR	DESCRIPTION	DATE	DWN	APVD
E1	REVISED	ECR-06-002095	20,JAN'08	YH	JK
E2	REVISED	ECR-06-002993	07,FEB'08	YH	JK
E3	REVISED	ECR-06-004324	13,SEP'08	BS	JK

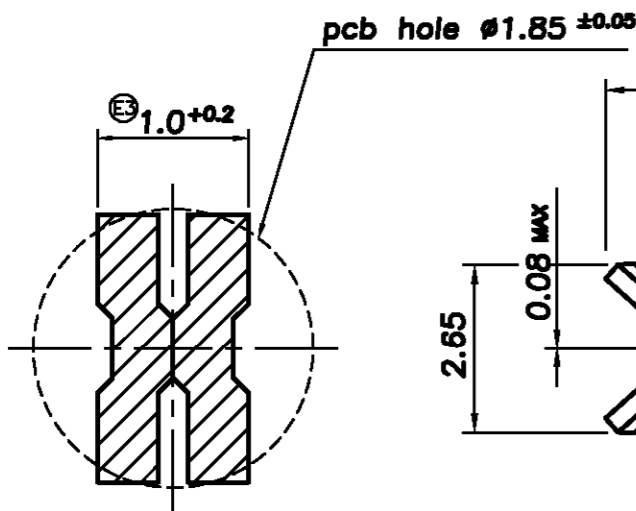

SECTION "A-A" SCALE 20/1

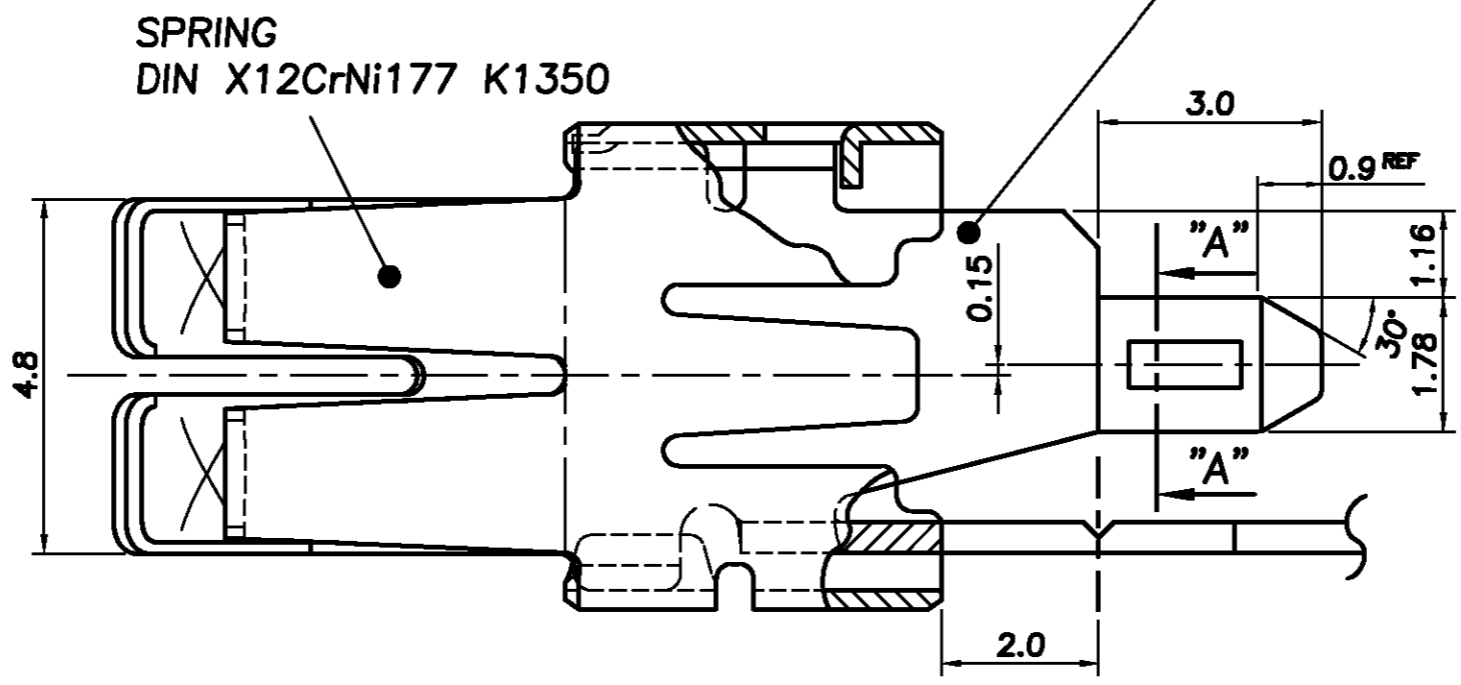
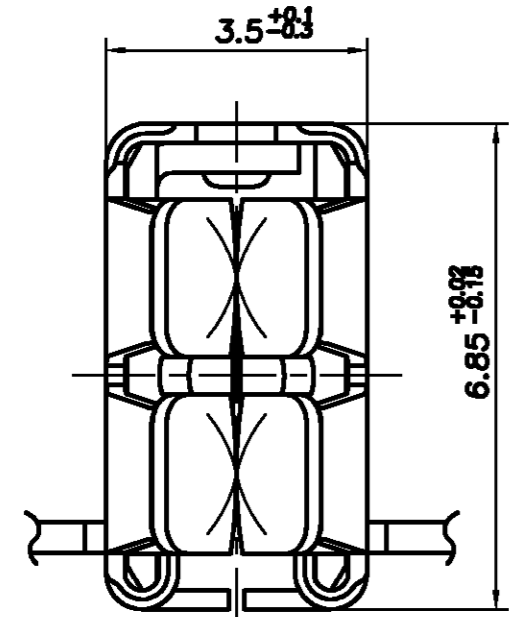
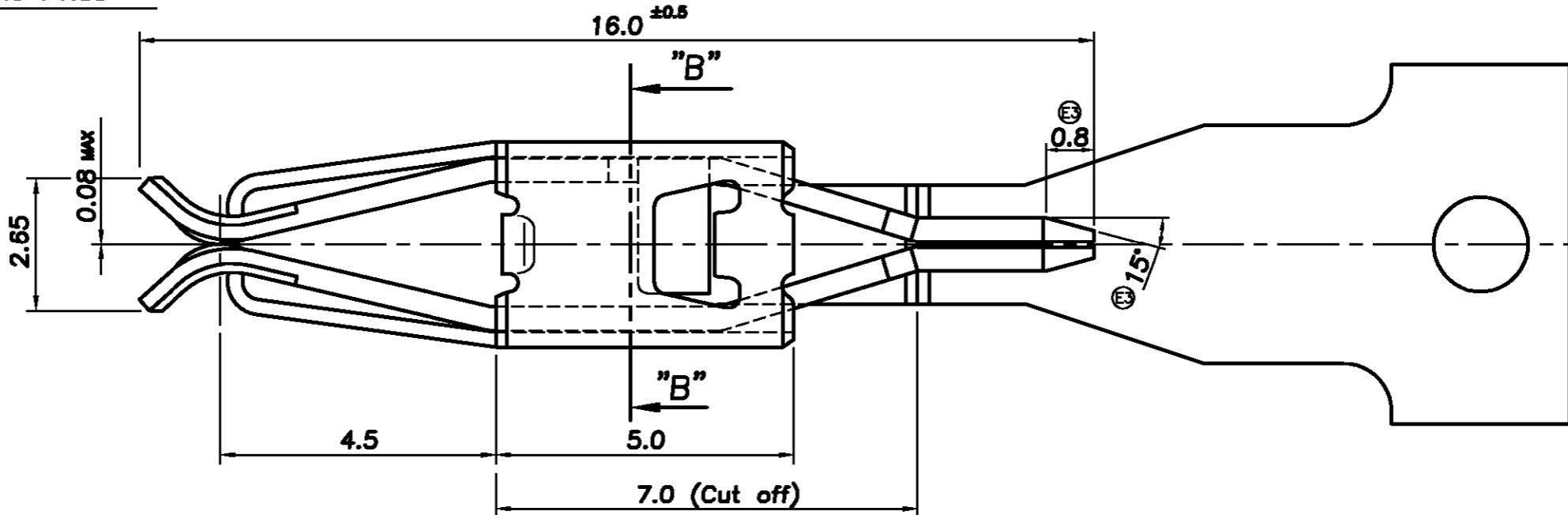

SPRING
DIN X12CrNi177 K1350

BODY

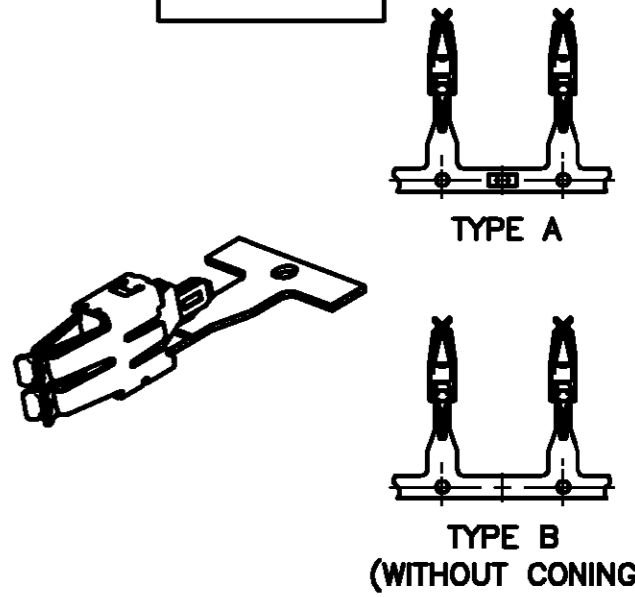

	TOP OF REEL	PART NUMBER	REEL TYPE	REMARK
'Y'	2-	368028 -1	TYPE B	1POST
'X'	1-	368028 -2	TYPE A	
'Y'	1-	368028 -1		
'Z'		368028 -1		

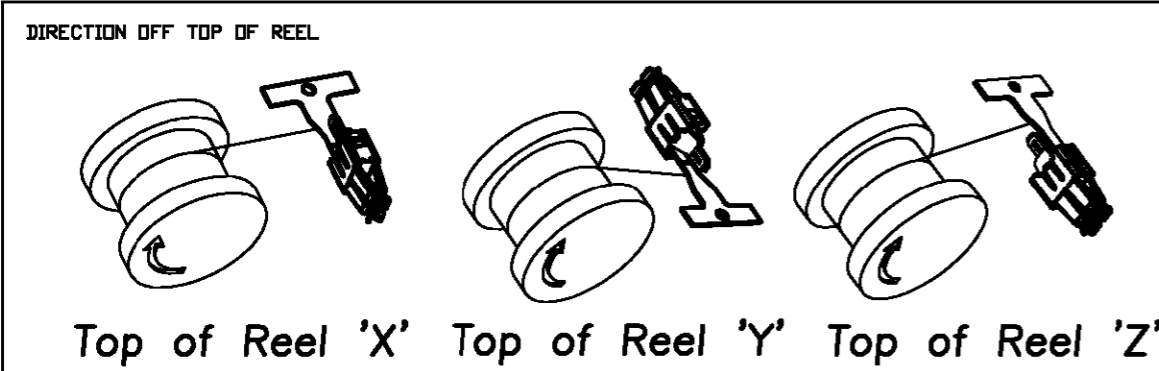

THIS DRAWING IS A CONTROLLED DOCUMENT FOR TYCO ELECTRONICS CORPORATION. IT IS SUBJECT TO CHANGE AND THE CONTROLLING ENGINEERING ORGANIZATION SHOULD BE CONTACTED FOR THE LATEST REVISION.

DIMENSIONS: MM	TOLERANCES UNLESS OTHERWISE SPECIFIED: 0 <XX<10 ± 0.2 10 <XX<30 ± 0.25 30 <XX<100 ± 0.3 ANGLES ± 3°
3rd ANGLE PROJECTION	
MATERIAL: CuNiSi Alloy 0.4Thk.	FINISH: PRE-TINNED

DWN: BS.YOO	CHK: YM.CHOI
APVD: JK.SONG	PRODUCT SPEC: 108-61041
APPLICATION SPEC:	WEIGHT: NET. 1.02gf

tyco AMP KOREA, kyungsan, korea
Electronics

NAME: STANDARD POWER TIMER CONTACT FOR P.C.B - W/O LATCH

SIZE: A3	CAGE CODE: 00779	DRAWING NO: 368028	RESTRICTED TO:
CUSTOMER DRAWING			SCALE 10/1 SHEET 1 OF 2 REV E3

LOC	DIST	REVISIONS					
DS		P	LTR	DESCRIPTION	DATE	DWN	APVD
				SEE SHEET 1 OF 2			

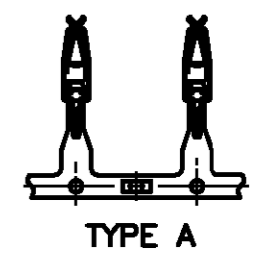
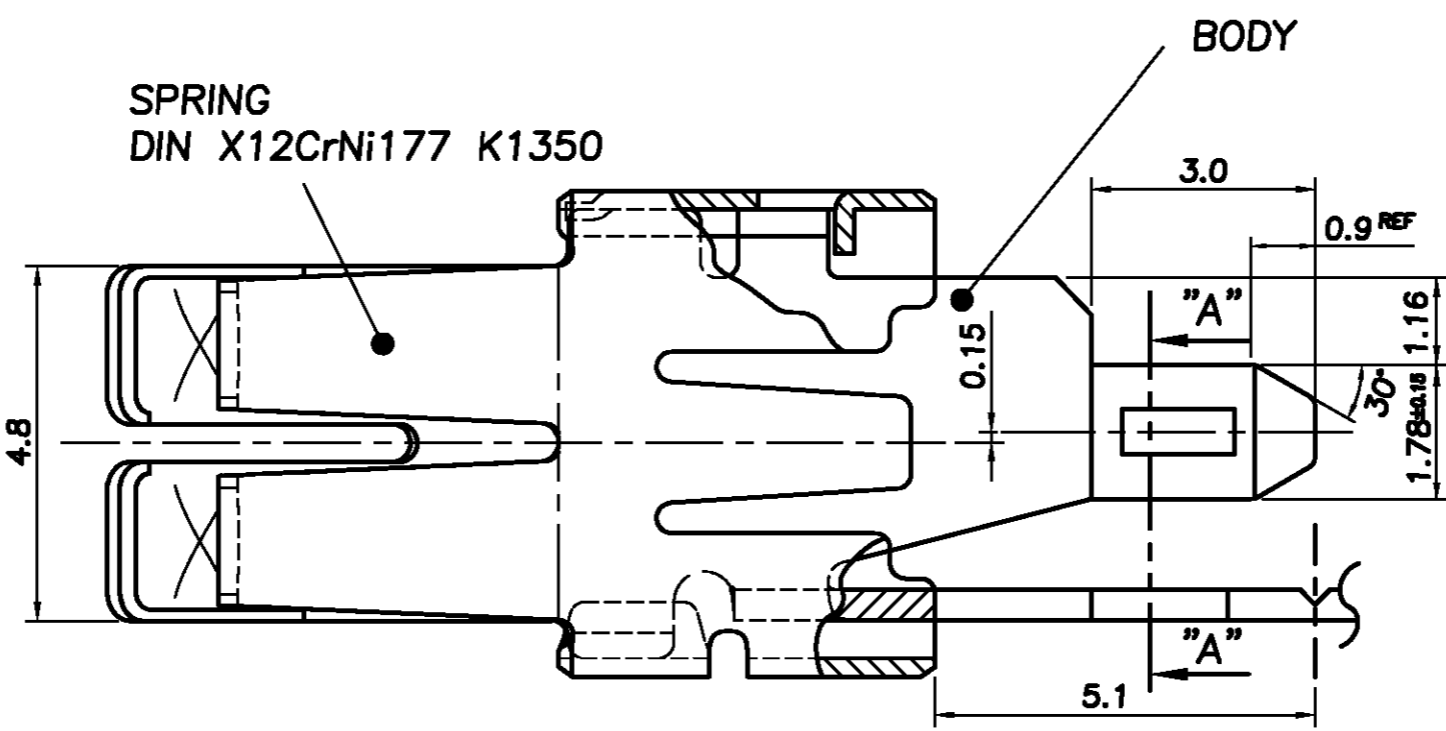
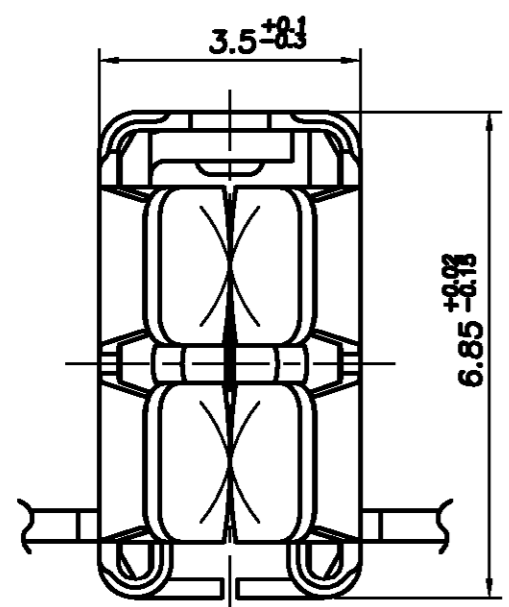
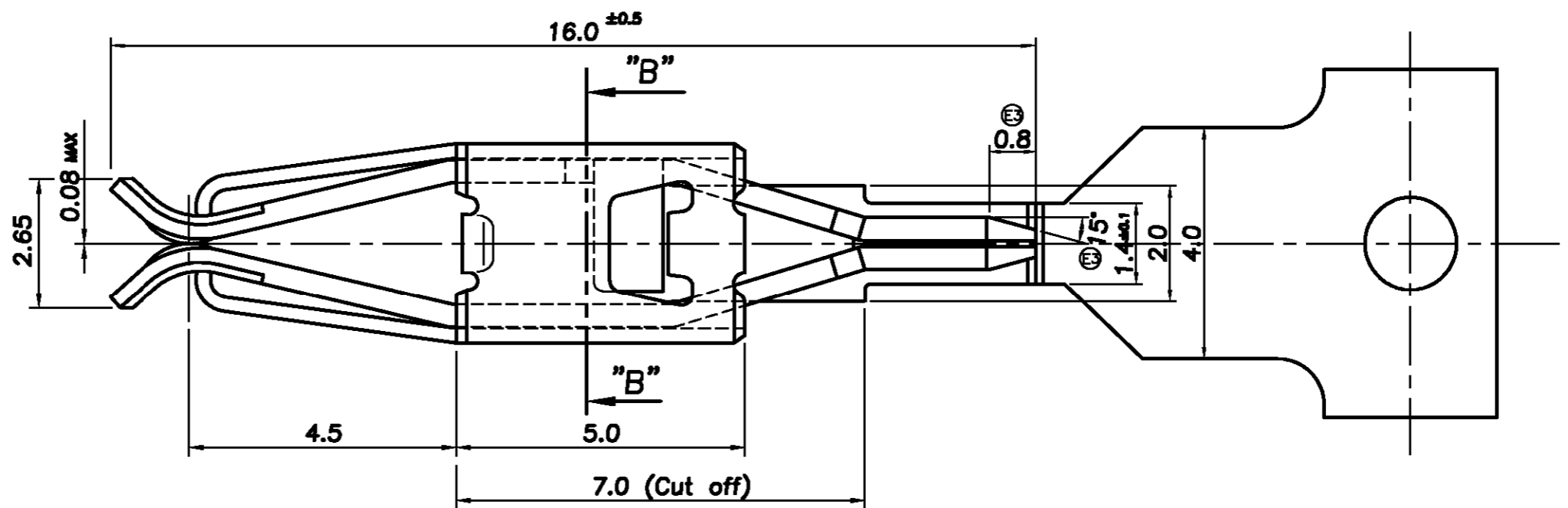
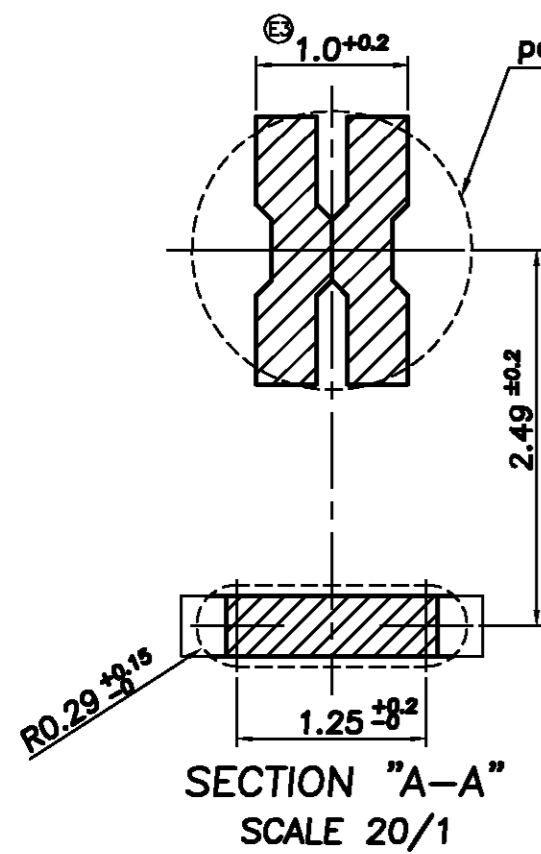

'Y'	1- 368028 -3	TYPE A	2 POST
'X'	0- 368028 -3		
TOP OF REEL	PART NUMBER	REEL TYPE	REMARK

DIRECTION OFF TOP OF REEL

SEE SHEET 1 OF 2

DIMENSIONS: MM		TOLERANCES UNLESS OTHERWISE SPECIFIED:	
3rd ANGLE PROJECTION		0 <XX<10 ± 0.2	10 <XX<30 ± 0.25
MATERIAL: CuNiSI Alloy 0.4Thk.		30 <XX<100 ± 0.3	ANGLES ± 3°
FINISH: PRE-TINNED			

DWN	
CHK	
APVD	
PRODUCT SPEC	108-61041
APPLICATION SPEC	
WEIGHT	NET. 1.06gf

tyco Electronics		AMP KOREA, kyungsan, korea	
NAME: STANDARD POWER TIMER CONTACT FOR P.C.B - W/O LATCH			
SIZE	CAGE CODE	DRAWING NO	RESTRICTED TO
A3	00779	3 6 8 0 2 8	
CUSTOMER DRAWING		SCALE 10/1	SHEET 2 OF 2 REV E3

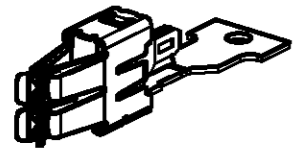

单击下面可查看定价，库存，交付和生命周期等信息

[>>TE Connectivity\(泰科\)](#)