

THIS DRAWING IS UNPUBLISHED. RELEASED FOR PUBLICATION  
 © COPYRIGHT BY TYCO ELECTRONICS CORPORATION. ALL RIGHTS RESERVED.

LOC	DIST	REVISIONS					
AJ	16	P	LTR	DESCRIPTION	DATE	DWN	APVD
		0		REV PER EC-0S14-0496-04	31JAN2005	AF	JGH

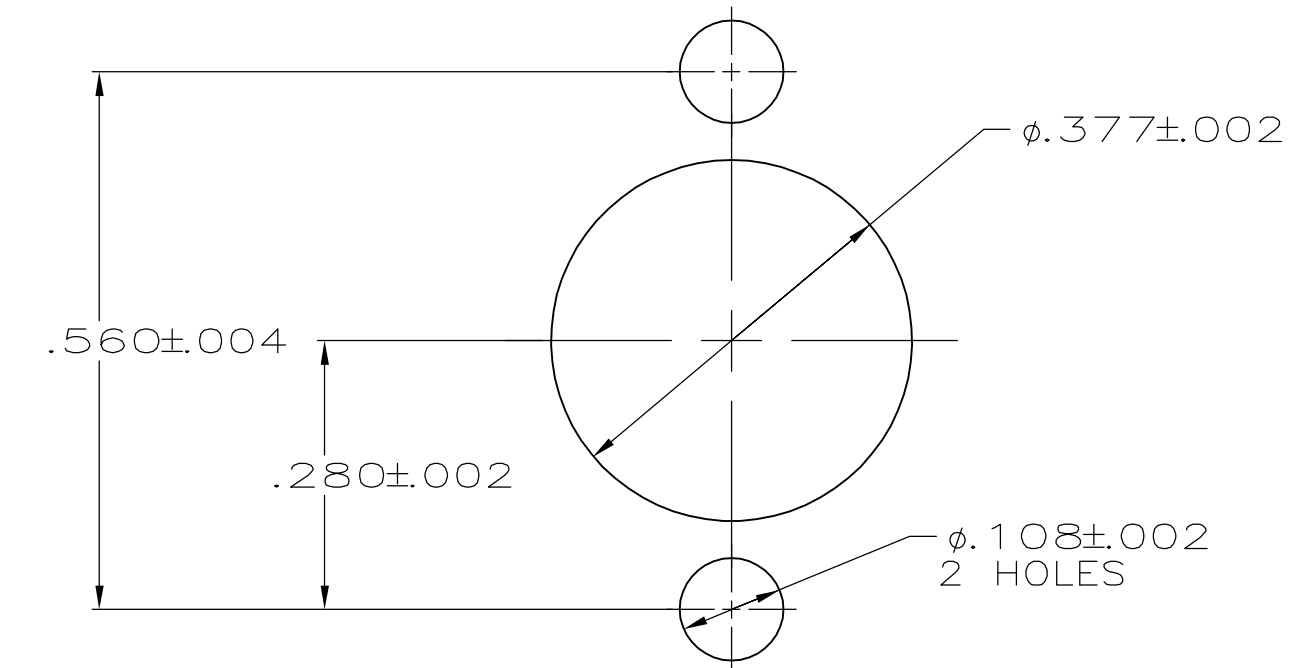
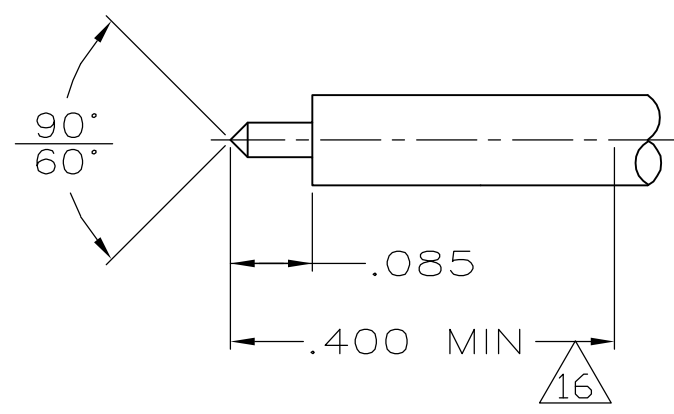
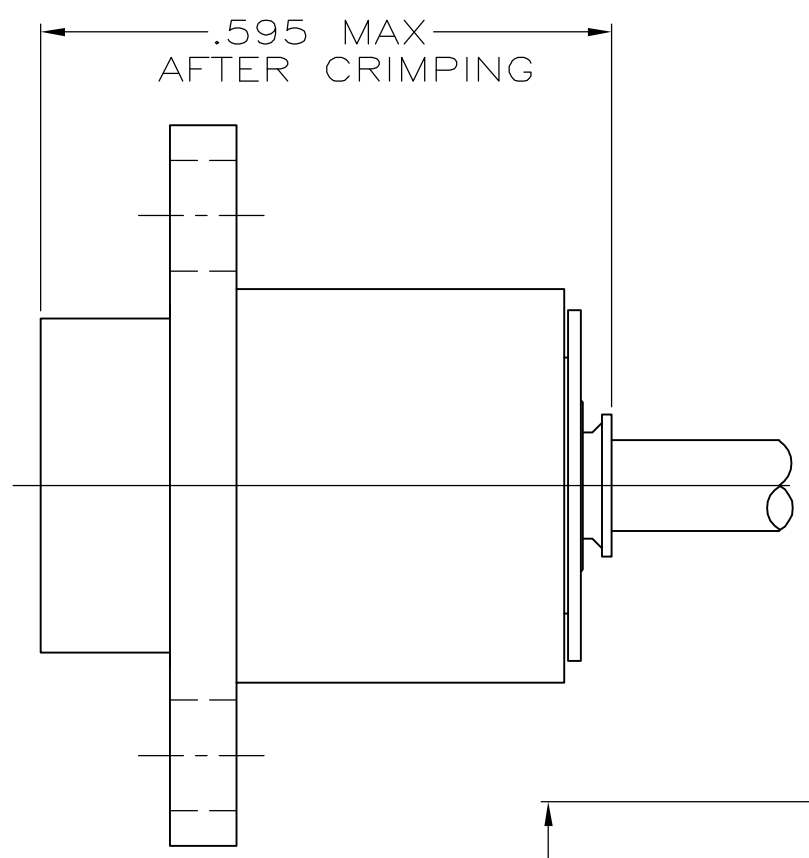
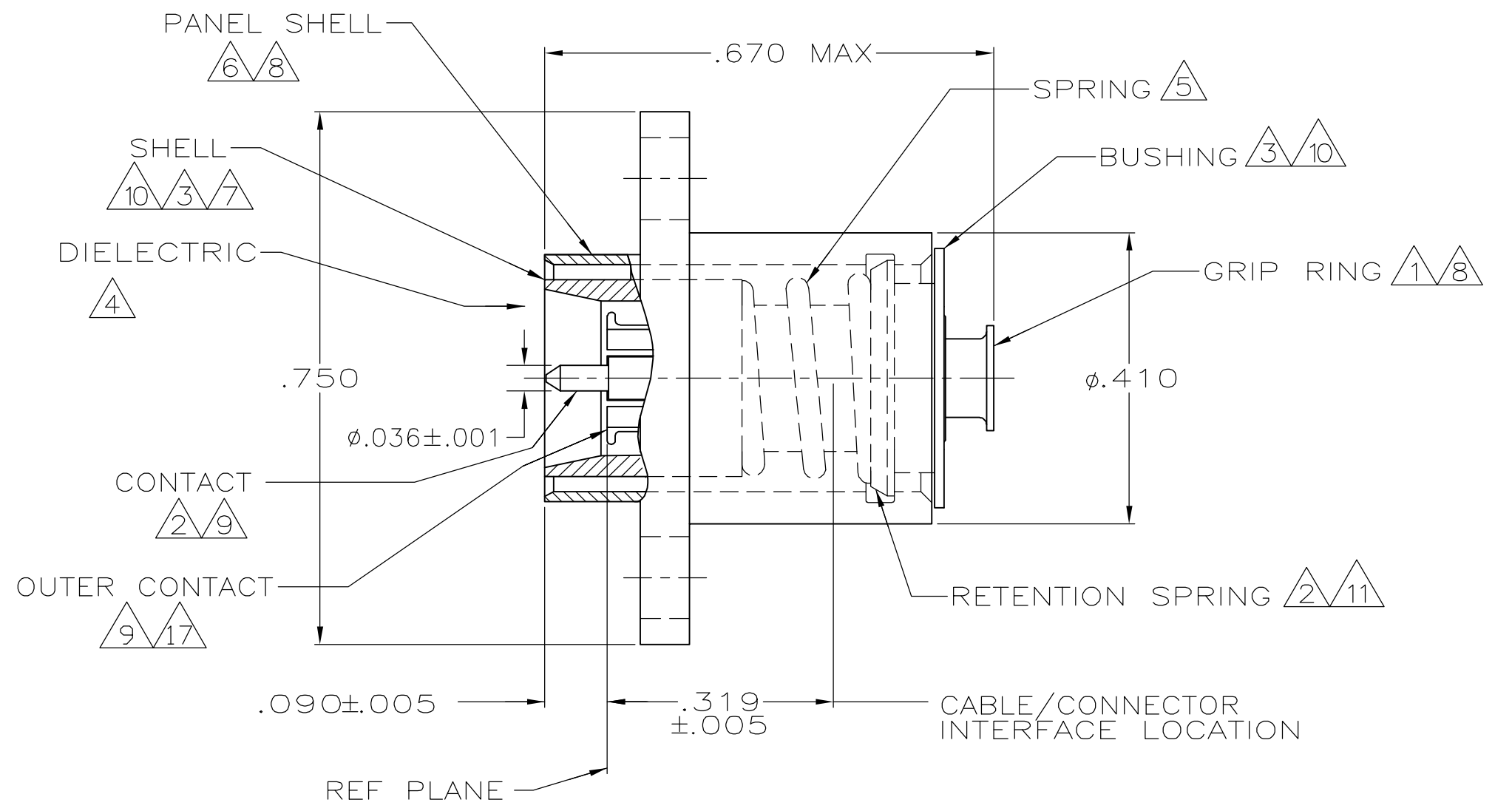

- 1 BRASS PER MIL-C-50
- 2 BERYLLIUM COPPER PER QQ-C-530
- 3 STAINLESS STEEL PER ASTM-A-582
- 4 PTFE PER MIL-P-19468
- 5 STEEL WIRE PER QQ-W-470
- 6 BRASS PER QQ-B-626
- 7 SEALANT
- 8 NICKEL PL PER QQ-N-290
- 9 GOLD PL PER MIL-G-45204
- 10 PASSIVATION PER QQ-P-35
- 11 TIN PL PER ASTM-B-545
- 12. FOR USE WITH: RG-402, .141 SEMI-RIGID CABLE
- 13. USE CRIMPING TOOL: 59980-1
- 14. .190 MAX PANEL THICKNESS
- 15. .060 MAX FLOAT PERMITTED DUE TO INTERNAL SPRING
- 16 STRAIGHT CABLE REQUIRED TO APPLY CONNECTOR
- 17 BOILLAT B05 PER UNS 53800.

RECOMMENDED STRIP LENGTH

RECOMMENDED MOUNTING HOLES

5222200-1  
 PART NUMBER

THIS DRAWING IS A CONTROLLED DOCUMENT.		DWN A. FERNANDEZ-DOCK5 31JAN2005	Tyco Electronics Corporation Harrisburg, PA 17105-3608	
DIMENSIONS: inches		CHK J. HAVENER 31JAN2005	NAME PLUG,PANEL,BMA MOUNT BLIND MATE 3.5mm	
TOLERANCES UNLESS OTHERWISE SPECIFIED: 0 PLC ± - 1 PLC ± - 2 PLC ± - 3 PLC ± .008 4 PLC ± - ANGLES ± - FINISH		APVD J. HAVENER 31JAN2005	PRODUCT SPEC 108-12106	
MATERIAL 1 THRU 10		FINISH 8 THRU 11	SIZE A2	CAGE CODE 00779
		WEIGHT -	DRAWING NO C=5222200	RESTRICTED TO -
		CUSTOMER DRAWING		SCALE 5:1
		SHEET 1 OF 1		REV 0

5222200

单击下面可查看定价，库存，交付和生命周期等信息

[>>TE Connectivity\(泰科\)](#)