

THIS DRAWING IS UNPUBLISHED. RELEASED FOR PUBLICATION 20
 © COPYRIGHT 20 BY - ALL RIGHTS RESERVED.

LOC		DIST		REVISIONS			
P	LTR	DESCRIPTION	DATE	DWN	APVD		
	D	ECR-15-001456	31JAN2015	M.P.	M.G.		
	D1	ECR-15-011013	29JUL2015	M.P.	M.G.		
	D2	REVISED PER ECO-17-001706	10FEB2017	C.A	M.G		

Ø18: DIAMETRO MINIMO DI UN FORO ATTRAVERSO IL QUALE IL CONNETTORE PUO' PASSARE (MINIMUM HOLE DIAMETER THE CONNECTOR CAN PASS THROUGH)

SECTION C-C

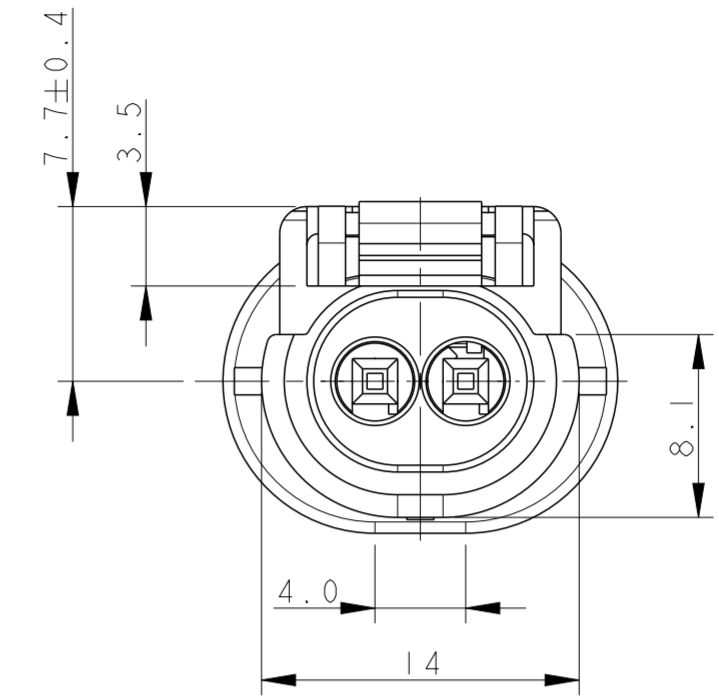
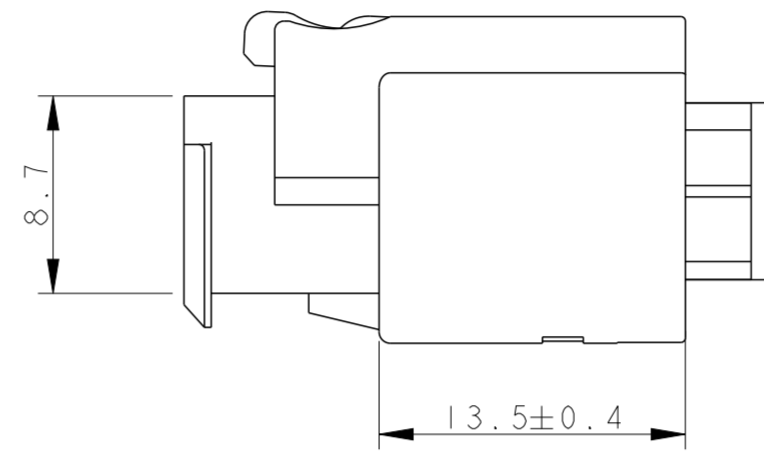
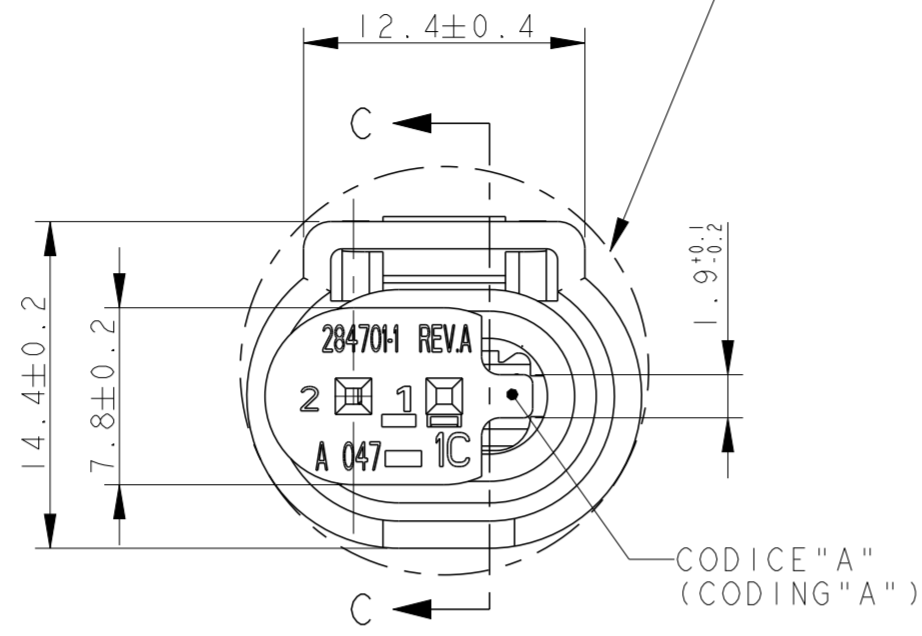
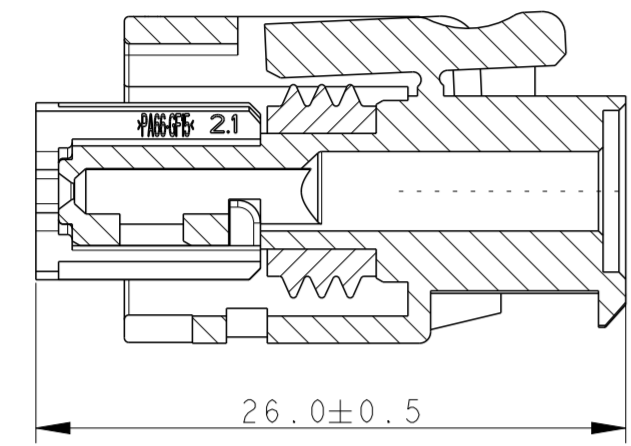

P/N 284703-1 AS SHOWN (CODING A)

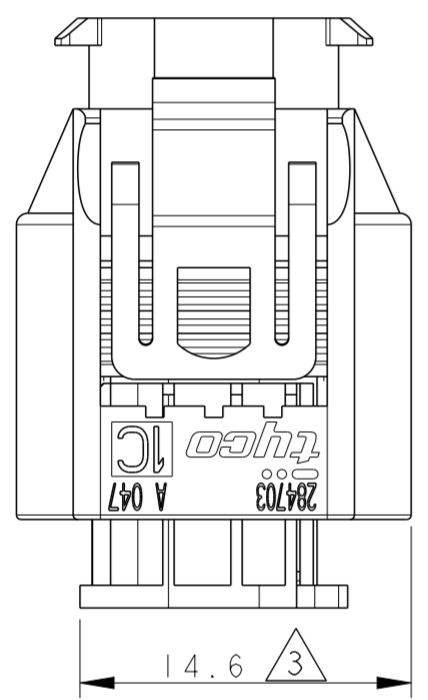

VISTA CON SECONDARY LOCK CHIUSO (VIEW WITH SECONDARY LOCK IN CLOSED POSITION)

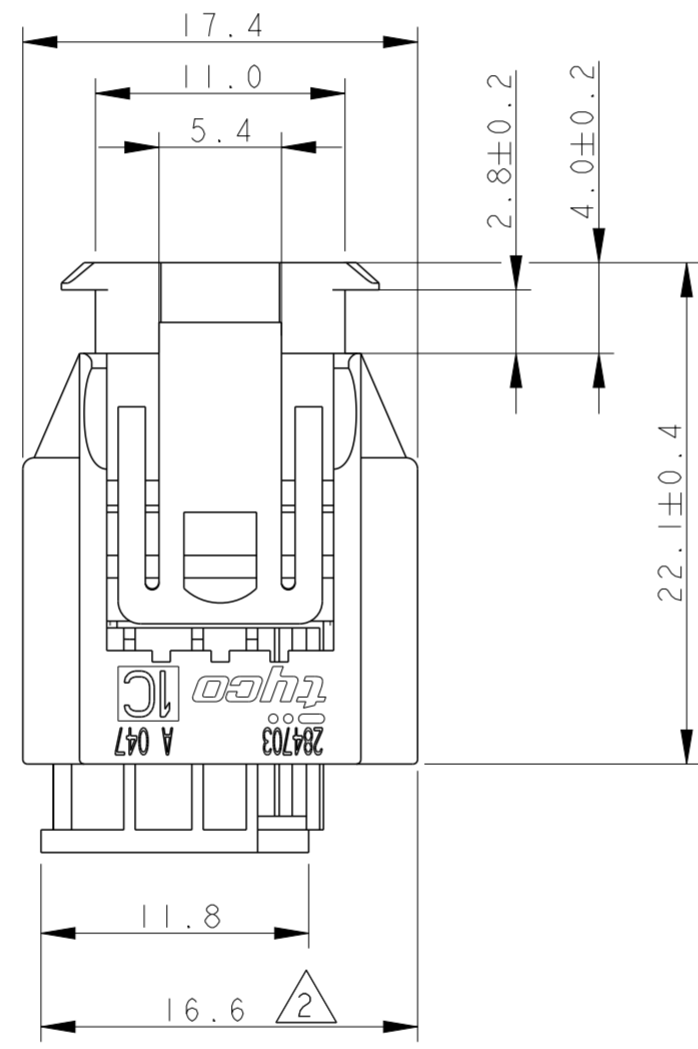

REVISIONE PRODOTTO (PRODUCT REVISION)

- LE CAVITA' SONO ADATTE PER INSERIRE I CONTATTI MQS: P/N 962885-... (0.35-0.5 mmq) E 965906-... (0.75 mmq) CON I RELATIVI GOMMINI PASSACAVO P/NS 967067-1/-2. VEDERE LA SPECIFICA DI APPLICAZIONE 114-18025 PER LA CORRETTA AGGRAFFATURA (CAVITIES ARE SUITABLE FOR MQS SOCKET CONTACTS: P/N 962885-... (0.35-0.5sqmm) AND 965906-... (0.75sqmm) AND RELEVANT SINGLE WIRE SEAL P/NS 967067-1/-2 SEE APPLICATION SPEC. No. 114-18025 FOR CORRECT WIRE CRIMP PARAMETERS)
- STATO DI FORNITURA, SECONDARY LOCK IN POSIZIONE PREASSEMBLATA (SUPPLYING CONDITION, SECONDARY LOCK IN PRE-ASSEMBLED POSITION)
- SECONDARY LOCK IN POSIZIONE CHIUSA (DOPO L'INSERIMENTO DEI CONTATTI IN CAVITA') PER LA CONNESSIONE CON LA CONTROPARTE (SECONDARY LOCK IN CLOSED POSITION (AFTER CONTACTS INSERTION INTO CAVITIES) FOR MATING ONTO COUNTERPART)
- ACCOPIABILE CON DIMA IN ACCORDO ALLA SPEC. 114-18063-122 E CON CONNETTORE P/N 1-967079-3 (MATEABLE WITH INTERFACE ACCORDING TO SPEC. 114-18063-122 AND WITH PIN CONNECTOR P/N 1-967079-3)

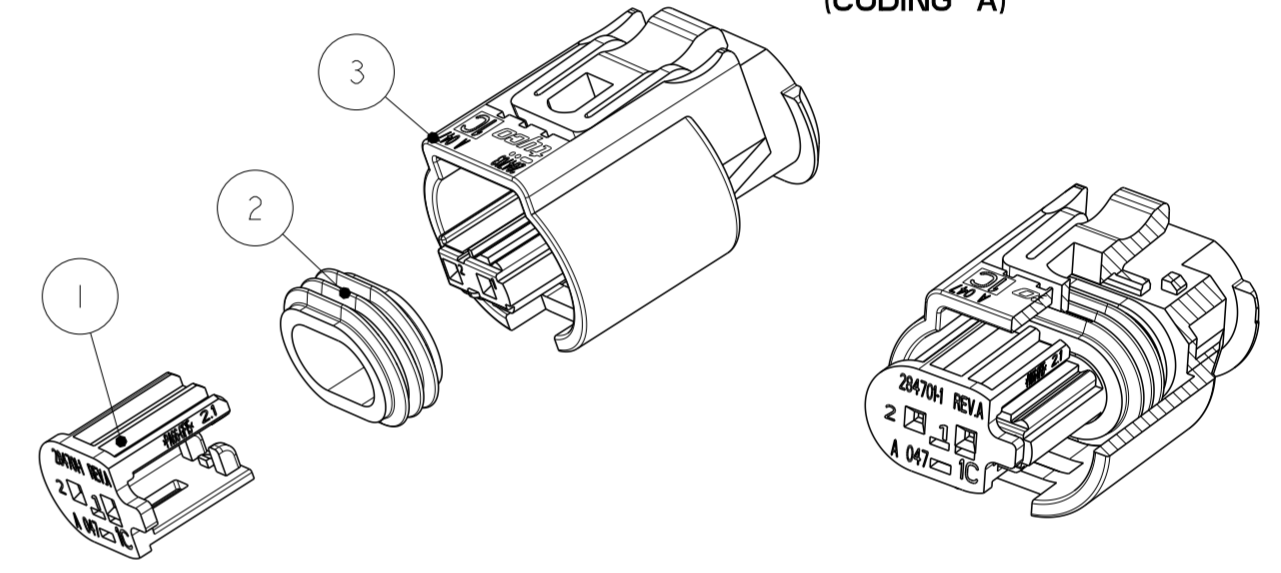

CODICI DI POLARIZZAZIONE / (POLARIZATION CODINGS)

Diagram	Part Number	Description
	P/N 284703-1	CODICE A / (CODING A) SECONDARY LOCK COLORE VERDE (SECONDARY LOCK GREEN COLOUR)
	P/N 284703-2	CODICE B / (CODING B) SECONDARY LOCK COLORE GRIGIO (SECONDARY LOCK GREY COLOUR)
	P/N 284703-3	CODICE C / (CODING C) SECONDARY LOCK COLORE BLU (SECONDARY LOCK BLUE COLOUR)

Q.TA' (Q.TY)	COLORE (COLOUR)	MATERIALE (MATERIAL)	DESCRIZIONE (DESCRIPTION)	NO. (ITEM)
1	NERO/(BLACK)	PA66 GF	BLOCCHETTO/(HOUSING)	3
1	TRASPARENTE/(TRANSPARENT)	LSR	GUARNIZIONE/(SEALING)	2
1	VED. TABELLA CODICI POLARIZ. (SEE POLARIZATION CODINGS TABLE)	PA66 GF	SECONDARY LOCK	1

THIS DRAWING IS A CONTROLLED DOCUMENT.

DIMENSIONS: mm

TOLERANCES UNLESS OTHERWISE SPECIFIED:

0 PLC	±0.3
1 PLC	±0.3
2 PLC	±0.3
3 PLC	±
4 PLC	±
ANGLES	±
FINISH	±

MATERIAL: SEE TABLE

Customer Drawing

APVD: A. PLAZIO, R. MARTINI, A. GENTA

PRODUCT SPEC: 108-20234

APPLICATION SPEC: 411-20066

WEIGHT: -

NAME: 2 POS. MQS SOCKET ASS'Y

SIZE: A2

CAGE CODE: 0779

DRAWING NO: C-284703

RESTRICTED TO: -

SCALE: 3:1

SHEET 1 OF 1

REV D2

单击下面可查看定价，库存，交付和生命周期等信息

[>>TE Connectivity\(泰科\)](#)