

LOC		DIST		REVISIONS			
P	LTR	DESCRIPTION	DATE	DWN	APVD		
N		REV PER ECO-15-016251	13NOV15	KG	CD		

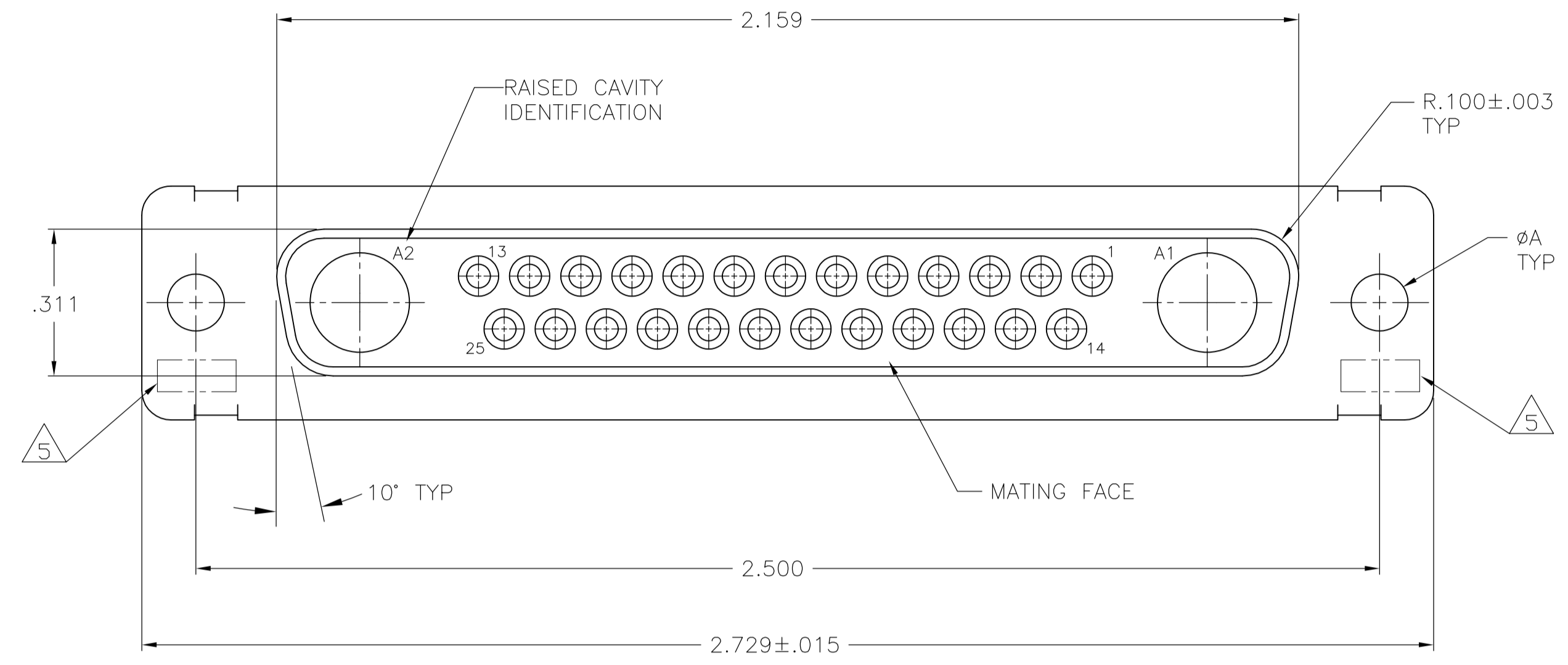

- THIS RECEPTACLE WILL MATE WITH ANY 27C2, SIZE 4 PLUG IN AMPLIMITE SERIES.
 - MAXIMUM WIRE INSULATION TO BE USED WITH THIS RECEPTACLE IS ϕ .068.
 - THIS CONNECTOR ACCEPTS (2) POWER 8, OR COAX SOCKET CONTACTS IN POSITIONS A1 THRU A2, PURCHASED SEPARATELY.
 - THIS CONNECTOR ACCEPTS SIZE 20 SOCKET SIGNAL CONTACTS IN POSITIONS 1 THRU 25, PURCHASED SEPARATELY.
- 5 UL/CSA DESIGNATION STAMPED IN THIS AREA, OPTIONAL.
 - 6 STEEL PER ASTM-A-109.
 - 7 BRASS PER MIL-C-50 AND ASTM-B-36 UNS NO. C26000.
 - 8 FINISH: CADMIUM PLATED PER QQ-P-416.
 - 9 GOLD PLATED PER MIL-G-45204 TYPE II, GRADE C, CLASS 1 OVER COPPER PER MIL-C-14550, CLASS IV.
 - 10 FINISH: TIN PER ASTM-B-545 .000400 MIN THK OVER COPPER PER AMS2418 .000050 MIN THK.
 - 11 FINISH: ZINC PLATE PER ASTM-B-633 .000200-.000400 THK WITH SUPPLEMENTARY CHROMATE (Cr3+).

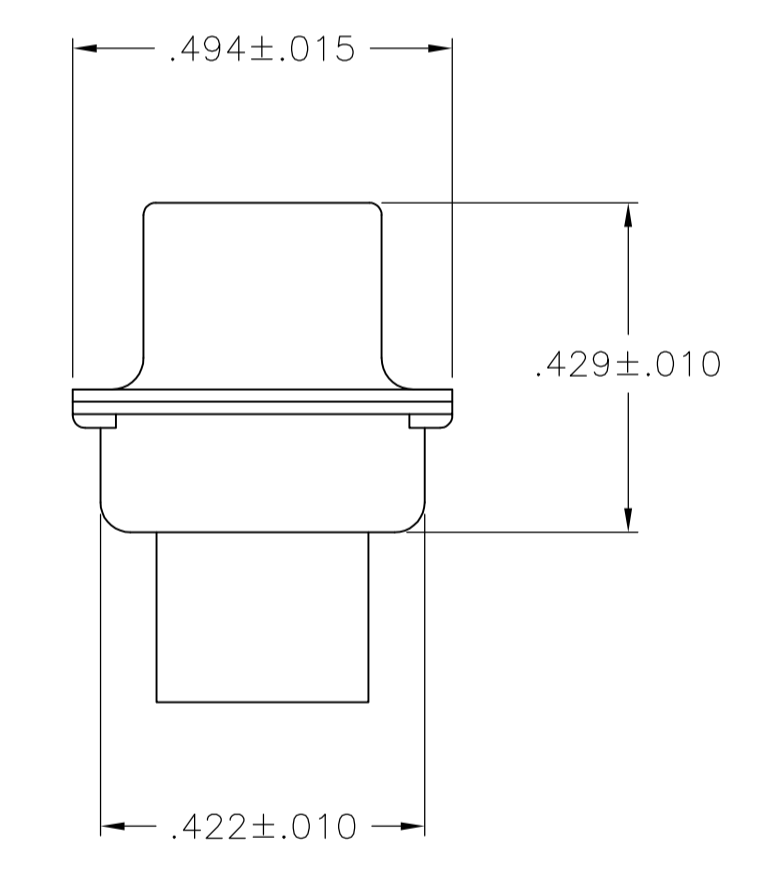
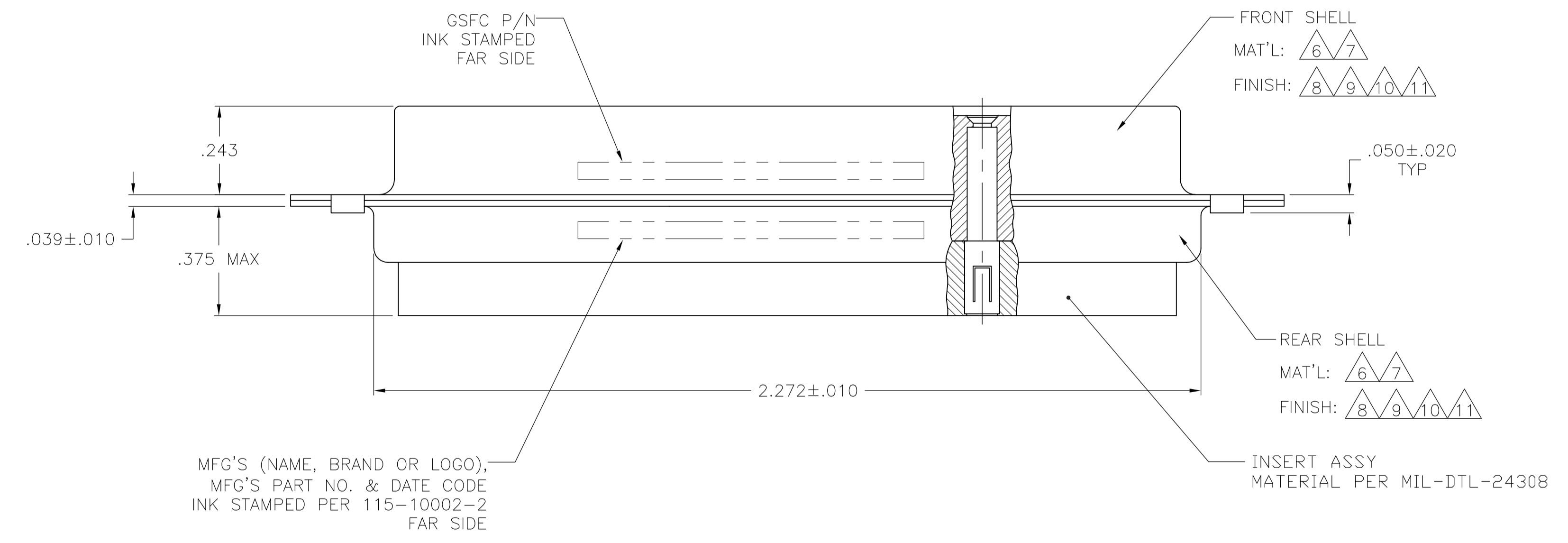

REMARKS	ØA	GSFC P/N	PART NO.
6 10	.120	-	5-212542-4
6 11	.120	-	5-212542-1
6 10	.120	-	212542-4
7 9	.154	311P405-21S-B-15	212542-3
7 9	.120	311P405-21S-B-12	212542-2
6 8	.120	-	212542-1

THIS DRAWING IS A CONTROLLED DOCUMENT.

DIMENSIONS: INCHES	TOLERANCES UNLESS OTHERWISE SPECIFIED:	DIN C.C.THOMAS 21JAN88	APVD A.FMADI 27JAN88	NAME
0 PLC ± -	1 PLC ± -	2 PLC ± -	3 PLC ± .005(0.13)	4 PLC ANGLES ± # 0°30'
MATERIAL	FINISH	WEIGHT	SCALE 4:1	SHEET 1 OF 1

RECEPTACLE ASSEMBLY
AMPLIMITE 27C2
SIZE 4, SERIES 109, COAX MIX

SIZE A1 CAGE CODE 00779 DRAWING NO. 212542

CUSTOMER DRAWING

单击下面可查看定价，库存，交付和生命周期等信息

[>>TE Connectivity\(泰科\)](#)