

THIS DRAWING IS UNPUBLISHED. RELEASED FOR PUBLICATION .19
 © COPYRIGHT 19 BY AMP INCORPORATED. ALL RIGHTS RESERVED.

LOC		DIST		REVISIONS			
P	LTR	DESCRIPTION	DATE	DWN	APVD		
AG	97						
C		ADD 1--4, PER NPR 99-6	09SEP99	LM	GR		

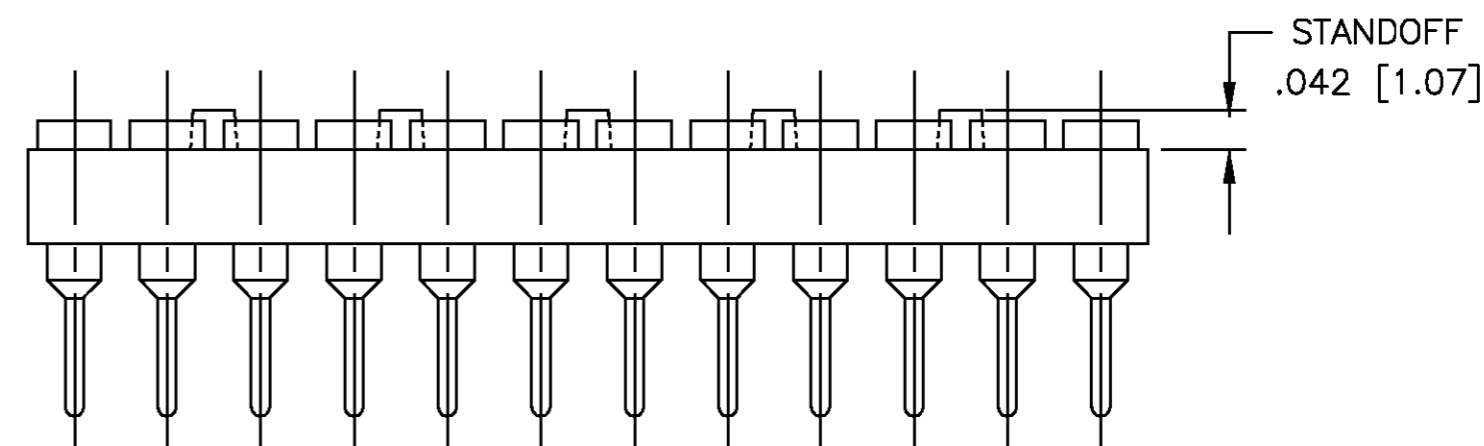
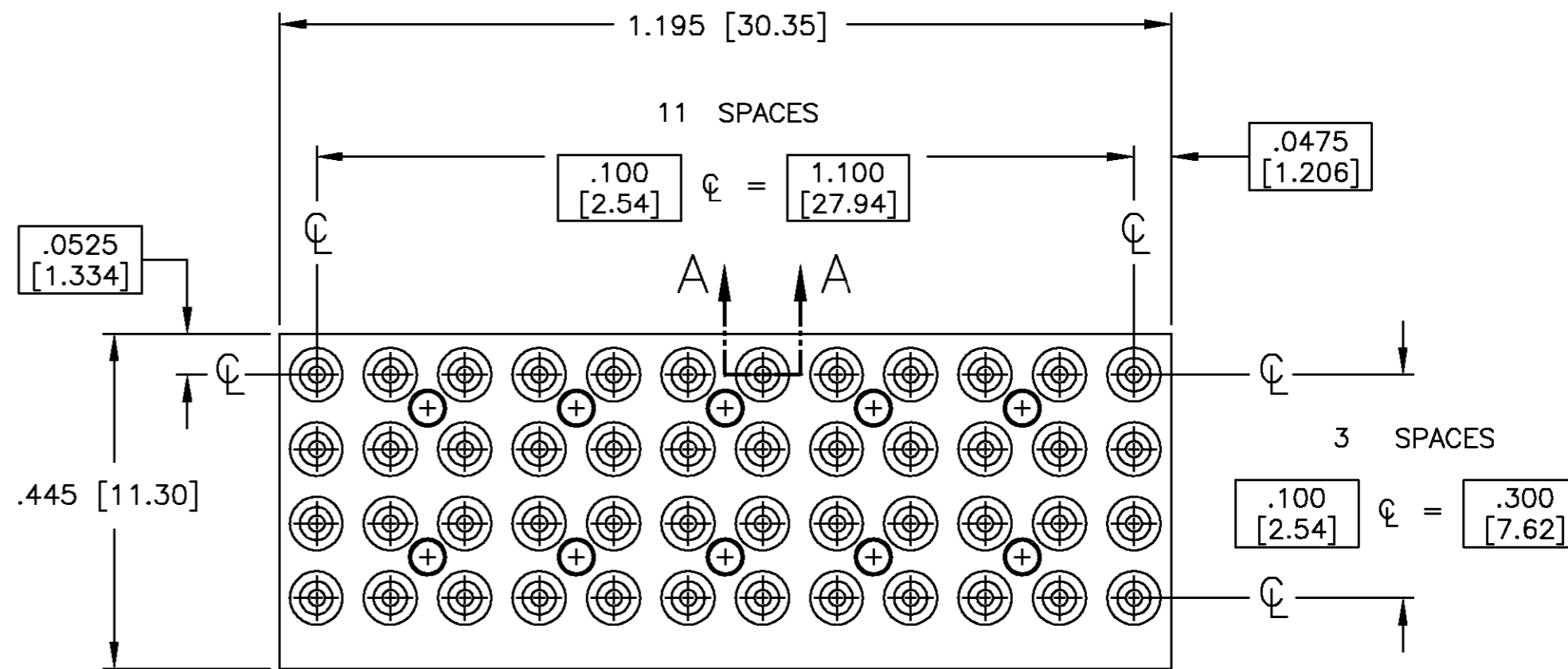
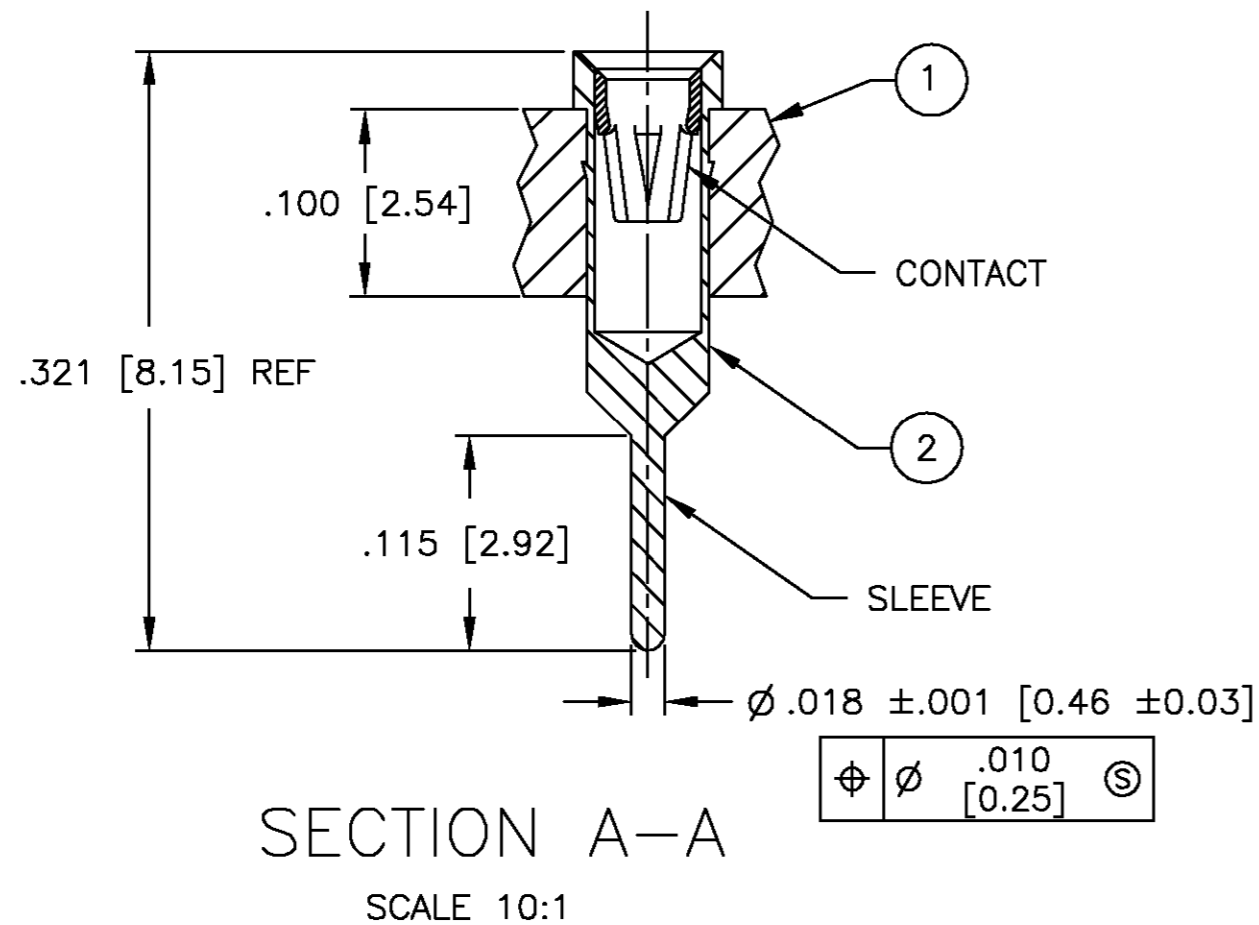

- TOLERANCE NON ACCUMULATIVE.
- SLEEVE ASSEMBLY FITS PCB HOLE SIZE: $.035 \pm .003 [0.89 \pm 0.08]$ DIA.
- CONTACT ACCEPTS $.025 [0.64]$ SQ OR $.030 \pm .003 [0.76 \pm 0.08]$ DIA ROUND LEAD.
- SLEEVE MATERIAL: BRASS CDA C36000.
- SLEEVE PLATING:
 - 5A .000005-.000015 [0.00013-0.00038] GOLD PER MIL-G-45204, TYPE II, GRADE C, OVER .000030-.000070 [0.00076-0.00178] DULL NICKEL PER QQ-N-290, CLASS 2 OVER .000010-.000040 [0.00025-0.00102] MATTE COPPER PER MIL-C-14550 OR
 - 5B .000150-.000250 [0.00381-0.00635] BRIGHT 93/7 TIN LEAD PER MIL-P-81728 OVER .000030-.000070 [0.00076-0.00178] DULL NICKEL PER QQ-N-290, CLASS 2 OVER .000010-.000040 [0.00025-0.00102] MATTE COPPER PER MIL-C-14550.
- CONTACT MATERIAL: BERYLLIUM COPPER CDA C17200.
- CONTACT PLATING:
 - 7A .000030 [0.00076] MIN GOLD PER MIL-G-45204, TYPE II, GRADE C OVER .000030-.000070 [0.00076-0.00178] DULL NICKEL PER QQ-N-290, CLASS 2 ON HEAT TREATED CONTACT PER MIL-H-7199A OR
 - 7B .000010 [0.00025] MIN GOLD PER MIL-G-45204, TYPE II, GRADE C OVER .000030-.000070 [0.00076-0.00178] DULL NICKEL PER QQ-N-290, CLASS 2 ON HEAT TREATED CONTACT PER MIL-H-7199A OR
 - 7C .000100-.000200 [0.00254-0.00508] BRIGHT 93/7 TIN LEAD PER MIL-P-81728 OVER .000010-.000040 [0.00025-0.00102] MATTE COPPER PER MIL-C-14550, ON HEAT TREATED CONTACT PER MIL-H-7199A OR
 - 7D .000300-.000400 [0.00762-0.01016] BRIGHT 60/40 TIN LEAD PER MIL-P-81728 OVER .000050-.000100 [0.00127-0.00254] DULL NICKEL PER QQ-N-290, CLASS 2 OVER .000010-.000040 [0.00025-0.00102] MATTE COPPER PER MIL-C-14550.
- CONTACT RATING: 3 A MAX VDC.
CONTACT RESISTANCE: 15 mOHM MAX (100 ma AND 50 mV MAX).
- INSULATION RESISTANCE: 5000 MEGO MIN MEASURED FROM PIN TO PIN AT 500 V DC.
- OPERATING TEMPERATURE: GOLD PLATED CONTACT -55°C TO +125°C
TIN PLATED CONTACT -40°C TO +105°C.

- CARRIER MATERIAL:
 - 11A THERMOPLASTIC POLYESTER (PBT) RATED 94V-0 BLACK COLOR.
 - 11B BROWN GLASS FILLED (PBT)

12. VALUES IN BRACKETS ARE METRIC EQUIVALENTS.

PRELIMINARY	5B/7C	TIN LEAD/TIN LEAD	544844-2	11B	4-544651-6	1-545092-4
	5B/7C	TIN LEAD/TIN LEAD	544844-1	11A	4-544651-6	545092-4
		PLATING	1 CARRIER NO		2 SLEEVE ASSY NO	PART NO.
			QTY = 1		QTY = 48	

THIS DRAWING IS A CONTROLLED DOCUMENT.		DWN	RS	10/11/93	AMP AMP Incorporated Harrisburg Pa 17105-3608
DIMENSIONS: INCHES		CHK	RLM	9-15-94	
TOLERANCES UNLESS OTHERWISE SPECIFIED:		APVD	DJS	9-15-94	
0 PLC ± -		PRODUCT SPEC		NAME	
1 PLC ± -		APPLICATION SPEC		PGA SOCKET	
2 PLC ± -		WEIGHT		SIZE	
3 PLC ± .005 [0.13]		CUSTOMER DRAWING		CAGE CODE	
4 PLC ± -		SCALE		DRAWING NO	
ANGLES ± 0°30'		SHEET		RESTRICTED TO	
FINISH		1 OF 1		REV	
MATERIAL NOTED		5:1		C	

单击下面可查看定价，库存，交付和生命周期等信息

[>>TE Connectivity\(泰科\)](#)