

4

3

2

1

THIS DRAWING IS UNPUBLISHED. RELEASED FOR PUBLICATION  
 © COPYRIGHT - By - ALL RIGHTS RESERVED.

REVISIONS			TM		
P	LTR	DESCRIPTION	DATE	DWN	APVD
E1		REVISED PER ECO-16-008890	15JUN2016	NK	DR
E2		REVISED PER ECO-17-008114	01JUN2018	RS	DR

<b>AMP</b> WIRE RANGE	LISTED	LR7189 CERTIFIED
16-14 AWG SOLID OR STRANDED	16-14 AWG SOLID OR STRANDED	16-14 AWG SOLID OR STRANDED

- 1 STAMP AMP 16-14\*, 2½-4 APPROX AS SHOWN
- 2 WIRE INSULATION DIA: 2.921-4.318[.115-.170]
- 3 BODY MATERIAL THK: 0.787±0.051[.031±.002]
- 4 APPLIES FROM EDGE OF METAL WIRE BARREL TO THE CENTER OF THE STUD HOLE

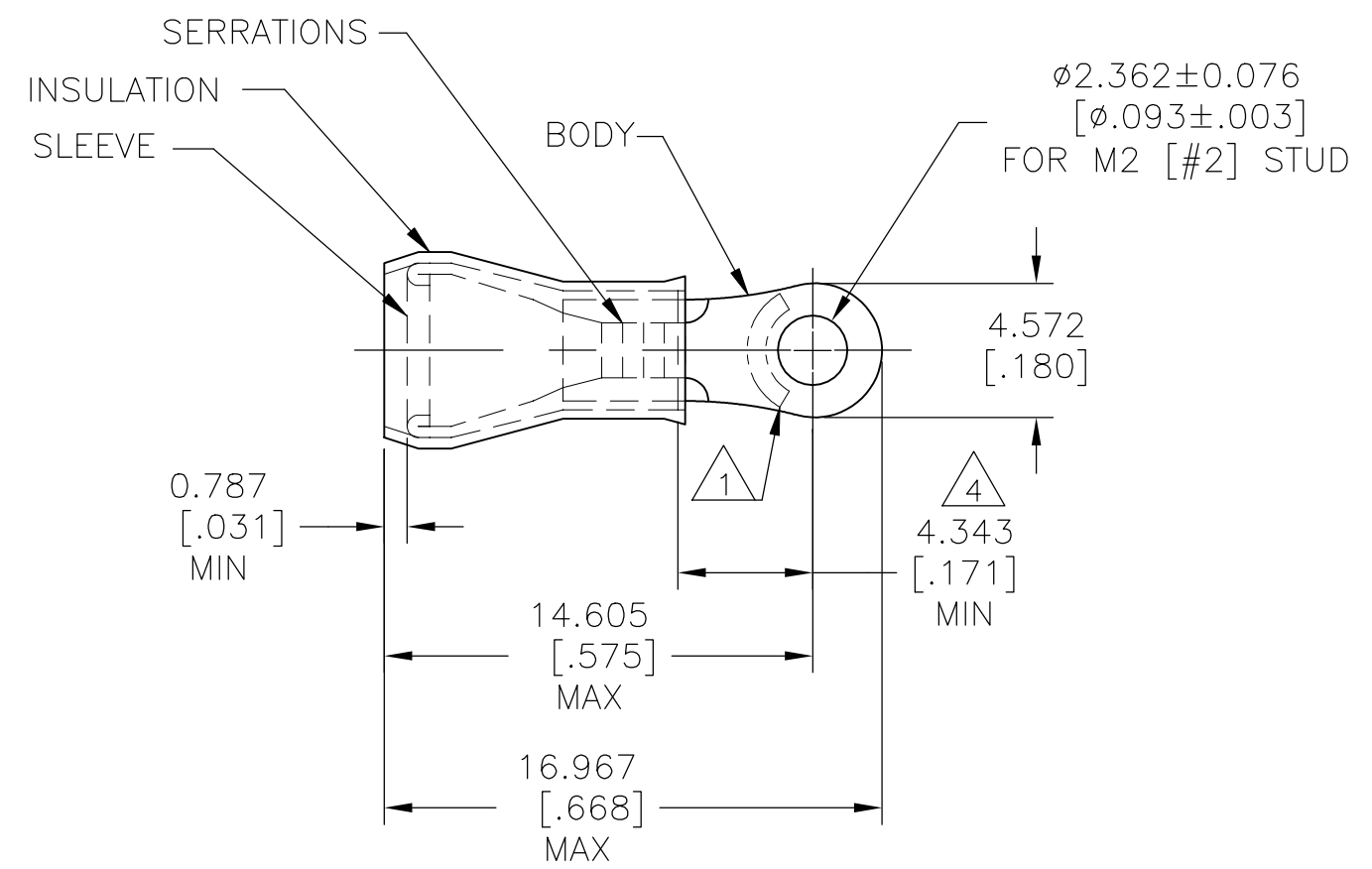

1000	LOOSE PIECE	324993
QUANTITY	PACKAGE TYPE	PART NO

<b>AMP INCORPORATED</b> CUSTOMER SERVICE SYSTEMS			THIS DRAWING IS A CONTROLLED DOCUMENT.		DWN DK SCHRUM 10/9/92	TE Connectivity Ltd.				
FOR ADDITIONAL PRODUCT INFORMATION OR COPIES OF DRAWINGS AND TECHNICAL DOCUMENTS	PRODUCT INFORMATION CENTER 1-800-522-6752	MAX RECOMMENDED OPERATING TEMPERATURE: 105° C [221°F] MAX	DIMENSIONS: mm [INCHES]		CHK ML ELLIS 10/12/92	NAME TERMINAL, RING TONGUE, PIDG™ WIRE SIZE, 16-14 AWG				
	FOR APPLICATION TOOLING INFORMATION	CUSTOMER SERVICE HOTLINE 1-800-722-1111			VOLTAGE RATING: 300 V MAX				APVD M BARNABA 10/12/92	
FOR ORDER ENTRY	1-800-526-5142	CIRCULAR MIL AREA: 1.04-2.62mm² [2,050-5,180] SOLID OR STRANDED	MATERIAL COPPER ASTM B-152 SLEEVE, BLUE NYLON	FINISH TIN PLATE PER ASTM B545	PRODUCT SPEC UL 486A	APPLICATION SPEC 114-2157	SIZE A3	CAGE CODE 00779	DRAWING NO C-324993	RESTRICTED TO -
					CUSTOMER DRAWING		SCALE 4:1	SHEET 1 OF 1	REV E2	

单击下面可查看定价，库存，交付和生命周期等信息

[>>TE Connectivity\(泰科\)](#)