

THIS DRAWING IS UNPUBLISHED. RELEASED FOR PUBLICATION  
 © COPYRIGHT BY TYCO ELECTRONICS CORPORATION. ALL INTERNATIONAL RIGHTS RESERVED.

| LOC | DIST | REVISIONS   |                           |         |          |
|-----|------|-------------|---------------------------|---------|----------|
| P   | LTR  | DESCRIPTION | DATE                      | DWN     | APVD     |
| G   | 14   | T           | REVISED PER ECR-10-003079 | 03MAR10 | JR<br>TM |

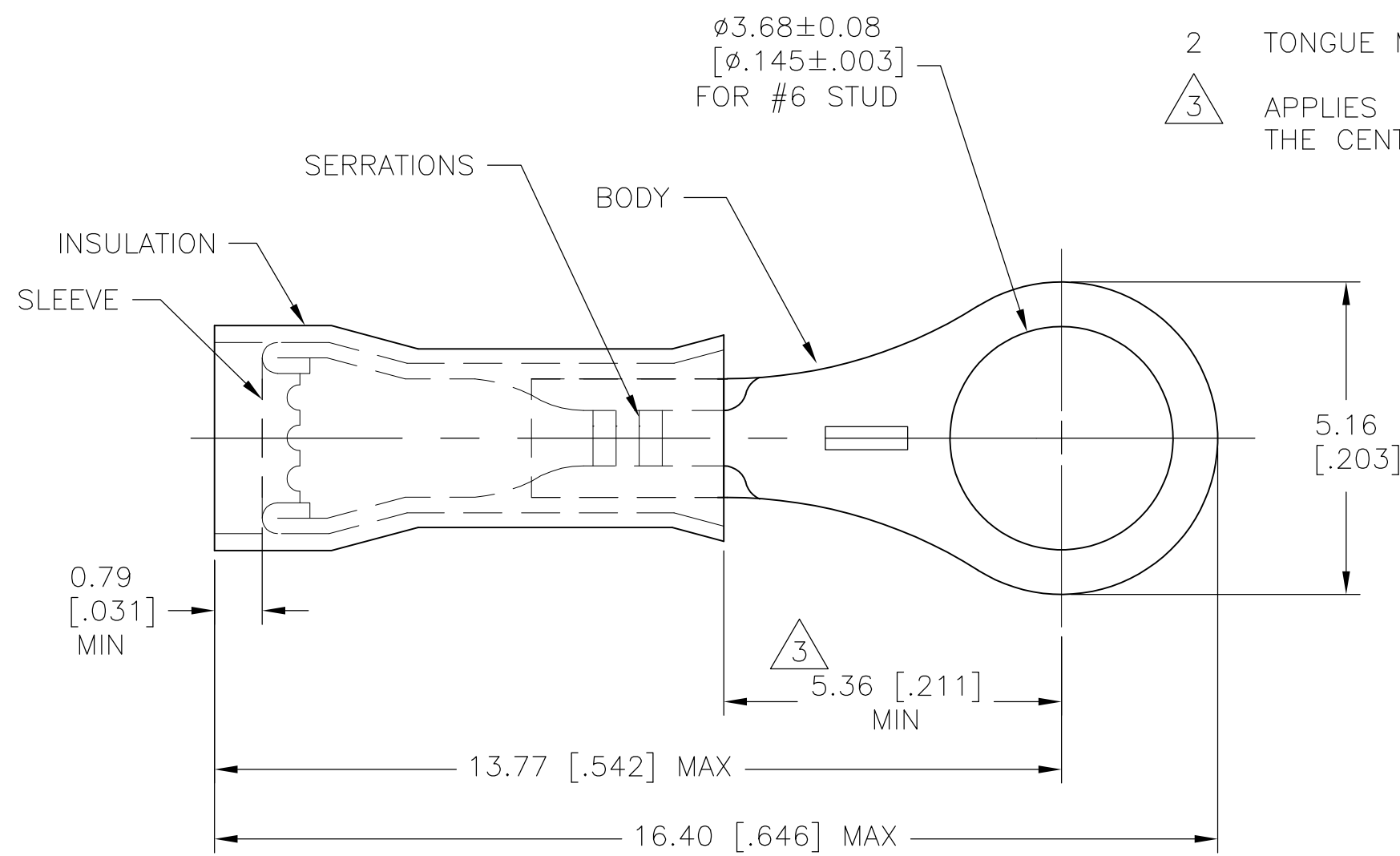

- 1 FOR 1.27 [.050] TO 2.08 [.082] WIRE INSULATION DIA
- 2 TONGUE MATERIAL THK =  $0.46 \pm 0.05$  [.018 ± .002]
- 3 APPLIES FROM THE METAL EDGE OF THE BARREL TO THE CENTER OF THE STUD

| QTY  | DESCRIPTION    | MATERIAL & FINISH  | PART NO                           |
|------|----------------|--|-----------------------------------|
| 5000 | 321019 ON TAPE | BODY & SLEEVE:<br>COPPER (ASTM-B152)<br>TIN PL (ASTM-B545) | OBSOLETE<br><del>2-321019-3</del> |
| 1000 | WIRE TERMINAL  | INSULATION: YELLOW , PVC                                   | 321019                            |

|  |  |                             |   |                    |
|--|--|-----------------------------|---|--------------------|
| THIS DRAWING IS A CONTROLLED DOCUMENT.   |  | DWN<br>JR RUTH<br>03MAR10   | Tyco Electronics Corporation<br>Harrisburg, PA 17105-3608 |                    |
| DIMENSIONS:<br>mm [INCHES]   |  | CHK<br>JEFF RUTH<br>03MAR10 | NAME<br>TOM MICHIELUTTI                                   |                    |
| TOLERANCES UNLESS OTHERWISE SPECIFIED:   |  | APVD<br>03MAR10             | PRODUCT SPEC  |                    |
| 0 PLC ± -<br>1 PLC ± -<br>2 PLC ± -<br>3 PLC ± 0.20 [.008]<br>4 PLC ± -<br>ANGLES ± 5° |  | APPLICATION SPEC            |   |                    |
| MATERIAL<br>SEE TABLE  |  | WEIGHT<br>-                 | SIZE<br>A3  | CAGE CODE<br>00779 |
| FINISH<br>SEE TABLE  |  | DRAWING NO<br>G-321019      |   | RESTRICTED TO<br>- |
| CUSTOMER DRAWING   |  |                             | SCALE<br>10:1   | SHEET<br>1 OF 1    |
|  |  |                             | REV<br>T  |                    |

单击下面可查看定价，库存，交付和生命周期等信息

[>>TE Connectivity\(泰科\)](#)