

11 MOUNTED COVER OPTIONS
 Befestigungsmoeglichkeiten der Kappe

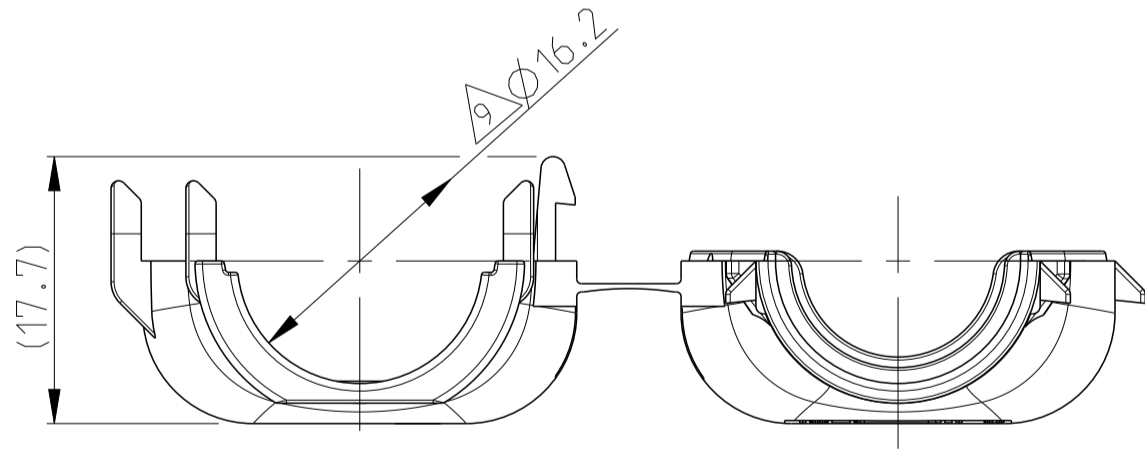

TE LOGO RELATED TO MOLDING TOOL
 TE Logo abhaengig von Spritzgusswerkzeug

G2

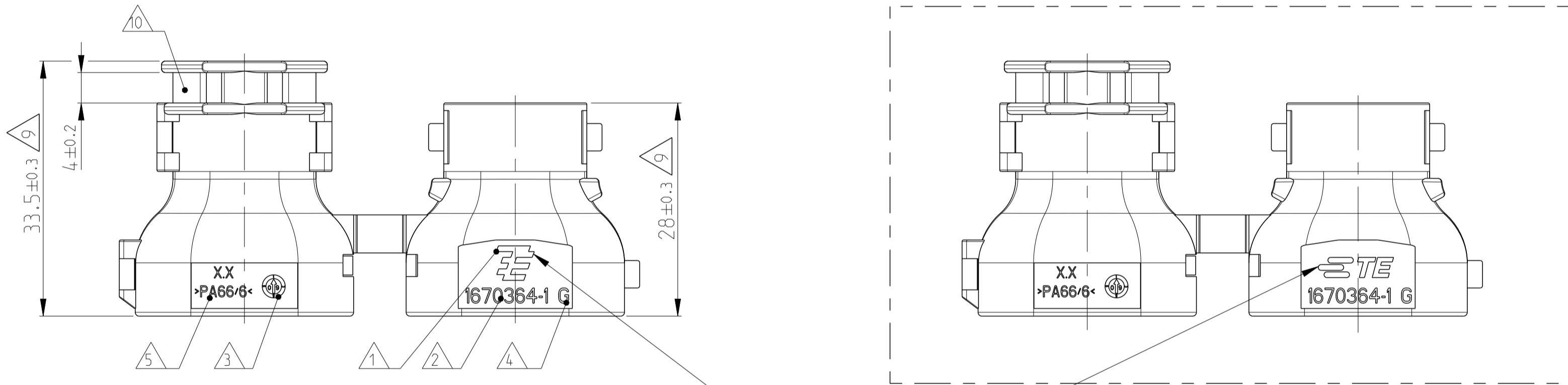
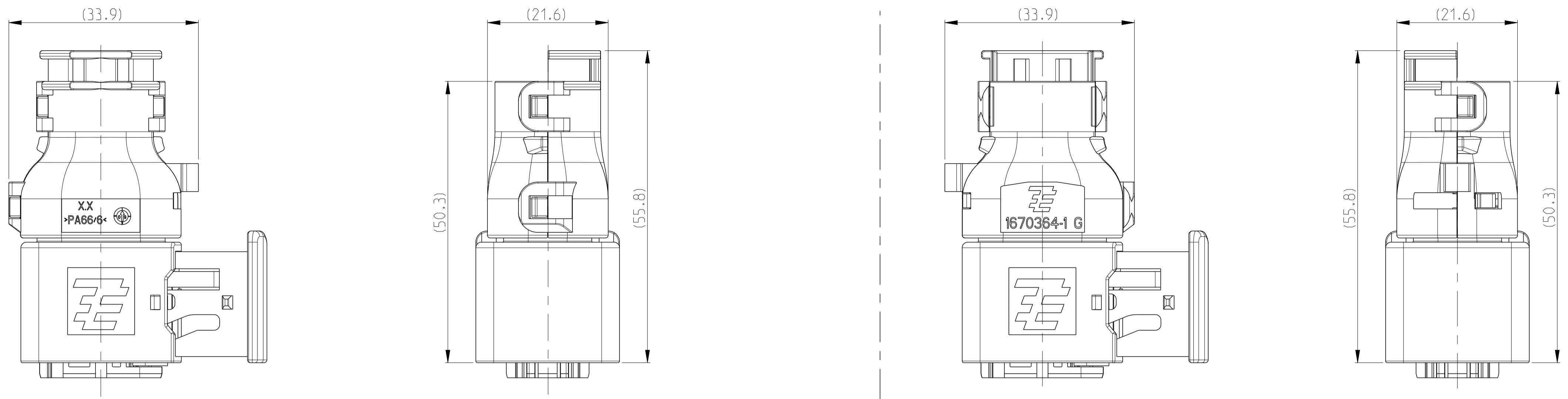
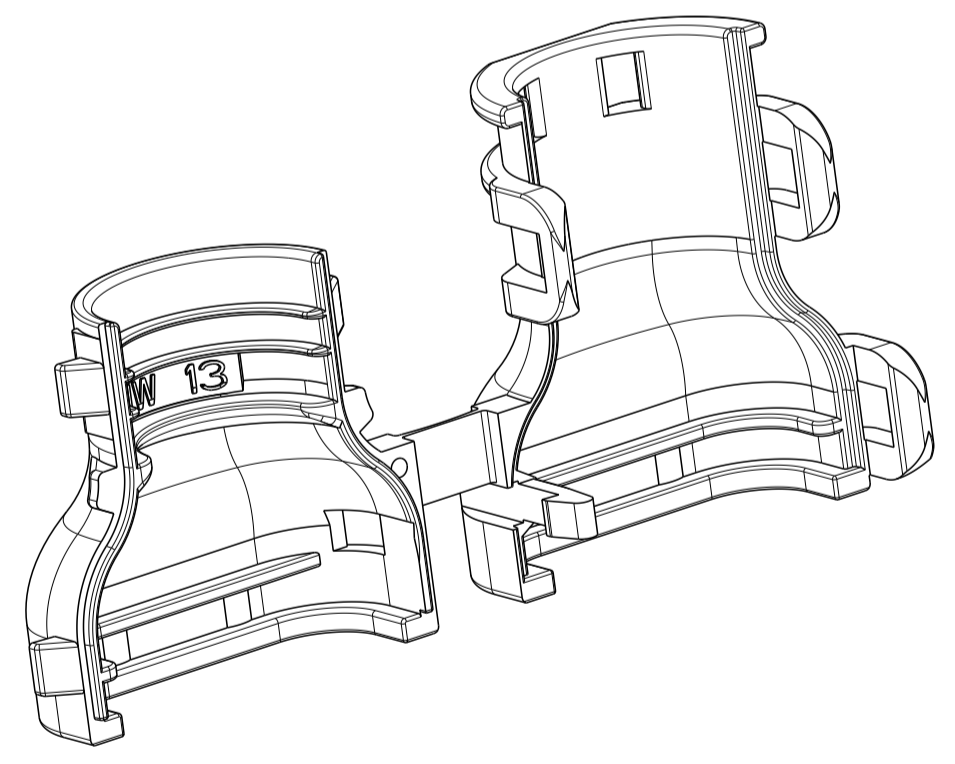
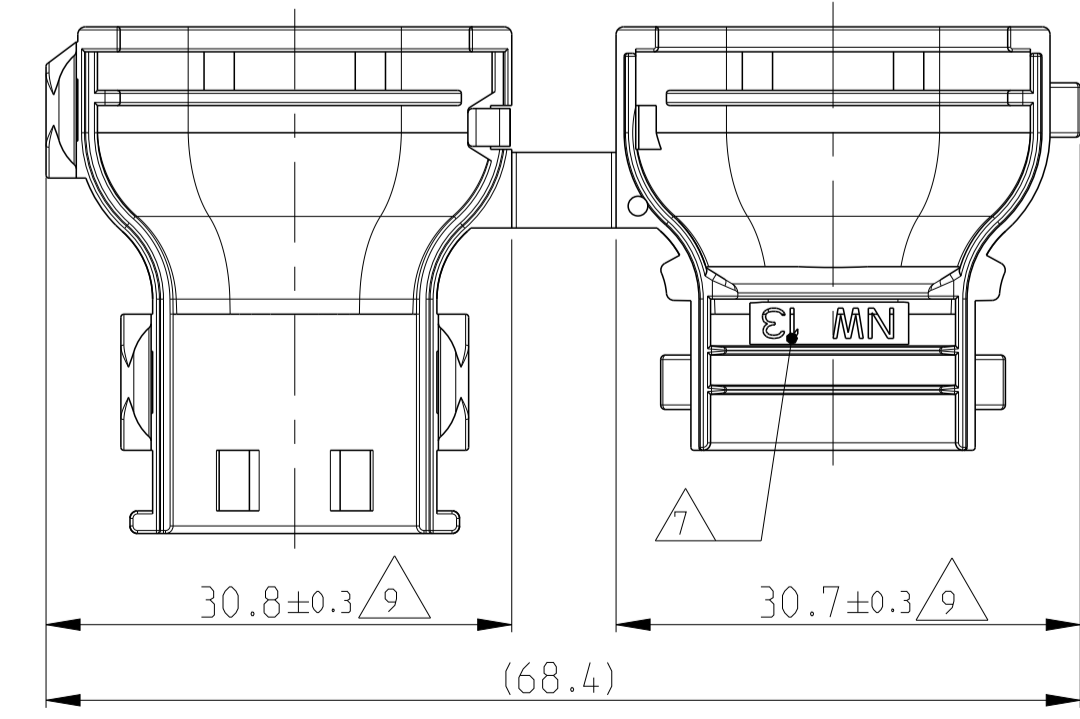

PROJECT NO. SEE NOTE 11		REVISIONS			
P	LTN	DESCRIPTION	DATE	DWN	APVD
G		ECR-09-012157 (PCN E-09-005080 FOR PART CHANGE)	04NOV2009	SJ	CE
G1		DETAILS SEE PCN E-10-002668	04FEB2010	SJ	JG
G2		DETAILS SEE PCN E-16-011236	15AUG2016	MAH	GILC

NOTES
 Bemerkungen

- 1 TE LOGO
TE Logo
- 2 TE ORDER-NO.
TE Bestell-Nr.
- 3 PRODUCTION DATE
Produktionsdatum
- 4 LETTER-INSERT FOR THE REVISION STATUS OF THE MOULD
Schriftsatz fuer Aenderungszustand des Werkzeuges
ACTUAL STATUS: SEE TABLE
Aktueller Stand: siehe Tabelle
- 5 MATERIAL MARKING ACCORDING TO VDA 260
Werkstoffkennzeichnung nach VDA 260
- 6 BULK PACKAGING IN CORRUGATED BOX
Schuetftgut im Versandkarton
- 7 CABLE EXIT DESIGNED FOR CORRUGATED TUBE NW 13
Kabelabgang ausgelegt fuer Wellrohr NW 13
- 8 MALFUNCTION CAUSED BY LAQUER IS NOT COVERED
BY TE WARRANTY
Funktionsbeeintraechtigung durch Lackieren liegt nicht
im Einfluss und Gewaehrleistungsumfang von TE
- 9 WARPAGE UP TO -1.0mm FROM NOM. DIMENSION PERMITTED
Verzug zulaessig bis -1.0mm vom Nennmass
- 10 MAX. CABLE TIE WIDTH: 3.8mm
max. Kabelbinderbreite: 3.8mm
- 11 SUITABLE FOR TAB AND RECEPTACLE HOUSING GROUP C
SEE PRODUCT GROUP DRAWING 1563709
Passend fuer Flachstecker- und Buchsengehause der Gruppe C
siehe Produktgruppenzeichnung 1563709

THIS DRAWING IS A CONTROLLED DOCUMENT.		DWN D. Bischoff	26OCT2006	STE TE Connectivity
DIMENSIONS: mm		CHK J. Grandzow	31OCT2006	
TOLERANCES UNLESS OTHERWISE SPECIFIED:		APVD C. Oberwein	02NOV2006	NAME COVER, 180 Kappe, 180 Grad HDSCS - GROUP C
MATERIAL PA66/6 (V-0)		ISO 8015	108-94.020	
FINISH BLACK schwarz		ISO 1501-140	116-18756	SIZE A1
WEIGHT 5.6g		APPLICATION SPEC	116-18756	CAGE CODE 00779
CUSTOMER DRAWING		RESTRICTED TO		SCALE 5:1
SHEET 1 OF 1		REV. G2		

0-1670364-1	G	COVER, 180° Kappe, 180°	1
TE ORDER-NO. TE Bestell-Nr.	REV.	DESCRIPTION Beschreibung	ITEM

单击下面可查看定价，库存，交付和生命周期等信息

[>>TE Connectivity\(泰科\)](#)